

Manual

for Operation



EFT 500

EFT/burst generator pulse 5/50ns

EFT500 – an EFT/Burst generator – is an intelligent solution offering exactly what you need for full-compliance immunity tests against Electrical/Fast transients phenomena. The distinct operation features, convenient DUT connection facilities, a clearly arranged menu structure and display philosophy as well as the pre-programmed standard test routines make testing easy, reliable and safe.

Extendable by a variety of test accessories the EFT 500 is a universal equipment for a broad range of recommendations even for three-phase applications up to 100A

- IEC 61000-4-4
- IEC 61000-4-4 Ed 2
- EN 61000-4-4
- EN 61000-4-4 Ed 2

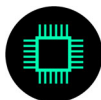

Contents

1.	Operating Functions	3
1.1.	Front view.....	3
1.2.	Rear view	4
2.	Operation.....	5
2.1.	Description of the menus	5
2.2.	Main Menu	5
2.3.	Quick Start	6
2.4.	User Test Routines	7
2.5.	Test Routine as per IEC 61000-4-4 (2004-07) Ed 2	9
2.6.	Service	9
2.7.	Setup.....	10
3.	Test Equipment EFT 500.....	11
3.1.	Specification of the test parameters	11
3.2.	Burst generation.....	11
3.3.	Coupling decoupling network.....	12
3.3.1.	Coupling/decoupling network for ac/dc power lines	12
3.3.2.	Capacitive coupling clamp	12
3.4.	Burst Test Setup	13
3.5.	Computer setup for EFT/Burst testing.	14
4.	Technical data	16
4.1.	EFT Electrical Fast Transients Burst as per IEC 61000-4-4.....	16
5.	Maintenance.....	17
5.1.	General	17
5.2.	Test set-up	17
5.3.	Calibration and verification.....	17
6.	Delivery Groups.....	18
6.1.	Basic equipment	18
6.2.	Accessories and options	18
7.	Appendix	19
7.1.	Declaration of CE-Conformity	19
7.2.	EFT 500 - General Diagram.....	20
7.3.	EFT 500 - Overview	20
7.4.	EFT 500 Menu overview	21

1. Operating Functions

1.1. Front view

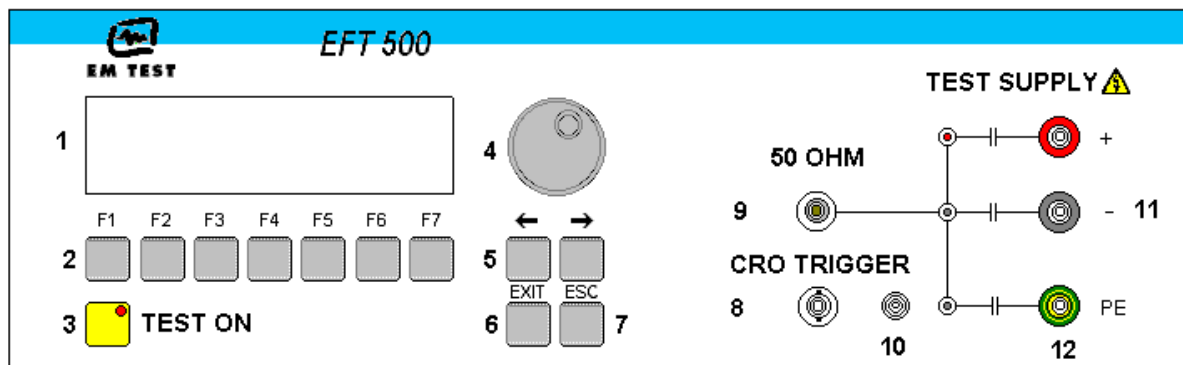

- | | | | |
|---|-------------------------|----|------------------------|
| 1 | Display | 7 | Escape |
| 2 | "Test On" | 8 | CRO |
| 3 | Function keys "F1..F7" | 9 | HV pulse output 50 ohm |
| 4 | Knob (Inc / Dec) | 10 | Ground reference |
| 5 | Cursor keys "←" and "→" | 11 | Coupling "On" |
| 6 | Exit | 12 | EUT test supply |

1 Display

All functions and parameters are displayed (8 lines with max. 40 characters).

2 Test On

By pressing the key "Test On" the test procedure is initiated with the preselected parameters. The red LED indicates the trigger of a burst event.

3 Function keys "F1 .. F7"

Parameters and functions, displayed in the lowest line, can be selected with the related function key.

4 Knob (Inc / Dec)

The knob increments or decrements test parameters with a numeric value or selects from a list of parameters.

5 Cursor keys

Parameters and functions can be changed on-line. The selection of these parameters is realized with the cursor moving to the left or to the right.

6 Exit

Pressing of the Exit function will cause a reset of the firmware. This is only possible if no test routine is running.

7 ESC

When pressing the ESC button the user moves back one page in the menu.

8 BNC - CRO Trigger

At the BNC output the generator trigger can be checked, e.g. the burst duration, the burst repetition rate and the spike frequency (+15 V rectangular). This output signal can also be used to trigger external measuring devices (e.g. an oscilloscope)

9 HV pulse output 50 ohm

External coupling devices such as the capacitive coupling clamp and the coupling network CNE 503 are connected to the coaxial 50 ohm output. Also the pulse parameters, on 50Ω and 1000Ω load condition, must be verified at this coaxial output.

10 Ground reference

During test or calibration procedure the burst generator must be grounded to the reference ground plane.

11 Coupling

The LED indicates that the pulses are coupled to the L –N –PE line.

12 EUT test supply

The coupling / decoupling network is part of the generator. The EUT is powered via the safety laboratory plugs at the front panel of the simulator. The nominal power mains supply is 250V/16A. For higher currents, up to 100A, the external coupling network CNE 503 shall be used.

1.2. Rear view

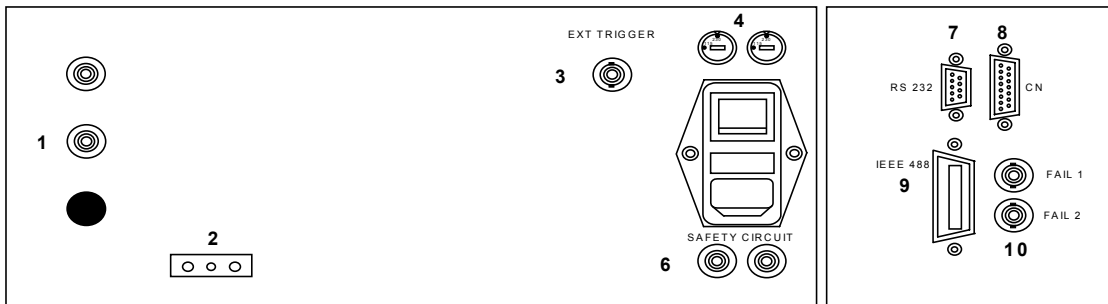

- | | |
|-------------------------------------|---|
| 1 DUT test supply input | 6 Safety circuit |
| 2 Reference earth connection | 7 Serial interface RS 232 |
| 3 External trigger | 8 Remote control connector CN |
| 4 Mains selector 115V / 230V | 9 Parallel interface GPIB / IEEE 488 |
| 5 Power on switch | 10 Fail input Fail 1 and Fail 2 |

1 DUT test supply input

The power supply for the EUT is connected to the safety laboratory connectors + and -. The front panel output is decoupled by the internal coupling/ decoupling network.

2 Reference ground connection

The generator has to be connected to the reference ground plane of the test set up. Very important is the connection at the front panel of the simulator.

3 External trigger

One single burst event can be released. Trigger level 5-15V positive going.

4 Mains selector

Selection of 115V / 230V

5 Power on switch

The switch is part of the mains filter. Mains fuses are part of the filter. (230V / 1A and 115V / 2A)

6 Safety circuit

To connect an external security circuit.

7 Serial interface

RS 232 interface with a 9-pole connector.

8 Remote control connector CN

To connect to the external coupling matrix CNE 503. All functions are controlled by the EFT 500. It is recommended to connect and power the CNE 503 before turning the power mains ON at the EFT 500.

9 Parallel interface GPIB / IEEE 488

IEEE 488 interface with IEEE connector.

10 Fail detection FAIL 1 (TEST STOP)

The BNC input FAIL 1 can be used for DUT monitoring. In case of a low going signal (to chassis ground) the EFT 500 will stop pulse generation and the actual running test routine is paused. The test routine than can be stopped completely or can be continued from break point.

A message of FAIL 1 is indicated in the LCD display as well as in the ISM ISO software.

10 Fail detection FAIL 2 (TEST PAUSE)

The BNC input FAIL 2 can be used for DUT monitoring. In case of a low going signal (to chassis ground) the EFT 500 will stop pulse generation and the actual running test routine is paused as long as the low level signal is available at the FAIL 2 input.

The test routine continues automatically as soon as the low level signal goes to high level.

A message of FAIL 2 is indicated in the LCD display as well as in the ISM ISO software.

2. Operation

2.1. Description of the menus

The simulator is operated by an easy menu control system. Seven function keys are available to select parameters and functions.

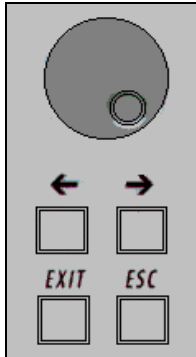

The selected parameter is blinking and can be changed by turning the knob (incr./decr.). The digit to be changed can be selected with the cursor (←→).

ESC will take you back to the previous level in the menu and set the displayed values. The latest settings are stored automatically and will be recalled when the menu is selected again.

EXIT will reset the firmware to the main screen.

All functions are indicated on the display; max. 8 lines and 40 characters.

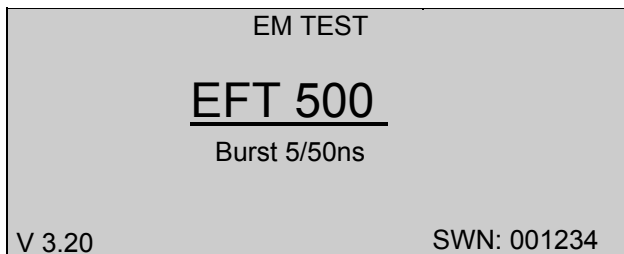

Start-up display example EFT 500

The serial number and the version number SWN are used for traceability reasons. These numbers are listed in the test reports and calibration certificates. These numbers also are listed within the test reports generated by the ISM ISO software

2.2. Main Menu

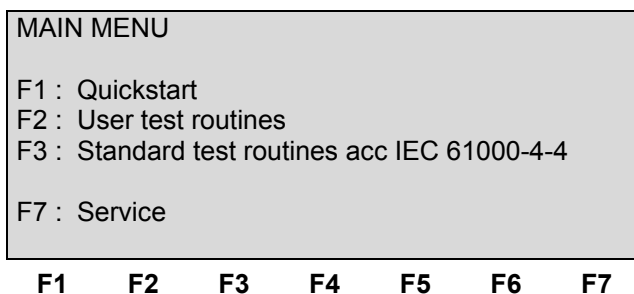

Quick Start

Easy and fast operation of the equipment without special functions. All parameters can be adjusted during the running test.

User Test Routines

The user can program, save and recall his own specific test routines. He can select standard routines or special functions such as automatic change of voltage or frequency during a test routine.

Test Routines as per IEC 61000-4-4

The user can call up the standard routines as per IEC 61000-4-4 and start them immediately.

Service

Set-up menu of the generator.

2.3. Quick Start

Easy and very fast operation of all standard functions of the equipment. The latest simulator settings are stored automatically and will be recalled when Quick Start is next selected.

QUICK START						
V	=	2000V	f	=	5.0kHz	
td	=	15.0ms	tr	=	300ms	
kop	=	L N PE	+/-	=	+	
T	=	5:00min				
START CHANGE			PRINT			
F1	F2	F3	F4	F5	F6	F7

Press **CHANGE** and the test parameters parameter can be changed.

Select the desired parameter with the related function key and change the value by turning the front panel knob. The cursor allows the user to define the digit to be changed (fast or slow change).

Press **START** and the test starts immediately with the displayed test parameters.

The operator now can navigate with the **Cursor** from parameter to parameter. The blinking parameter can be changed by turning the front panel knob.

Press **ESC** will bring the user back to the previous menu level.

Page 3 (Change)

QUICKSTART						
Voltage	V	:	200V	-	4400V	
Frequency	f	:	0.1kHz	-	1000.0kHz	
Duration	td	:	0.1ms	-	999.9ms	
Repetition	tr	:	10ms	-	9999ms	
Test time	T	:	0:01min	-	99:59min	
U	f	td	tr	kop	+/-	T
200	5.0	15.0	300	L N PE	+	5:00
F1	F2	F3	F4	F5	F6	F7

After starting the test the elapsed testtime is displayed. All function keys except F2 (manual trigger) can **Stop** the test routine. After test stop (Stop, Test OFF), the display keeps for about 2s.

Burst Spezifikation gemäss IEC 61000-4-4 (2004-07) Ed 2

f	=	5kHz	100kHz
tr	=	15ms	0.75ms
td	=	300ms	300ms

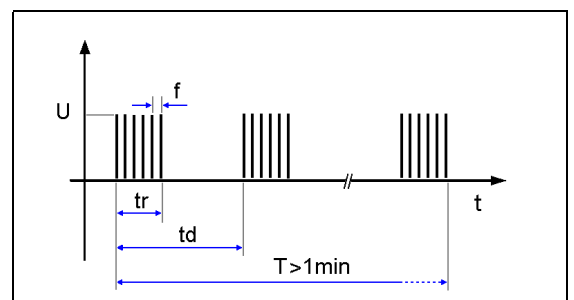

2.4. User Test Routines

The user can program, save and recall his own specific test routines. The next pages shows the selection of the functions.

USER TEST ROUTINES							Page 1 / 2
F1 : Customized test routines							
F2 : Voltage change after T by ΔV							
F3 : Frequency change after T by Δf							
F4 : Frequency sweep in one single burst							
Page 2							
F1	F2	F3	F4	F5	F6	F7	

USER TEST ROUTINES							Page 2 / 2
F1 : Change duration after T by Δdt							
F2 : Change polarity after T							
F3 : Random burst release							
F4 : Synchronized at fixed angle							
Page 1							
F1	F2	F3	F4	F5	F6	F7	

Each of these special functions can include 7 stored test routines.

CUSTOMISED TEST ROUTINES						
F1 : Store F1			F5 : Store F5			
F2 : Store F2			F6 : Store F6			
F3 : Store F3			F7 : Store F7			
F4 : Store F4						
F1	F2	F3	F4	F5	F6	F7

After selection of a stored test file the test parameters will be indicated on the display.

Customized test routines

The software controls standard test routines according to the specification of the user. All limitations are the same as defined under Quick Start.

Voltage change after T by ΔV

The test voltage is increased from V_1 to V_2 by steps of ΔV after the defined test time T. All limitations are the same as defined under Quick Start. The limitation of the max. generated number of spikes is related to the higher voltage of V_1 or V_2 .

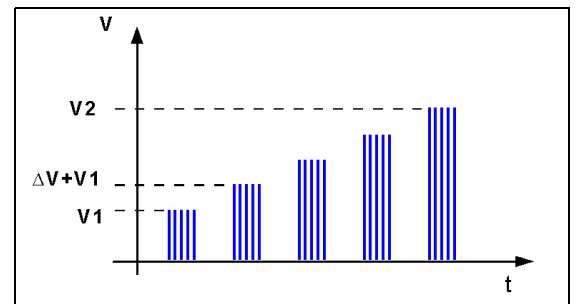

Frequency change after T by Δf

The spike frequency is increased from f_1 to f_2 , and then from f_2 to f_3 by steps of Δf after the defined test time T. All limitations are the same as defined under Quick Start. The limitation of the max. generated number of spikes is related to the higher frequency of f_1 , f_2 or f_3 .

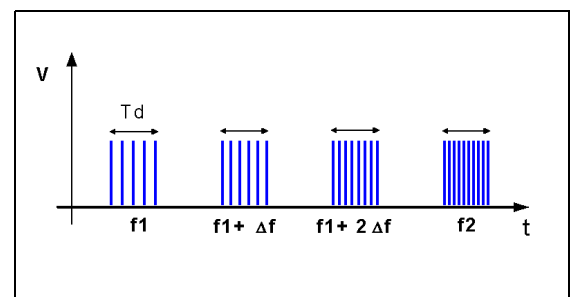

Frequency sweep in one single burst

During one single burst the frequency sweeps from f_1 to f_2 .
For this function the following limitations have to be respected:

t_r	\geq	100ms
f_1	\leq	f_2
t_d	\geq	5.0ms
t_d	\geq	$5 / f_1$
$t_r - t_d$	\geq	50ms

Duration change after T by Δt_4

The burst duration is increased from t_{4s} to t_{4e} by steps of Δt_4 after the defined test time T. All limitations are the same as defined under Quick Start. The limitation of the max. generated number of spikes is related to the higher duration of t_{4s} or t_{4e} .

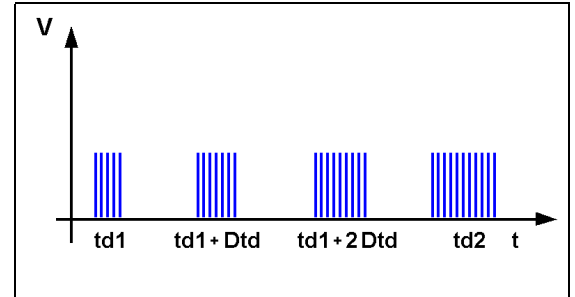
**Random burst release**

No repetition rate is selected. The single burst will be triggered randomly within the limits of 20 to 2000ms as time between two bursts. All limitations are the same as defined under Quick Start.

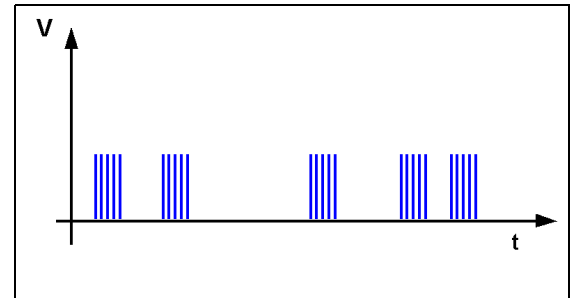
**Change coupling after T**

The coupling mode will be changed after the defined test time T. All modes will be tested.

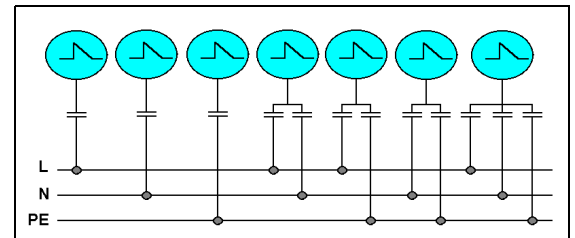
**Polarity change after T**

The polarity will be changed from + to - after the defined test time T.

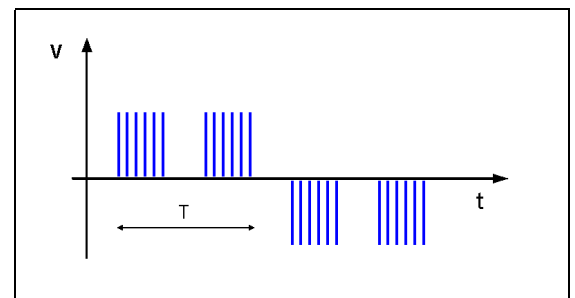

2.5. Test Routine as per IEC 61000-4-4 (2004-07) Ed 2

The display shows a list of test levels as per the standards IEC 61000-4-4. In the menu Service F4Change standard level you select between the burst frequency 5kHz and 100kHz.

Setting IEC 61000-4-4

STANDARD TEST ROUTINES			
F1	:	Level 1	260 V / 5.0 kHz
F2	:	Level 2	500 V / 5.0 kHz
F3	:	Level 3	1000 V / 5.0 kHz
F4	:	Level 4	2000 V / 5.0 kHz
F5	:	Level 5	4000 V / 5.0 kHz
F6	:	Level X - Level Y	

F1 F2 F3 F4 F5 F6 F7

Setting IEC 61000-4-4 Ed 2

STANDARD TEST ROUTINES			
F1	:	Level 1	260 V / 100.0 kHz
F2	:	Level 2	500 V / 100.0 kHz
F3	:	Level 3	1000 V / 100.0 kHz
F4	:	Level 4	2000 V / 100.0 kHz
F5	:	Level 5	4000 V / 100.0 kHz
F6	:	Level X - Level Y	

F1 F2 F3 F4 F5 F6 F7

The function key F5 selects a procedure which starts at test level X and stops at test level Y. The test level is changed automatically after the preselected test time T.
(X ≤ Y)

Page 3 (Show values)

Standard IEC 1000-4-4		Level 3	
V	= 2000V	f	: 100 kHz
td	= 0.8ms	tr	: 300ms
kop	= L N PE	+/-	: +
T	= 1:00min		

F1 F2 F3 F4 F5 F6

The Standard defines the burst duration at 100kHz with 0.75ms. The EFT 500 does not support a resolution of 0.05ms.

The burst duration at 100kHz is set to 0.8ms which is inside the specified tolerance of the standard of 0.75ms ± 20%

The functions START, CHANGE and PRINT are the same as defined under Quick Start.
The function key CHANGE can only handle the coupling, polarity and the test time.
All other parameters are defined by the standard.

2.6. Service

SERVICE	
F1	: Address EM TEST AG
F2	: Selftest
F3	: Set-up
F4	: Change standard levels
F5	: Print all

F1 F2 F3 F4 F5 F6 F7

F1 Addresses

All important data regarding EM TEST are indicated.

F2 Selftest

Selftest for check the key functions.

F3 Set-up

The software will clearly explain the set-up procedure.

F4 Change standard levels

This procedure allows the user to change the standard values to his actual requirements.

F5 Print all

All stored settings are printed to the serial interface RS 232.

2.7. Setup

SETUP
F1 : Change language
F2 : LCD backlighting
F3 : Interfaces
F4 : Keyboard-Beeper
F5 : Timer
F6 : Safety circuit

F1 F2 F3 F4 F5 F6 F7

Change language

The user can chose between two languages, German and English.

LCD backlighting

With the use of F2 the backlighting can be switched On or Off. Additionally the Auto Off function can be programmed to switch off the backlighting after a specified time the generator has not been in operation (1 - 30min).

Interfaces

This menu will help the user to define the status of the integrated serial and parallel interfaces, e.g. the baud rate of the RS 232 or the address of the IEEE interface.

Keyboard-Beeper

F1 is the selector for the beeper ON/OFF mode.

The beeper is always on when a test routine is finished. To indicate that a running test is finished the beeper sounds 3 times.

Timer

Pressing of F5 will show the total operating time of the test equipment.

Safety circuit

F6 shows the state of the security circuit. It can be switched on and off.

3. Test Equipment EFT 500

3.1. Specification of the test parameters

As per IEC 61000-4-4 the EFT pulses are specified as follows:

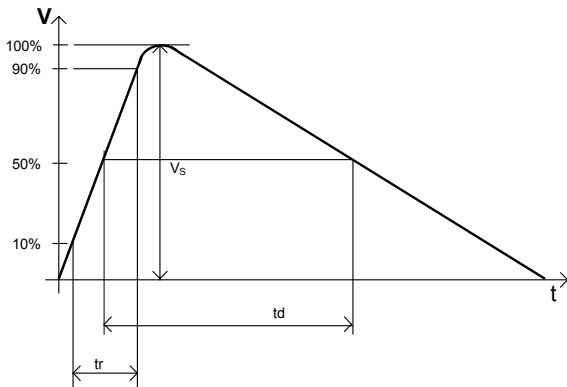

Definition of a single pulses

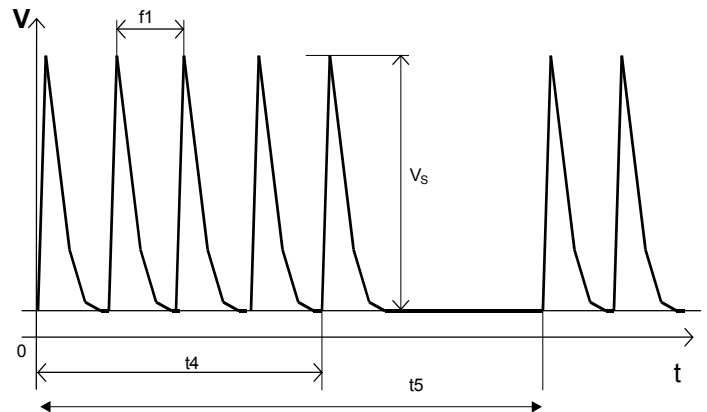

Definition of a complete burst

Parameter	on a 50 Ω load	on a 1000 Ω load
VS	125V – 2000V	250V - 4000V
Ri	50Ω	50Ω
td	50ns ±30%	35ns – 150ns
tr	5ns ±30%	5ns ±30%
f1	5kHz/2.5kHz	5kHz/2.5kHz
t4	15ms	15ms
t5	300ms	300ms

3.2. Burst generation

Discharge switch:

The discharge switch is a highly reproducible semiconductor switch. Spike frequencies up to 1000kHz are by a factor of 200 higher than recommended in the actual EFT standards. This means of course that also the pulse energy would be 200 times higher. This is not generally possible for the high voltage switch. Therefore the following limitation protects the pulse forming circuit against overload:

Voltage U	max. pulse / burst $td * f$	max. pulse / s $td * f / tr$
< 1'500V	1,000	10,000
>= 1'500V < 2'500V	1,000	linear decrease to 5,000
>= 2'500V	linear decrease to 500	linear decrease to 1,500

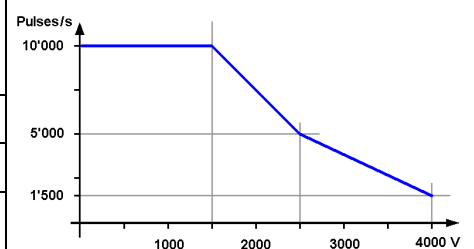

3.3. Coupling decoupling network

The decoupling part of the coupling network has to:

- filter the interference pulses in the direction to the power supply;
- protect other systems that are connected to the same power supply and
- realize a high impedance of the power supply, e.g. battery supply.

3.3.1. Coupling/decoupling network for ac/dc power lines

The coupling network has to couple the interference pulses to the lines of a power supply system (AC or DC). As coupling devices capacitors of sufficient strength and bandwidth shall be used according to IEC 61000-4-4.

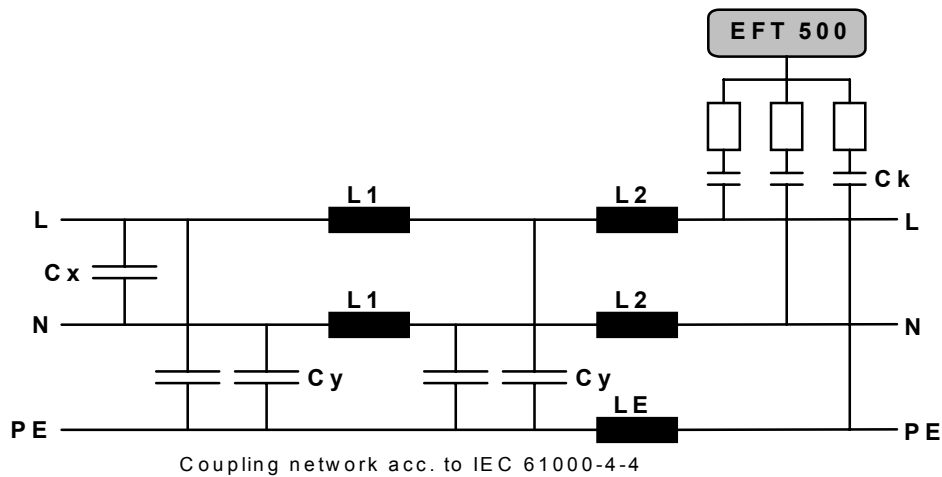

The coupling on signal lines can usually not be effected capacitively without interfering with the signal flow. It is often impossible to contact the required circuit (direct), e. g. coaxial or shielded cables. In this case the coupling is realized with the capacitive coupling clamp. The interference simulator can be connected on both sides of the coupling clamp.

3.3.2. Capacitive coupling clamp

- The coupling clamp is not matched by 50 ohm. If the clamp is matched there exists an additional magnetic coupling, which may cause completely different test results.
- The clamp should be placed in a distance of 0.5m to the equipment under test. When using shorter distances, the EUT may be influenced by radiation.
- If the EUT is built up by two different equipment, the test should be conducted on each single equipment with the required distance.

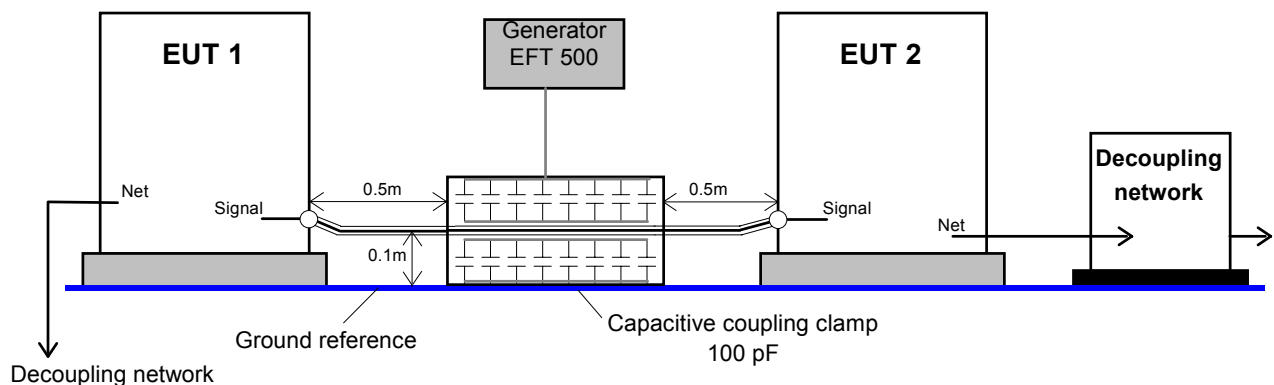

3.4. Burst Test Setup

- The test generator and the coupling network should be connected to the reference ground plane (acc. to high frequency requirements).
- The equipment under test must be isolated from the reference ground plane. The distance should be 10cm. Being part of the EUT, these requirements are also recommended for all connected cables. The EUT should only be grounded if this is recommended by the installation guideline. For safety reasons, the test without any ground connection should be conducted as well (at 100MHz 1m ground cable has an impedance of about 600 ohm)
- Whenever possible the test set-up and the cabling should always be the same; e.g. for testing power lines it would be possible to fix the cables on the test table for all tests in the same way.
- Lines under test and all other lines should be decoupled strictly.

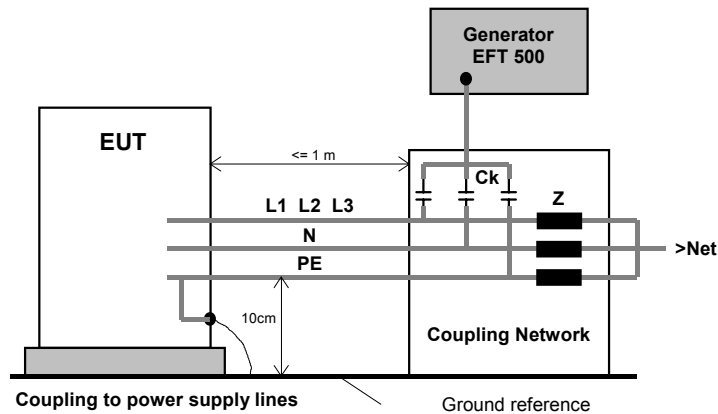

3.5. Computer setup for EFT/Burst testing.

During immunity tests high frequency interference is generated. Due to the length of the connected lines, a certain part of this energy will be transformed into radiated interference.

Therefore the operator shall be aware that systems and installations in the neighborhood, even those not being part of the test set-up can be disturbed.

Especially for fully automated test systems, where simple computers may be used, EMC problems within the test system may occur. To avoid such disturbances in the following paragraphs some information is given to which the operator has to taken care:

- EM TEST generators are tested with the maximum test level. If no damage has been occurred the equipment must be seen as immune.
- The interference always will enter into a system at the weakest part. Within a computer controlled system the weakest unit is almost the computer with its interconnection lines and the peripheral equipment.
- The most critical test concerning the above mentioned problems is the burst test according to IEC 1000-4-4. This is a high frequency test, which may radiate extreme interference fields to the environment.

Concerning the test set-up the following points be explained:

1. The burst generator must be connected very good to the ground reference plane on the table.
2. The ground reference plane shall be connected to the protective earth system. For tests within a shielded room the connection shall be made to the walls of the room.
3. The test set-up shall have one single ground reference point (not several)

GROUND LOOPS SHALL BE STRICTLY AVOIDED

4. The central ground reference point shall be located where the EFT generator is connected to the ground reference plane. At the same point the reference ground plane shall be connected to the protective earth system or to the shielded room.

For conducting the test the following points shall be taken under consideration:

1. It is not allowed to touch the EUT or the cables under test during a running test. The test results will be influenced and are no more reproducible.
2. If the operator in contrary touches directly the EUT or the connected lines increased radiation from the test set-up is generated. The operator itself will radiate and/or will cause ground currents into the whole environment.
3. As larger the dimensions of an EUT are, as higher the radiation of high frequency energy will be.
4. Especially the capacitive coupling clamp with its length of 1m radiates.
5. Auxiliary equipment as well as computer can be influenced directly due to the radiation.

Remarks:

Even the use of fiber-optic links for the communication between a computer and EFT does not help in case of direct radiation. The computer and its lines will be directly influenced and the data transmission will be disturbed.

6. The influence of direct radiation can be reduced by increasing the distance between a computer and the test set-up. In any case a minimum distance of 3m shall be available.

It is not only the length of the cable but also the physical distance between computer and test set-up which is important to take care to.

7. It shall be strictly avoided to put the computer directly onto the ground reference plane of the test set-up. The computer then is part of the test set-up and will also be tested. Mostly all computers are not immune to this test and will be disturbed.

What to say about the computer:

1. Do not use oldest equipment available in your company. Actual computer show better behavior to what EMC concerns.
2. **Do not use notebooks for this application. Laptops are fully manufactured within a plastic housing and therefore are very sensitive to all kind of interference.**
4. It would be better to use tower- or mini-tower equipment. They are at least partially screened. The interface connectors are mounted on metallic surfaces so that the screen of the communication lines can be connected to the chassis.
5. The screens of the RS 232 and IEEE cables must be connected to the chassis of the instruments at both sides, at the computer and at the EFT generator.
6. **The communication cables, RS 232 and IEEE, shall be screened. Do not use standard cables, consumer products with plastic connectors.**
These cable types are using mostly very bad designed cable screens. The contact to the housing of the connector is mostly realized with a small cable, which is very bad under the aspect of rf screening. Please take care that the screen is connected very good to the metallic housing of the connector and that the connector is screwed to the housing of the generator.
This mostly is the problem when using the RS 232 interface. Especially those cables are badly designed. For IEEE cables very good products are available (e.g. HP).
7. The weakest parts within the computer system are the peripherals, as keyboard and mouse. Both products are not designed to operate under these severe conditions.

It is very easy to make the design better. The operator would be able to do it for himself.

What is the problem ?

The screen of the cables between a computer and the keyboard (mouse) are soldered directly to the printed circuit board.

The screen shall not be soldered to the print, but to another „ground reference plane“.

e.g. put into the keyboard, directly under the keyboard print a broad copper foil area. Connect the screen of the cable to this copper foil, without any connection to the print. You will see a dramatic change to better results.

4. Technical data

4.1. EFT Electrical Fast Transients Burst as per IEC 61000-4-4

Test Level	
Open circuit	200V - 4400V \pm 10% Step 10V
Wave shape into a 50 Ω load	100V – 2200V
Rise time tr	5ns \pm 30%
Pulse duration td	50ns \pm 30%
Wave shape into a 1000 Ω load	200V – 4400V
Rise time tr	5ns \pm 30%
Pulse duration td	35ns - 150ns
Source impedance	Zq = 50 Ω \pm 20%
Polarity	positive / negative
Trigger	
Trigger of bursts	AUTO, MANUAL, EXTERN
Synchronization	0° - 360°
Burst duration td	0.1ms - 999.9ms
Burst repetition rate tr	10ms - 9999ms
Spike frequency f	0.1kHz - 1000kHz
Test duration T	0:01 min - 99:59 min
Output	
Direct via 50 Ω coaxial connector	To connect ext. coupling devices
Coupling network	To L, N, PE all combinations
DUT power mains supply	AC 250 V / 16 A / 50/60 Hz
	DC 250V/10A
Test routines	
Quick Start	Immediate start, all parameters adjustable during a running test
Standard test as per	IEC 61000-4-4 level 1 ... level 5
	Level X - Level Y
User test routines	Customized test routines
	Voltage change after T by ΔV
	Frequency change after T by Δf
	Frequency sweep in one single burst
	Change duration after T by Δtd
	Change polarity after T
	Statistical burst release
	Synchronized at fixed angle

Safety

Safety circuit Control input (short circuit)
Design as per IEC 1010, EN 61010

Interfaces

RS 232 serial, 1200 - 19200 Baud
IEEE parallel, addresses 1-30
CN port Control of CNE 503 for 3-ph testing

General data

Dimensions 19" / 3 HUE
Weight approx. 8kg
Power supply 115V/230V +10/-15% 50/60Hz
Fuses 2 x T 1A slow blow

5. Maintenance

5.1. General

The generator is absolutely maintenance-free by using a solid state semiconductor switch to generate transients.

5.2. Test set-up



When setting up the test national and international regulations regarding human safety have to be guaranteed.

It is recommended to connect the simulator to the ground reference plane of the test set-up.

The generators of the series 500, UCS, VCS, CSS, TSS and CNI, can be linked together to a fully automotive test set-up.

The set-up communicates via the IEEE / GPIB bus and is controlled by ISMIEC software. For setting up the system see the following figures:

Each generator can be operated individual as a single equipment.

5.3. Calibration and verification

The EM Test equipment are calibrated in the factory and marked with a calibration-tag. The measuring instrument is traceable to the Swiss Federal Office of Metrology.

The calibration date is marked. The validity of the calibration is in the area of responsibility of the users quality system.

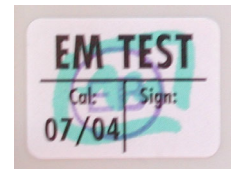

Example: EM Test calibration-tag

Please refer to the corresponding standard before proceed a calibration or verification. The standard describes the procedure, the tolerances and the necessary auxiliary means. There are suitable calibrations adapters to use. All calibrations and verifications are always without mains supply voltage on the impulse- or coupling network output.



Danger

Before starting the calibration or verification
remove the EUT Mains Supply
 from the generator and from the coupling network

6. Delivery Groups

6.1. Basic equipment

- EFT/burst generator type EFT 500
- Mains cable
- Mains cable for the EUT supply
- Adapter for power cable
- Manual
- Calibration certificate

6.2. Accessories and options

- 50 Ω matching resistor (1:100) type KW 50
- 1000 Ω matching resistor (1:1000) type KW 1000
- Capacitive coupling clamp HFK as per IEC 61000-4-4
- External coupling/decoupling network 3 - phase CNE 503
 - EUT mains supply 400 V rms max. // 480V for USA
 - Nominal current $I_n = 16 \text{ A} / 32\text{A} / 63\text{A} / 100 \text{ A rms}$
 - Frequency 50/60 Hz
 - Coupling to all lines . Lx, N, PE
 - 50 Ω Burst output
 - The coupling will be controlled by the EFT 500
- ITP immunity test probe set
- User software "ISM IEC"
Test, analysis and documentation with windows (see separate documentation)

7. Appendix

7.1. Declaration of CE-Conformity

Manufacturer : **EM TEST AG**
 Address: Sternenhofstr. 15
 CH 4153 Reinach
 Switzerland

declares, that under its sole responsibility, the product's listed below, including all their options, are in conformity with the applicable CE directives listed below using the relevant section of the following EC standards and other normative documents.

Product's name: Burstgenerator EFT 500
 Model Number(s) EFT 500

Low Voltage Directive 73/23/EEC

Standard to which conformity is declared:

EN 61010-1:1993

Safety

EMC Directive 89/336/EEC

Standard(s) to which conformity is declared:

Emissions: EN 50022:1987, Class A
 EN 50081-2 : 1992 EN 61000-2-3 A14: 2000

Conducted and radiated.
 Harmonics

Immunity: EN 50082-2: 1995	EN 61000-4-2:1995 EN 50413:1993 EN 61000-4-6:1997 EN 61000-4-4: 1995 EN 61000-4-5: 1996 EN 61000-4-11: 1994	Electrostatic Discharges RF Electromagnetic Field Conducted RF Electrical Fast Transient / Burst Surge DIPS & Voltage Variations
----------------------------	--	---

European representative
 EM TEST GmbH
 Lünenerstr. 211
 D 59174 Kamen
 Tel: 00492307-18042
 Fax: 00492307-17050

Manufacturer
 EM TEST AG
 Sternenhofstr. 15
 CH 4153 Reinach
 Tel: 004161-7179191
 Fax: 004161-7179199





By U. Flor
 General manager
 Place Kamen, Germany
 Date 11. November 2002

H. Kunkel
 Design and Research
 Reinach BL, Switzerland
 11. November 2002

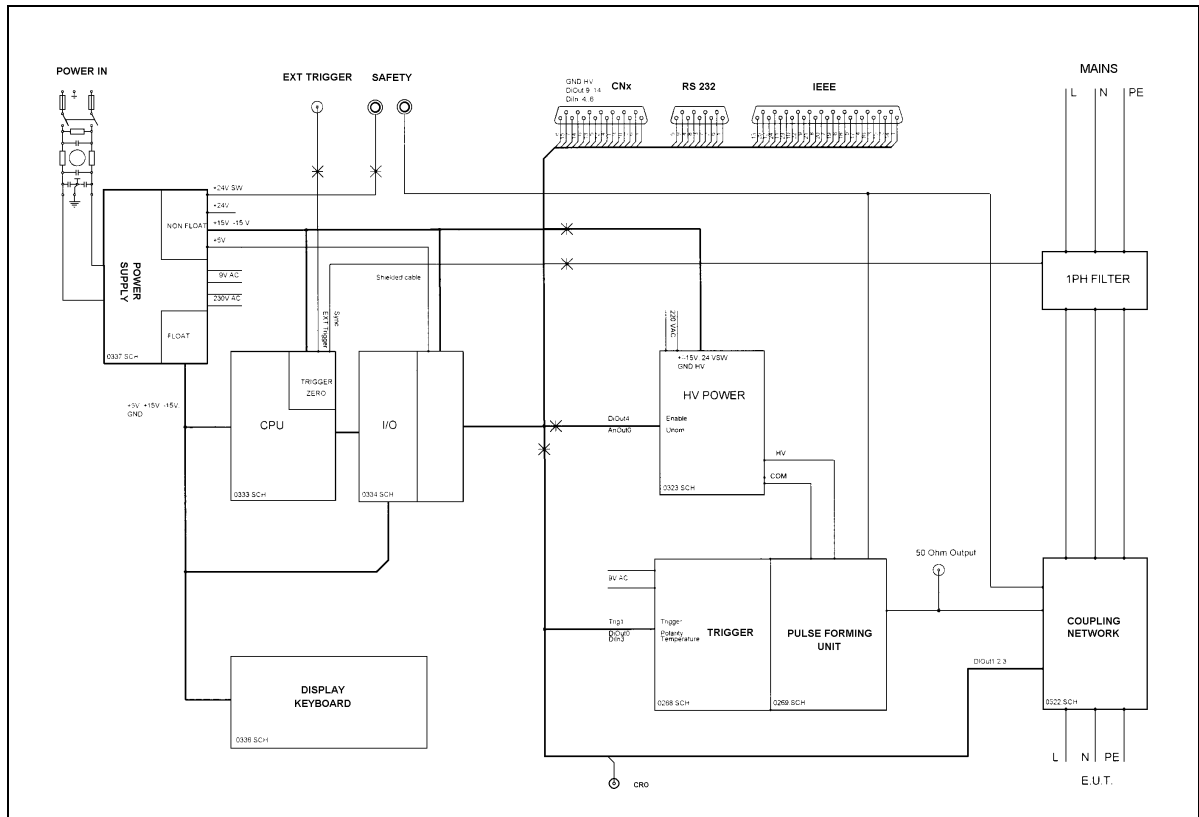
7.2. EFT 500 - General Diagram

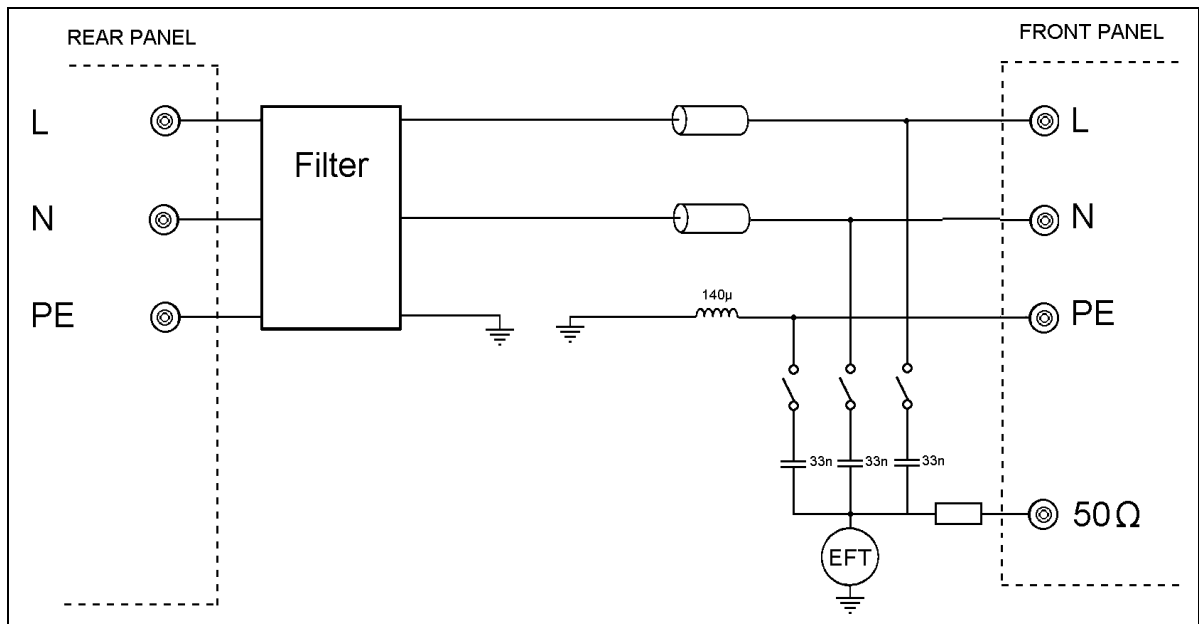

7.3. EFT 500 - Overview



7.4. EFT 500 Menu overview

Page 0	Page 1	Page 2	Page 3	Page 4	Page 5
EM TEST EFT 500 Burst 5 / 50ns V3.20 SWN: 000115	Main menu F1 Quick Start F2 User test routines F3 Standard test routines F7 Service	Quick Start F1 Start F2 Change F3 Continue F7 Print	Start Starting the test procedure Change Selection the parameters Continue Print (Set-up)		
		User test routines F1 : Customized test routines F2 : Voltage change after T by ΔV F3 : Frequency change after T by Δf F4 : Frequency sweep in one single burst F1 : Change duration after T by Δt_d F2 : Change polarity after T F3 : Statistical burst release F4 : Synchronized at fixed angle	Select store Each user test routine includes 7 stores in which specific test routines can be saved and selected.	User test routines F1-F7 F1 Start F2 Change F3 Continue F5 Save F7 Print	Start (test procedure) Change Select the parameters Continue Save Store the parameters Print (Set-up)
		Standard test routines F1 : Level 1 250 V / 5 / 100 kHz F2 : Level 2 500 V / 5 / 100 kHz F3 : Level 3 1000 V / 5 / 100 kHz F4 : Level 4 2000 V / 5 / 100 kHz F5 : Level 5 4000 V / 5 / 100 kHz F6 : Level X - Level Y	Test level 1..5 / x..y F1 Start F2 Change F3 Continue F7 Print	Test level 1 .. 4 Start Start of the test routine Change Select new parameters Continue Print /Set-up	
		Service F1 Addresses F2 Selftest F3 Set-up F4 Change standard test levels F5 Print all settings	Addresses All addresses of EM TEST AG and GmbH and URL address		
			Self-test		
			Set-up F1 Change language F2 LCD backlighting F3 Interfaces F4 Keyboard beeper F5 Timer F6 Safety circuit	Change language German/English LCD backlighting On/Off or Auto Interfaces Select parameters Keyboard beeper (On/Off) Running time display Safety circuit (On/Off)	
			Change standard levels F1..F5 Change the levels F6..F7 Change to standards	Change U, f, t4, t5, pol can be changed Set to standard (Yes/No)	
			Print all F7 Print	Print Print all stores	