

# R&S® ZNA VECTOR NETWORK ANALYZER

## Specifications

3  
year  
warranty

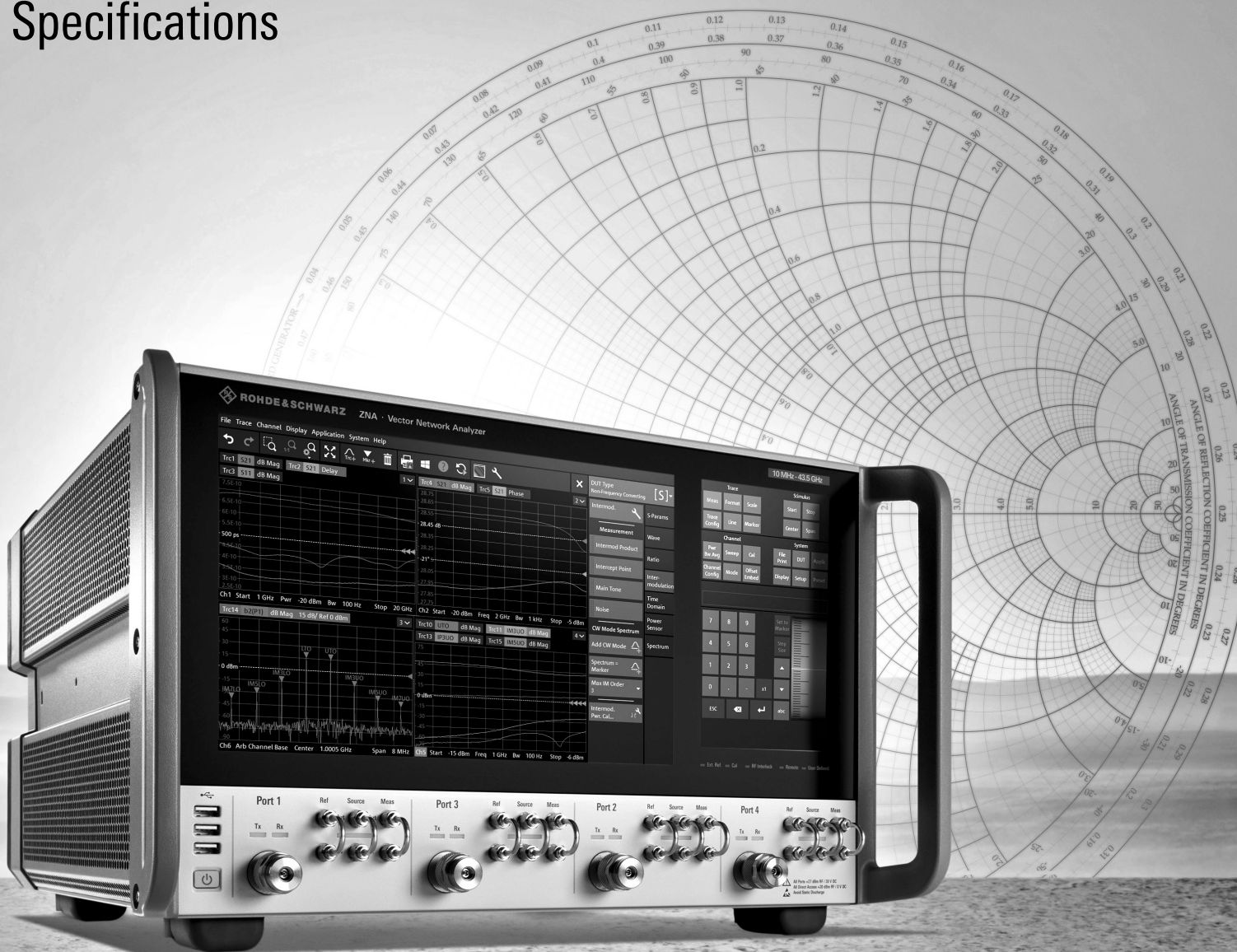

Data Sheet  
Version 15.00

**ROHDE & SCHWARZ**

Make ideas real



# CONTENTS

<b>Key performance</b> .....	<b>4</b>
<b>Definitions</b> .....	<b>6</b>
<b>Measurement range</b> .....	<b>7</b>
<b>Dynamic range</b> .....	<b>8</b>
<b>Measurement speed</b> .....	<b>10</b>
<b>Measurement accuracy of the R&amp;S®ZNA26</b> .....	<b>12</b>
<b>Measurement accuracy of the R&amp;S®ZNA43, 2.92 mm interface</b> .....	<b>13</b>
<b>Measurement accuracy of the R&amp;S®ZNA43, 2.4 mm interface</b> .....	<b>14</b>
<b>Measurement accuracy of the R&amp;S®ZNA50</b> .....	<b>15</b>
<b>Measurement accuracy of the R&amp;S®ZNA67</b> .....	<b>16</b>
<b>Reflection measurement accuracy of the R&amp;S®ZNA26 and R&amp;S®ZNA43</b> .....	<b>18</b>
<b>Transmission measurement accuracy of the R&amp;S®ZNA26 and R&amp;S®ZNA43</b> .....	<b>18</b>
<b>Reflection measurement accuracy of the R&amp;S®ZNA50 and R&amp;S®ZNA67</b> .....	<b>19</b>
<b>Transmission measurement accuracy of the R&amp;S®ZNA50 and R&amp;S®ZNA67</b> .....	<b>19</b>
<b>Effective system data</b> .....	<b>20</b>
<b>Uncorrected system data</b> .....	<b>22</b>
<b>Test port output</b> .....	<b>24</b>
<b>Test port input</b> .....	<b>27</b>
<b>Display</b> .....	<b>29</b>
<b>Internal PC</b> .....	<b>29</b>
<b>Front panel connectors</b> .....	<b>29</b>
<b>Rear panel connectors</b> .....	<b>29</b>
<b>Options</b> .....	<b>30</b>
R&S®ZNA-B7 memory extension for data streaming.....	30
R&S®ZNA-B8 mmWave converter LO.....	30
R&S®ZNA-B15 RFFE GPIO interface .....	31
R&S®ZNA-B26 direct IF access .....	32
R&S®ZNA-B91 trigger and control I/O board.....	32
R&S®ZNA26-B16, R&S®ZNA43-B16, R&S®ZNA50-B16 and R&S®ZNA67-B16 direct source and receiver access .....	33
R&S®ZNA26-B21/-B22/-B23/-B24, R&S®ZNA43-B21/-B22/-B23/-B24, R&S®ZNA50-B21/-B22/-B23/-B24 and R&S®ZNA67-B21/-B22/-B23/-B24 source step attenuators.....	34
R&S®ZNA26-B31/-B32/-B33/-B34, R&S®ZNA43-B31/-B32/-B33/-B34, R&S®ZNA50-B31/-B32/-B33/-B34 and R&S®ZNA67-B31/-B32/-B33/-B34 receiver step attenuators.....	34
R&S®ZNA26-B41/-B42/-B43/-B44, R&S®ZNA43-B41/-B42/-B43/-B44, R&S®ZNA50-B41/-B42/-B43/-B44 and R&S®ZNA67-B41/-B42/-B43/-B44 internal pulse modulators .....	34
R&S®ZNA26-B161/R&S®ZNA43-B161 source monitor access port 1 and R&S®ZNA26-B163/R&S®ZNA43-B163 source monitor access port 1 and port 3 .....	35
R&S®ZNA26-B212, R&S®ZNA43-B212 internal combiner, port 1 and port 2 .....	36
R&S®ZNA26-B213, R&S®ZNA43-B213 internal combiner, port 1 and port 3 .....	37
R&S®ZNA26-B302, R&S®ZNA43-B302 low-noise amplifier, port 2.....	38
R&S®ZNA26-B501, R&S®ZNA43-B501 low power spurious reduction, port 1 .....	39

R&S®ZNA-K1 spectrum analyzer mode (based on fast Fourier transform) .....	40
R&S®ZNA-K5 vector corrected converter measurements .....	40
R&S®ZNA-K6 phase-coherent source control .....	40
R&S®ZNA-K8 mmWave converter support .....	40
R&S®ZNA-K9 group delay measurements .....	41
R&S®ZNA-K30 noise figure measurement .....	41
R&S®ZNA-K980 health and utilization monitoring service (HUMS) · .....	41
<b>General data .....</b>	<b>42</b>
Dimensions (in mm) .....	43
<b>Ordering information .....</b>	<b>45</b>

## Key performance

Dynamic range	> 129 dB (specification, without options), 147 dB (typ., with options), up to 170 dB (maximum attainable range, allowing full 2-port correction)
Sensitivity	> -120 dBm (1 Hz IF bandwidth) (specification, without options), -162 dBm (1 Hz IF bandwidth) (meas., with options) <sup>1</sup>
Power sweep range	100 dB (typ.) continuous electronic sweep range, can be shifted using mechanical step attenuators
Source power linearity	0.2 dB (typ., from -40 dBm to +10 dBm)
Receiver compression	0.05 dB (typ., up to +8 dBm with reference to -10 dBm, at test port)
Trace noise	0.005 dB (specification, RMS), 0.002 dB (typ., RMS) (10 GHz, 100 kHz measurement bandwidth, 0 dB reflection)
Speed	10 MHz to 43.5 GHz, 500 kHz measurement bandwidth, 1601 points, 2-port calibration, sweep time: 96 ms (nom.)

### Four port instruments offering full flexibility<sup>2</sup>

Up to 4 sources (independently configurable, phase coherent, phase controlled), 5th source, e.g. for LO supply	allows complex measurement setups without external equipment on mixers and frequency converters such as IM, group delay and deviation from linear phase; mixer and frequency converter measurements up to the terahertz range, phased array antenna testing, active load pull on fundamental and harmonic frequencies, etc.
Optional rear panel LO out	mmWave converter setups with up to 4 converters without external signal generator; high-power (typ. +25 dBm) LO signal up to 26.5 GHz for mixer measurements as a 5th source
Optional second LO source	mixer and frequency converter measurements with doubled speed and optimized trace noise, e.g. for mixer group delay and deviation from linear phase (K9 option) using 1 kHz measurement bandwidth; group delay trace noise peak-to-peak: 200 ps reduced to 15 ps
2 true receivers per port, resulting in 8 true receivers for 4-port model (no multiplexing)	true parallel and coherent data acquisition, e.g. for antenna array tests and antenna test systems, starting from 100 kHz; infinite data point capture (K28 option) with circular buffer and continuous data transfer over LAN or USB
Up to 4 pulse modulators, up to 8 pulse generators, enhanced trigger/sync/ctrl/ I/O	versatile pulse generation and visualization in timing diagram combined with enhanced triggering capabilities; timing control of external devices, e.g. pulse modulators, power supply, oscilloscopes or DUT, minimum pulse width: 40 ns
Optional direct IF access (in/out)	IF input for mmWave converter and antenna measurement systems, 1 GHz bandwidth available, IF output up to 2 GHz bandwidth for external pulse analysis
Selectable reference signal access (1 GHz external reference)	synchronization of external equipment (e.g. signal generators), resulting in improved performance for mmWave converters up to terahertz frequencies
Optional internal combiner, internal LNA, source monitor, direct receiver access, source attenuators, receiver attenuators, reverse coupler operation	various test-set options for complex measurement setups

<sup>1</sup> Measured at 1 kHz measurement bandwidth, normalized to 1 Hz.

<sup>2</sup> Respective options required.

**Two port instruments tailored for specific applications <sup>2</sup>**

Up to 2 sources (independently configurable, phase coherent, phase controlled), 3rd source, e.g. for LO supply	allows complex measurement setups without external equipment on mixers and frequency converters such as IM, group delay and deviation from linear phase; mixer and frequency converter measurements up to the terahertz range, phased array antenna testing, active load pull on fundamental and harmonic frequencies, etc.
Optional rear panel LO out	mmWave converter setups with up to 2 converters without external signal generator; high-power (typ. +25 dBm) LO signal up to 26.5 GHz for mixer measurements as a 3rd source
Optional second LO source	mixer and frequency converter measurements with doubled speed and optimized trace noise, e.g. for mixer group delay and deviation from linear phase (K9 option) using 1 kHz measurement bandwidth; group delay trace noise peak-to-peak: 200 ps reduced to 15 ps
2 true receivers per port, resulting in 4 true receivers for 2-port model (no multiplexing)	true parallel and coherent data acquisition, e.g. for antenna array tests and antenna test systems, starting from 100 kHz; infinite data point capture (K28 option) with circular buffer and continuous data transfer over LAN or USB
Up to 2 pulse modulators, up to 4 pulse generators, enhanced trigger/sync/ctrl/ I/O	versatile pulse generation and visualization in timing diagram combined with enhanced triggering capabilities; timing control of external devices, e.g. pulse modulators, power supply, oscilloscopes or DUT, minimum pulse width: 40 ns
Optional direct IF access (in/out)	IF input for mmWave converter and antenna measurement systems, 1 GHz bandwidth available, IF output up to 2 GHz bandwidth for external pulse analysis
Selectable reference signal access (1 GHz external reference)	synchronization of external equipment (e.g. signal generators), resulting in improved performance for mmWave converters up to terahertz frequencies
Optional internal combiner, internal LNA, source monitor, direct receiver access, source attenuators, receiver attenuators, reverse coupler operation	various test-set options for complex measurement setups

**Software options for comprehensive device characterization**

- Mixer phase measurements without external auxiliary mixer(s) and without phase reference
- Noise figure measurements on mixers and amplifiers: user guidance offering straight forward DUT setups
- Arbitrarily configurable sources and receivers, e.g. for frequency converting measurements, full flexibility
- Embedded LO converter (group delay and deviation from linear phase) characterization, including AM/AM and AM/PM conversion; intermodulation, source and load match correction, real time LO tracking
- Phase-coherent stimulation and measurement with up to 4 sources; excellent phase accuracy of 0.1° at 10 GHz (meas); supports arbitrary phase and amplitude control, e.g. create arbitrary phase fronts, balanced drive, quadrature drive
- True-differential measurements with full set of analysis capabilities, e.g. compression point, THD for amplifiers and I/Q-mixers
- Spectrum analysis projected to calibration plane, noise level down to -162 dBm (1 Hz IF bandwidth, meas) with optional low noise amplifier and reverse coupler operation; parallel sweeping of up to four receivers in spectrum sweep mode
- Time domain measurements with increased time resolution for narrowband DUTs by resolution enhancement factor functionality
- De-embedding functions per the IEEE P370 standard, plus enhanced algorithms from industry-leading third parties for fixture characterization
- Real-time measurement uncertainty utilizing the traceability chain of METAS VNA Tools, integrated verification testing with traceability to various National Metrology Institutes

# Definitions

## General

Product data applies under the following conditions:

- Three hours storage at ambient temperature followed by 30 minutes warm-up operation
- Specified environmental conditions met
- Recommended calibration interval adhered to
- All internal automatic adjustments performed, if applicable

## Specifications with limits

Represent warranted product performance by means of a range of values for the specified parameter. These specifications are marked with limiting symbols such as  $<$ ,  $\leq$ ,  $>$ ,  $\geq$ ,  $\pm$ , or descriptions such as maximum, limit of, minimum. Compliance is ensured by testing or is derived from the design. Test limits are narrowed by guard bands to take into account measurement uncertainties, drift and aging, if applicable.

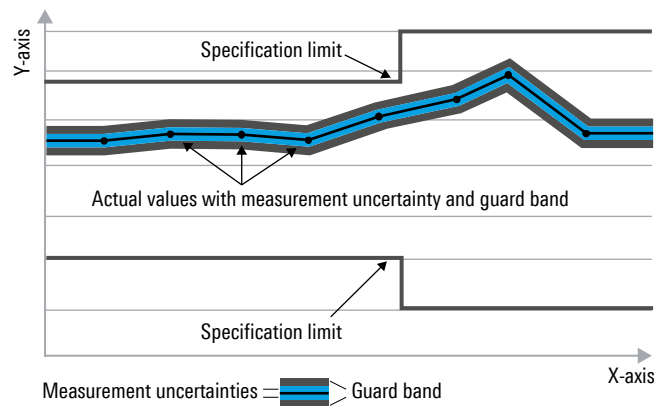

## Non-traceable specifications with limits (n. trc.)

Represent product performance that is specified and tested as described under “Specifications with limits” above. However, product performance in this case cannot be warranted due to the lack of measuring equipment traceable to national metrology standards. In this case, measurements are referenced to standards used in the Rohde & Schwarz laboratories.

## Specifications without limits

Represent warranted product performance for the specified parameter. These specifications are not specially marked and represent values with no or negligible deviations from the given value (e.g. dimensions or resolution of a setting parameter). Compliance is ensured by design.

## Typical data (typ.)

Characterizes product performance by means of representative information for the given parameter. When marked with  $<$ ,  $>$  or as a range, it represents the performance met by approximately 80 % of the instruments at production time. Otherwise, it represents the mean value.

## Nominal values (nom.)

Characterize product performance by means of a representative value for the given parameter (e.g. nominal impedance). In contrast to typical data, a statistical evaluation does not take place and the parameter is not tested during production.

## Measured values (meas.)

Characterize expected product performance by means of measurement results gained from individual samples.

## Uncertainties

Represent limits of measurement uncertainty for a given measurand. Uncertainty is defined with a coverage factor of 2 and has been calculated in line with the rules of the Guide to the Expression of Uncertainty in Measurement (GUM), taking into account environmental conditions, aging, wear and tear.

Device settings and GUI parameters are designated with the format “parameter: value”.

Non-traceable specifications with limits, typical data as well as nominal and measured values are not warranted by Rohde & Schwarz.

In line with the 3GPP/3GPP2 standard, chip rates are specified in million chips per second (Mcps), whereas bit rates and symbol rates are specified in billion bit per second (Gbps), million bit per second (Mbps), thousand bit per second (kbps), million symbols per second (MSPS) or thousand symbols per second (ksps), and sample rates are specified in million samples per second (Msample/s). Gbps, Mcps, Mbps, MSPS, kbps, ksps and Msample/s are not SI units.

## Measurement range

Impedance		50 $\Omega$
Test port connector	R&S®ZNA26	3.5 mm, male, ruggedized
	R&S®ZNA43, 2.4 mm interface	2.4 mm, male, ruggedized
	R&S®ZNA43, 2.92 mm interface	2.92 mm, male, ruggedized
	R&S®ZNA50	2.4 mm, male, ruggedized
	R&S®ZNA67	1.85 mm, male, ruggedized
Number of test ports	R&S®ZNA26	2 or 4
	R&S®ZNA43	2 or 4
	R&S®ZNA50	2 or 4
	R&S®ZNA67	2 or 4
Frequency range <sup>3</sup>	R&S®ZNA26	10 MHz to 26.5 GHz
	R&S®ZNA43	10 MHz to 43.5 GHz
	R&S®ZNA50	10 MHz to 50 GHz
	R&S®ZNA67	10 MHz to 67 GHz
DC block	R&S®ZNA26, R&S®ZNA43, R&S®ZNA50 and R&S®ZNA67	standard

<b>Static frequency accuracy</b>	The static frequency accuracy is determined with the formula <i>(time since last adjustment in years × aging per year) + temperature drift + achievable initial calibration accuracy</i> using the values specified below. Depending on whether or not the R&S®ZNA-B4 precision frequency reference option is installed, the standard or the improved value have to be taken into account.	
Aging per year	standard	$\pm 1 \times 10^{-6}$
	with R&S®ZNA-B4 precision frequency reference option	$\pm 1 \times 10^{-7}$
Temperature drift (+5 °C to +40 °C)	standard	$\pm 1 \times 10^{-6}$
	with R&S®ZNA-B4 precision frequency reference option	$\pm 1 \times 10^{-8}$
Achievable initial calibration accuracy	standard	$\pm 5 \times 10^{-7}$
	with R&S®ZNA-B4 precision frequency reference option	$\pm 5 \times 10^{-8}$

Frequency resolution		1 Hz
Number of measurement points	per trace	1 to 100001
Measurement bandwidth	1/1.5/2/3/5/7 steps	
	base unit	1 Hz to 1.5 MHz
	with R&S®ZNA-K17 increased IF bandwidth (30 MHz) option	1 Hz to 30 MHz
Analog frontend bandwidth	10 MHz to 5 GHz	50 MHz (nom.)
	5 GHz to 67 GHz	2 GHz (nom.)

<sup>3</sup> Specified and typical data given in this data sheet applies to the R&S®ZNA26, R&S®ZNA43, R&S®ZNA50 and R&S®ZNA67; note the respective frequency ranges.

## Dynamic range

The receiver noise floor referred to in the following is defined as the RMS value of the data trace of the transmission magnitude, which is produced by noise and crosstalk with the test ports short-circuited. The specification applies at 10 Hz measurement bandwidth, without user correction applied. The dynamic range can be increased by using a measurement bandwidth of 1 Hz. Crosstalk does not limit the dynamic range. Dynamic range performance is specified between port 1 and port 2 as well as between port 3 and port 4 (4-port model). Otherwise, dynamic range performance is typical.

	Base unit			Base unit + R&S®ZNA-B3n <sup>4, 5</sup>			
	Specification	Typical	Measured	Specification	Typical	Measured	
<b>System dynamic range</b>	R&S®ZNA26, R&S®ZNA43, R&S®ZNA50 and R&S®ZNA67						
Difference between maximum output power and receiver noise floor (for data with additional step attenuator(s) or direct source and receiver access, refer to "Options")	10 MHz to 30 MHz	> 86 dB	96 dB		> 86 dB	96 dB	
	30 MHz to 100 MHz	> 103 dB	113 dB		> 103 dB	113 dB	
	100 MHz to 500 MHz	> 117 dB	127 dB		> 117 dB	127 dB	
	500 MHz to 1 GHz	> 126 dB	136 dB		> 131 dB	141 dB	
	1 GHz to 16 GHz	> 129 dB	139 dB		> 137 dB	147 dB	
	16 GHz to 20 GHz	> 127 dB	137 dB		> 135 dB	145 dB	
	20 GHz to 30 GHz	> 123 dB	133 dB		> 131 dB	141 dB	
	30 GHz to 40 GHz	> 117 dB	127 dB		> 124 dB	134 dB	
	R&S®ZNA43, 2.4 mm interface						
	40 GHz to 43.5 GHz	> 106 dB	116 dB		> 112 dB	122 dB	
	R&S®ZNA43, 2.92 mm interface						
	40 GHz to 43.5 GHz			116 dB			122 dB
	R&S®ZNA50 and R&S®ZNA67						
	40 GHz to 50 GHz	> 106 dB	116 dB		> 112 dB	122 dB	
R&S®ZNA67							
50 GHz to 67 GHz	> 102 dB	112 dB		> 107 dB	117 dB		

	Base unit + R&S®ZNAxx-B16 <sup>6</sup>			Base unit + R&S®ZNAxx-B16 + R&S®ZNAxx-B2n + R&S®ZNAxx-B3n <sup>4</sup>			
	Specification	Typical	Measured	Specification	Typical	Measured	
<b>System dynamic range</b>	R&S®ZNA26, R&S®ZNA43, R&S®ZNA50 and R&S®ZNA67						
Difference between maximum output power and receiver noise floor (for data with additional step attenuator(s) or direct source and receiver access, refer to "Options")	10 MHz to 30 MHz	> 86 dB	96 dB		> 85 dB	95 dB	
	30 MHz to 100 MHz	> 103 dB	113 dB		> 102 dB	112 dB	
	100 MHz to 500 MHz	> 117 dB	127 dB		> 116 dB	126 dB	
	500 MHz to 1 GHz	> 126 dB	136 dB		> 130 dB	140 dB	
	1 GHz to 16 GHz	> 127 dB	137 dB		> 134 dB	144 dB	
	16 GHz to 20 GHz	> 125 dB	135 dB		> 131 dB	141 dB	
	20 GHz to 30 GHz	> 121 dB	131 dB		> 127 dB	137 dB	
	30 GHz to 40 GHz	> 115 dB	125 dB		> 119 dB	129 dB	
	R&S®ZNA43, 2.4 mm interface						
	40 GHz to 43.5 GHz	> 103 dB	113 dB		> 105 dB	115 dB	
	R&S®ZNA43, 2.92 mm interface						
	40 GHz to 43.5 GHz			113 dB			115 dB
	R&S®ZNA50 and R&S®ZNA67						
	40 GHz to 50 GHz	> 103 dB	113 dB		> 105 dB	115 dB	
R&S®ZNA67							
50 GHz to 67 GHz	> 98 dB	108 dB		> 98 dB	108 dB		

<sup>4</sup> Receiver step attenuator in 0 dB position.

<sup>5</sup> n designates the port number (1/2/3/4).

<sup>6</sup> xx designates the R&S®ZNA model (R&S®ZNA26/R&S®ZNA43/R&S®ZNA50/R&S®ZNA67).



	Base unit + R&S®ZNAxx-B16		Base unit + R&S®ZNAxx-B16 + R&S®ZNAxx-B2n + R&S®ZNAxx-B3n <sup>7</sup>		
	Measured		Measured		
<b>Extended dynamic range at direct source and receiver access input</b>	R&S®ZNA26, R&S®ZNA43				
	10 MHz to 30 MHz	130 dB	119 dB		
	30 MHz to 100 MHz	136 dB	125 dB		
	100 MHz to 500 MHz	136 dB	125 dB		
	Difference between maximum output power and receiver noise floor using the direct receiver access	500 MHz to 1 GHz	145 dB	139 dB	
		1 GHz to 16 GHz	147 dB	144 dB	
		16 GHz to 20 GHz	145 dB	141 dB	
		20 GHz to 30 GHz	141 dB	137 dB	
		30 GHz to 40 GHz	135 dB	129 dB	
	R&S®ZNA43				
	40 GHz to 43.5 GHz	124 dB	116 dB		
	R&S®ZNA50 and R&S®ZNA67				
	40 GHz to 50 GHz	124 dB	116 dB		
	R&S®ZNA67				
	50 GHz to 67 GHz	120 dB	110 dB		

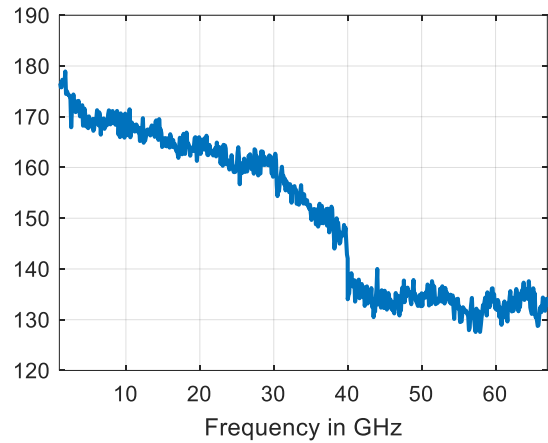
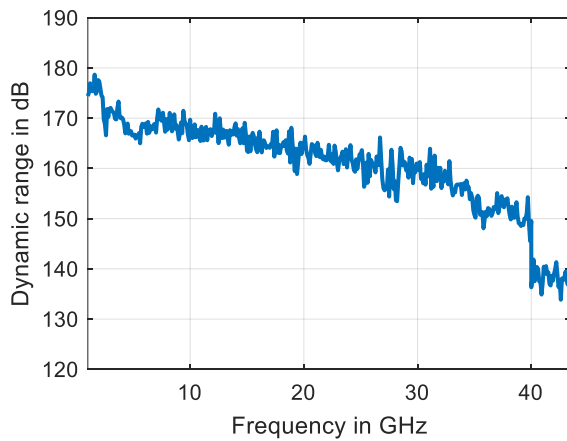

Exemplary measured dynamic range for R&S®ZNA43 (left) and R&S®ZNA67 (right) in reversed coupler configuration (-B16) at maximum output power, receiver step attenuator set to 0 dB at 1 Hz resolution bandwidth

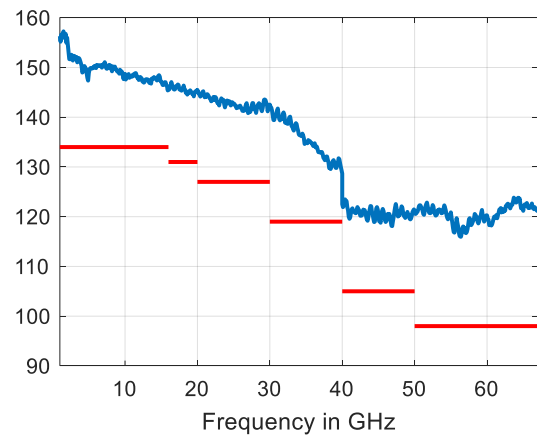
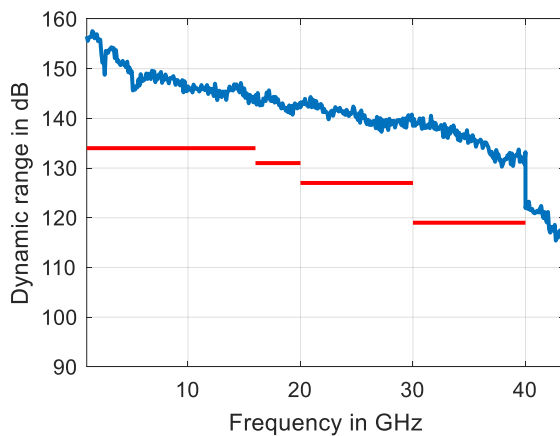

Typical dynamic range in dB versus frequency for R&S®ZNA43 (left) and R&S®ZNA67 (right) <sup>8</sup>

<sup>7</sup> Receiver step attenuator in 0 dB position.

<sup>8</sup> With R&S®ZNAxx-B16, R&S®ZNAxx-B2n and R&S®ZNAxx-B3n options.

## Measurement speed

Measured with firmware version 1.80 and Windows 10 (64 bit).

Measurement time	for 201 measurements points, 10 GHz center frequency, 200 MHz span	
Time per sweep ( $T_{\text{SWEEP}}$ )	1 MHz measurement bandwidth, IF filter (analog) normal	< 2.5 ms
Sweep cycle time ( $T_{\text{CYCLE}}$ )	1 MHz measurement bandwidth, IF filter (analog) normal	< 3.5 ms
Time per sweep point ( $T_{\text{POINT}}$ )	1 MHz measurement bandwidth, IF filter (analog) normal, CW mode	2.5 $\mu\text{s}$
	1 MHz measurement bandwidth, IF filter (analog) wideband, CW mode	1.4 $\mu\text{s}$
	2 MHz measurement bandwidth, IF filter (analog) wideband, CW mode	0.9 $\mu\text{s}$
Acquisition time per point ( $T_{\text{ACQ}}$ )	1 MHz measurement bandwidth, IF filter (analog) wideband	1 $\mu\text{s}$
	30 MHz measurement bandwidth	32 ns

		IEC/ IEEE	VXI11 over 1 Gbit/s LAN	RSIB	USB 2.0
Time for measurement and data transfer (typical)	for 201 measurements points, 800 MHz start frequency, 1 GHz stop frequency, 1 MHz measurement bandwidth <sup>9</sup>	14 ms	13 ms	13 ms	14 ms
Data transfer time (typical)	for 201 measurements points (magnitude)	1.7 ms	0.9 ms	0.6 ms	0.7 ms

Switching time between channels	with a maximum of 2001 points	< 2 ms
Switching time between two preloaded instrument settings	with a maximum of 2001 points	< 2 ms

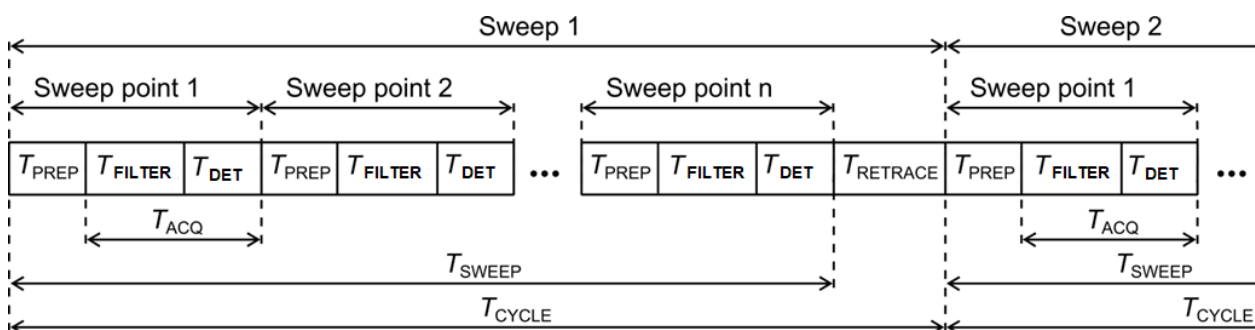

Measurement sequence

$T_{\text{PREP}}$	Preparation time required to set up the internal hardware components
$T_{\text{FILTER}}$	Filter settling time (settling time of the digital filters)
$T_{\text{DET}}$	Detector time (additional time for averaging of detector sample, normally 0)
$T_{\text{ACQ}}$	Data acquisition time ( $T_{\text{ACQ}} = T_{\text{FILTER}} + T_{\text{DET}}$ )
$T_{\text{POINT}}$	Total time for one sweep point
$T_{\text{SWEEP}}$	Time required for one sweep
$T_{\text{RETRACE}}$	Time between two sweeps
$T_{\text{CYCLE}}$	Sweep cycle time ( $T_{\text{CYCLE}} = T_{\text{SWEEP}} + T_{\text{RETRACE}}$ )

<sup>9</sup> In continuous mode, no additional time for data transfer is needed, as data transfer takes place simultaneously with the measurement.

<b>Nominal sweep times in ms versus number of measurement points <sup>10</sup></b>					
<b>Number of measurement points</b>	<b>51</b>	<b>201</b>	<b>401</b>	<b>1601</b>	<b>5001</b>
<b>R&amp;S®ZNA26, R&amp;S®ZNA43, R&amp;S®ZNA50 and R&amp;S®ZNA67</b>					
9 GHz start frequency, 10 GHz stop frequency, 500 kHz measurement bandwidth					
With correction switched off	2.2	5.1	8.9	13.7	27.4
With 2-port TOSM calibration	4.1	9.9	17.3	27.2	54.1
With 4-port TOSM calibration	7.6	19.5	34.6	54.2	107
9 GHz start frequency, 10 GHz stop frequency, 100 kHz measurement bandwidth					
With correction switched off	3.7	7.7	12.8	26.2	63.5
With 2-port TOSM calibration	6.7	14.4	24.9	51.4	126
With 4-port TOSM calibration	12.6	28.4	49.1	103	252
9 GHz start frequency, 10 GHz stop frequency, 1 kHz measurement bandwidth					
With correction switched off	57.7	220	437	1724	5356
With 2-port TOSM calibration	115	440	873	3449	10716
With 4-port TOSM calibration	228	879	1746	6904	21433
<b>R&amp;S®ZNA26</b>					
10 MHz start frequency, 26.5 GHz stop frequency, 500 kHz measurement bandwidth					
With correction switched off	8.7	14.5	19.5	43.6	108
With 2-port TOSM calibration	16.9	28.8	39	87.4	216
With 4-port TOSM calibration	33.2	57.3	78.1	175	434
10 MHz start frequency, 26.5 GHz stop frequency, 100 kHz measurement bandwidth					
With correction switched off	16.8	26.3	33.2	66.1	157
With 2-port TOSM calibration	31.9	51.2	65	131	312
With 4-port TOSM calibration	62	101	129	262	625
10 MHz start frequency, 26.5 GHz stop frequency, 1 kHz measurement bandwidth					
With correction switched off	70.8	239	457	1758	5442
With 2-port TOSM calibration	140	476	913	3517	10889
With 4-port TOSM calibration	278	951	1826	7039	21780
<b>R&amp;S®ZNA43 and R&amp;S®ZNA50</b>					
10 MHz start frequency, 43.5 GHz (50 GHz for R&S®ZNA50) stop frequency, 500 kHz measurement bandwidth					
With correction switched off	10.4	18.3	23.4	47.7	113
With 2-port TOSM calibration	20.4	35.8	46.7	95.5	227
With 4-port TOSM calibration	40.2	71	93.4	191	454
10 MHz start frequency, 43.5 GHz (50 GHz for R&S®ZNA50) stop frequency, 100 kHz measurement bandwidth					
With correction switched off	19.7	30.6	38.8	72.2	162
With 2-port TOSM calibration	37.7	59.9	76.2	143	324
With 4-port TOSM calibration	73.6	118	151	286	648
10 MHz start frequency, 43.5 GHz (50 GHz for R&S®ZNA50) stop frequency, 1 kHz measurement bandwidth					
With correction switched off	73.7	243	463	1764	5449
With 2-port TOSM calibration	146	485	924	3529	10902
With 4-port TOSM calibration	289	969	1848	7064	21806
<b>R&amp;S®ZNA67</b>					
10 MHz start frequency, 67 GHz stop frequency, 500 kHz measurement bandwidth					
With correction switched off	12.5	23.0	29.0	55.3	120
With 2-port TOSM calibration	24.2	45.1	57.1	109	239
With 4-port TOSM calibration	47.5	89.9	115	219	480
10 MHz start frequency, 67 GHz stop frequency, 100 kHz measurement bandwidth					
With correction switched off	22.4	36.3	45.1	82.3	172
With 2-port TOSM calibration	42.7	70.3	87.9	162	341
With 4-port TOSM calibration	83.4	139	175	324	686
10 MHz start frequency, 67 GHz stop frequency, 1 kHz measurement bandwidth					
With correction switched off	73.7	243	463	1764	5449
With 2-port TOSM calibration	146	485	924	3529	10902
With 4-port TOSM calibration	289	969	1848	7064	21806

<sup>10</sup> Sweep time is understood to be the cycle time; static frequency accuracy of the instrument applies; measured with firmware version 1.80, Windows 10 (64 bit).

## Measurement accuracy of the R&S®ZNA26

The data below is valid between +18 °C and +28 °C, provided the temperature has not varied by more than 1 °C after calibration. Validity of the data is conditional on using an R&S®ZN-Z235 calibration kit in order to achieve the effective system data specified below. Frequency points, measurement bandwidth and sweep time have to be identical for measurement and calibration (no interpolation of the calibration). Specifications are based on a matched DUT for transmission measurements and on an isolated DUT for reflection measurements. In both cases, a measurement bandwidth of 10 Hz and a nominal source power of 0 dBm apply for the base unit without options.

Uncertainty of transmission measurements		Magnitude	Phase
10 MHz to 40 MHz	0 dB to -20 dB	0.04 dB	0.5°
	-20 dB to -30 dB	0.23 dB	1.0°
	-30 dB to -40 dB	0.60 dB	3.0°
	-40 dB to -50 dB	1.50 dB	5.0°
	-50 dB to -60 dB	4.50 dB	25.0°
> 40 MHz to 200 MHz	0 dB to -30 dB	0.04 dB	0.5°
	-30 dB to -40 dB	0.05 dB	0.6°
	-40 dB to -50 dB	0.15 dB	0.7°
	-50 dB to -60 dB	0.45 dB	3.0°
> 200 MHz to 10 GHz	0 dB to -30 dB	0.04 dB	0.7°
	-30 dB to -40 dB	0.05 dB	0.8°
	-40 dB to -50 dB	0.05 dB	0.8°
	-50 dB to -60 dB	0.09 dB	1.0°
> 10 GHz to 26.5 GHz	0 dB to -30 dB	0.05 dB	1.3°
	-30 dB to -40 dB	0.06 dB	1.4°
	-40 dB to -50 dB	0.06 dB	1.4°
	-50 dB to -60 dB	0.13 dB	1.5°

Uncertainty of reflection measurements	Logarithmic			Linear	
	Reflection level	Magnitude	Phase	Reflection range	Magnitude
10 MHz to 10 GHz	0 dB	0.10 dB	0.6°	0 dB to -3 dB	0.011
	-3 dB	0.10 dB	0.6°	-3 dB to -6 dB	0.008
	-6 dB	0.11 dB	0.7°	-6 dB to -15 dB	0.006
	-15 dB	0.25 dB	1.7°	-15 dB to -25 dB	0.005
	-25 dB	0.74 dB	5.1°	-25 dB to -35 dB	0.005
	-35 dB	2.16 dB	16.0°	-35 dB	0.005
> 10 GHz to 20 GHz	0 dB	0.13 dB	0.9°	0 dB to -3 dB	0.015
	-3 dB	0.13 dB	0.8°	-3 dB to -6 dB	0.010
	-6 dB	0.14 dB	0.9°	-6 dB to -15 dB	0.008
	-15 dB	0.31 dB	2.1°	-15 dB to -25 dB	0.007
	-25 dB	0.93 dB	6.5°	-25 dB to -35 dB	0.006
	-35 dB	2.64 dB	20.0°	-35 dB	0.006
> 20 GHz to 26.5 GHz	0 dB	0.14 dB	0.9°	0 dB to -3 dB	0.016
	-3 dB	0.14 dB	1.0°	-3 dB to -6 dB	0.012
	-6 dB	0.17 dB	1.1°	-6 dB to -15 dB	0.010
	-15 dB	0.39 dB	2.6°	-15 dB to -25 dB	0.008
	-25 dB	1.15 dB	8.1°	-25 dB to -35 dB	0.008
	-35 dB	3.21 dB	26.0°	-35 dB	0.008

## Measurement accuracy of the R&S®ZNA43, 2.92 mm interface

The data below is valid between +18 °C and +28 °C, provided the temperature has not varied by more than 1 °C after calibration. Validity of the data is conditional on using an R&S®ZN-Z229 calibration kit in order to achieve the effective system data specified below. Frequency points, measurement bandwidth and sweep time have to be identical for measurement and calibration (no interpolation of the calibration). Specifications are based on a matched DUT for transmission measurements and on an isolated DUT for reflection measurements. In both cases, a measurement bandwidth of 10 Hz and a nominal source power of 0 dBm apply for the base unit without options.

Uncertainty of transmission measurements		Magnitude	Phase
10 MHz to 40 MHz	0 dB to –20 dB	0.04 dB	0.5°
	–20 dB to –30 dB	0.23 dB	1.0°
	–30 dB to –40 dB	0.60 dB	3.0°
	–40 dB to –50 dB	1.50 dB	5.0°
	–50 dB to –60 dB	4.50 dB	25.0°
> 40 MHz to 200 MHz	0 dB to –30 dB	0.04 dB	0.5°
	–30 dB to –40 dB	0.05 dB	0.6°
	–40 dB to –50 dB	0.15 dB	0.7°
	–50 dB to –60 dB	0.45 dB	3.0°
> 200 MHz to 10 GHz	0 dB to –30 dB	0.04 dB	0.7°
	–30 dB to –40 dB	0.05 dB	0.8°
	–40 dB to –50 dB	0.05 dB	0.8°
	–50 dB to –60 dB	0.09 dB	1.0°
> 10 GHz to 26.5 GHz	0 dB to –30 dB	0.05 dB	1.3°
	–30 dB to –40 dB	0.06 dB	1.4°
	–40 dB to –50 dB	0.06 dB	1.4°
	–50 dB to –60 dB	0.13 dB	1.5°
> 26.5 GHz to 40 GHz	0 dB to –30 dB	0.06 dB	1.8°
	–30 dB to –40 dB	0.07 dB	2.0°
	–40 dB to –50 dB	0.07 dB	2.0°
	–50 dB to –60 dB	0.19 dB	2.0°
> 40 GHz to 43.5 GHz (meas.)	0 dB to –30 dB	0.07 dB	2.0°
	–30 dB to –40 dB	0.08 dB	2.2°
	–40 dB to –50 dB	0.15 dB	2.2°
	–50 dB to –60 dB	0.47 dB	3.9°

Uncertainty of reflection measurements	Logarithmic			Linear	
	Reflection level	Magnitude	Phase	Reflection range	Magnitude
10 MHz to 10 GHz	0 dB	0.11 dB	0.8°	0 dB to –3 dB	0.013
	–3 dB	0.11 dB	0.7°	–3 dB to –6 dB	0.009
	–6 dB	0.12 dB	0.8°	–6 dB to –15 dB	0.007
	–15 dB	0.28 dB	1.9°	–15 dB to –25 dB	0.006
	–25 dB	0.83 dB	5.7°	–25 dB to –35 dB	0.006
> 10 GHz to 26.5 GHz	–35 dB	2.39 dB	18.0°	–35 dB	0.006
	0 dB	0.14 dB	0.9°	0 dB to –3 dB	0.016
	–3 dB	0.14 dB	1.0°	–3 dB to –6 dB	0.012
	–6 dB	0.17 dB	1.1°	–6 dB to –15 dB	0.010
	–15 dB	0.39 dB	2.6°	–15 dB to –25 dB	0.008
> 26.5 GHz to 40 GHz	–25 dB	1.15 dB	8.1°	–25 dB to –35 dB	0.008
	–35 dB	3.21 dB	26.0°	–35 dB	0.008
	0 dB	0.22 dB	1.4°	0 dB to –3 dB	0.025
	–3 dB	0.22 dB	1.5°	–3 dB to –6 dB	0.018
	–6 dB	0.26 dB	1.7°	–6 dB to –15 dB	0.015
> 40 GHz to 43.5 GHz (meas.)	–15 dB	0.61 dB	4.1°	–15 dB to –25 dB	0.013
	–25 dB	1.76 dB	13.0°	–25 dB to –35 dB	0.013
	–35 dB	4.65 dB	41.0°	–35 dB	0.013
	0 dB	0.22 dB	1.5°	0 dB to –3 dB	0.026
	–3 dB	0.23 dB	1.5°	–3 dB to –6 dB	0.019
> 40 GHz to 43.5 GHz (meas.)	–6 dB	0.26 dB	1.8°	–6 dB to –15 dB	0.015
	–15 dB	0.61 dB	4.2°	–15 dB to –25 dB	0.013
	–25 dB	1.76 dB	13.0°	–25 dB to –35 dB	0.013
	–35 dB	4.65 dB	41.0°	–35 dB	0.013

## Measurement accuracy of the R&S®ZNA43, 2.4 mm interface

The data below is valid between +18 °C and +28 °C, provided the temperature has not varied by more than 1 °C after calibration. Validity of the data is conditional on using an R&S®ZV-Z224 calibration kit with accredited calibration in order to achieve the effective system data specified below. Frequency points, measurement bandwidth and sweep time have to be identical for measurement and calibration (no interpolation of the calibration). Specifications are based on a matched DUT for transmission measurements and on an isolated DUT for reflection measurements. In both cases, a measurement bandwidth of 10 Hz and a nominal source power of 0 dBm apply for the base unit without options.

Uncertainty of transmission measurements		Magnitude	Phase
10 MHz to 40 MHz	0 dB to -20 dB	0.04 dB	0.5°
	-20 dB to -30 dB	0.23 dB	1.0°
	-30 dB to -40 dB	0.60 dB	3.0°
	-40 dB to -50 dB	1.50 dB	5.0°
	-50 dB to -60 dB	4.50 dB	25.0°
> 40 MHz to 200 MHz	0 dB to -30 dB	0.04 dB	0.5°
	-30 dB to -40 dB	0.05 dB	0.6°
	-40 dB to -50 dB	0.15 dB	0.7°
	-50 dB to -60 dB	0.45 dB	3.0°
> 200 MHz to 10 GHz	0 dB to -30 dB	0.04 dB	0.7°
	-30 dB to -40 dB	0.05 dB	0.8°
	-40 dB to -50 dB	0.05 dB	0.8°
	-50 dB to -60 dB	0.09 dB	1.0°
> 10 GHz to 20 GHz	0 dB to -30 dB	0.05 dB	1.3°
	-30 dB to -40 dB	0.06 dB	1.4°
	-40 dB to -50 dB	0.06 dB	1.4°
	-50 dB to -60 dB	0.13 dB	1.5°
> 20 GHz to 40 GHz	0 dB to -30 dB	0.06 dB	1.8°
	-30 dB to -40 dB	0.07 dB	2.0°
	-40 dB to -50 dB	0.07 dB	2.0°
	-50 dB to -60 dB	0.19 dB	2.0°
> 40 GHz to 43.5 GHz	0 dB to -30 dB	0.07 dB	2.0°
	-30 dB to -40 dB	0.08 dB	2.2°
	-40 dB to -50 dB	0.15 dB	2.2°
	-50 dB to -60 dB	0.47 dB	3.9°

Uncertainty of reflection measurements	Logarithmic			Linear	
	Reflection level	Magnitude	Phase	Reflection range	Magnitude
10 MHz to 10 GHz	0 dB	0.10 dB	0.6°	0 dB to -3 dB	0.011
	-3 dB	0.10 dB	0.6°	-3 dB to -6 dB	0.008
	-6 dB	0.11 dB	0.7°	-6 dB to -15 dB	0.006
	-15 dB	0.25 dB	1.7°	-15 dB to -25 dB	0.005
	-25 dB	0.74 dB	5.1°	-25 dB to -35 dB	0.005
	-35 dB	2.16 dB	16.0°	-35 dB	0.005
> 10 GHz to 20 GHz	0 dB	0.13 dB	0.9°	0 dB to -3 dB	0.015
	-3 dB	0.13 dB	0.8°	-3 dB to -6 dB	0.010
	-6 dB	0.14 dB	0.9°	-6 dB to -15 dB	0.008
	-15 dB	0.31 dB	2.1°	-15 dB to -25 dB	0.007
	-25 dB	0.93 dB	6.5°	-25 dB to -35 dB	0.006
	-35 dB	2.64 dB	20.0°	-35 dB	0.006
> 20 GHz to 40 GHz	0 dB	0.16 dB	1.2°	0 dB to -3 dB	0.019
	-3 dB	0.16 dB	1.2°	-3 dB to -6 dB	0.013
	-6 dB	0.17 dB	1.3°	-6 dB to -15 dB	0.010
	-15 dB	0.39 dB	2.6°	-15 dB to -25 dB	0.008
	-25 dB	1.15 dB	8.1°	-25 dB to -35 dB	0.008
	-35 dB	3.21 dB	26.0°	-35 dB	0.008
> 40 GHz to 43.5 GHz	0 dB	0.20 dB	1.6°	0 dB to -3 dB	0.024
	-3 dB	0.20 dB	1.6°	-3 dB to -6 dB	0.016
	-6 dB	0.22 dB	1.7°	-6 dB to -15 dB	0.013
	-15 dB	0.49 dB	3.3°	-15 dB to -25 dB	0.010
	-25 dB	1.43 dB	10.0°	-25 dB to -35 dB	0.010
	-35 dB	3.88 dB	32.0°	-35 dB	0.010

## Measurement accuracy of the R&S®ZNA50

The data below is valid between +18 °C and +28 °C, provided the temperature has not varied by more than 1 °C after calibration. Validity of the data is conditional on using an R&S®ZN-Z224 calibration kit in order to achieve the effective system data specified below. Frequency points, measurement bandwidth and sweep time have to be identical for measurement and calibration (no interpolation of the calibration). Specifications are based on a matched DUT for transmission measurements and on an isolated DUT for reflection measurements. In both cases, a measurement bandwidth of 10 Hz and a nominal source power of 0 dBm apply for the base unit without options.

Uncertainty of transmission measurements		Magnitude	Phase
10 MHz to 40 MHz	0 dB to -20 dB	0.04 dB	0.5°
	-20 dB to -30 dB	0.23 dB	1.0°
	-30 dB to -40 dB	0.60 dB	3.0°
	-40 dB to -50 dB	1.50 dB	5.0°
	-50 dB to -60 dB	4.50 dB	25.0°
> 40 MHz to 200 MHz	0 dB to -30 dB	0.04 dB	0.5°
	-30 dB to -40 dB	0.05 dB	0.6°
	-40 dB to -50 dB	0.15 dB	0.7°
	-50 dB to -60 dB	0.45 dB	3.0°
> 200 MHz to 10 GHz	0 dB to -30 dB	0.04 dB	0.7°
	-30 dB to -40 dB	0.05 dB	0.8°
	-40 dB to -50 dB	0.05 dB	0.8°
	-50 dB to -60 dB	0.09 dB	1.0°
> 10 GHz to 26.5 GHz	0 dB to -30 dB	0.05 dB	1.3°
	-30 dB to -40 dB	0.06 dB	1.4°
	-40 dB to -50 dB	0.06 dB	1.4°
	-50 dB to -60 dB	0.13 dB	1.5°
> 26.5 GHz to 40 GHz	0 dB to -30 dB	0.06 dB	1.8°
	-30 dB to -40 dB	0.07 dB	2.0°
	-40 dB to -50 dB	0.07 dB	2.0°
	-50 dB to -60 dB	0.19 dB	2.0°
> 40 GHz to 50 GHz	0 dB to -30 dB	0.07 dB	2.0°
	-30 dB to -40 dB	0.08 dB	2.2°
	-40 dB to -50 dB	0.17 dB	2.2°
	-50 dB to -60 dB	0.47 dB	3.6°

Uncertainty of reflection measurements	Logarithmic			Linear	
	Reflection level	Magnitude	Phase	Reflection range	Magnitude
0.01 GHz to 10 GHz	0 dB	0.10 dB	0.6°	0 dB to -3 dB	0.011
	-3 dB	0.10 dB	0.6°	-3 dB to -6 dB	0.008
	-6 dB	0.11 dB	0.7°	-6 dB to -15 dB	0.006
	-15 dB	0.25 dB	1.7°	-15 dB to -25 dB	0.005
	-25 dB	0.74 dB	5.1°	-25 dB to -35 dB	0.005
> 10 GHz to 20 GHz	-35 dB	2.16 dB	16.0°	-35 dB	0.005
	0 dB	0.13 dB	0.9°	0 dB to -3 dB	0.015
	-3 dB	0.13 dB	0.8°	-3 dB to -6 dB	0.010
	-6 dB	0.14 dB	0.9°	-6 dB to -15 dB	0.008
	-15 dB	0.31 dB	2.1°	-15 dB to -25 dB	0.007
> 20 GHz to 40 GHz	-25 dB	0.93 dB	6.5°	-25 dB to -35 dB	0.006
	-35 dB	2.64 dB	20.0°	-35 dB	0.006
	0 dB	0.17 dB	1.2°	0 dB to -3 dB	0.019
	-3 dB	0.16 dB	1.2°	-3 dB to -6 dB	0.013
	-6 dB	0.18 dB	1.3°	-6 dB to -15 dB	0.011
> 40 GHz to 50 GHz	-15 dB	0.39 dB	2.7°	-15 dB to -25 dB	0.008
	-25 dB	1.15 dB	8.1°	-25 dB to -35 dB	0.008
	-35 dB	3.21 dB	26.0°	-35 dB	0.008
	0 dB	0.20 dB	1.6°	0 dB to -3 dB	0.024
	-3 dB	0.20 dB	1.6°	-3 dB to -6 dB	0.016
	-6 dB	0.22 dB	1.7°	-6 dB to -15 dB	0.013
	-15 dB	0.49 dB	3.3°	-15 dB to -25 dB	0.010
	-25 dB	1.43 dB	10.0°	-25 dB to -35 dB	0.010
	-35 dB	3.88 dB	32.0°	-35 dB	0.010

## Measurement accuracy of the R&S®ZNA67

The data below is valid between +18 °C and +28 °C, provided the temperature has not varied by more than 1 °C after calibration. Validity of the data is conditional on using an R&S®ZN-Z218 calibration kit in order to achieve the effective system data specified below. Frequency points, measurement bandwidth and sweep time have to be identical for measurement and calibration (no interpolation of the calibration). Specifications are based on a matched DUT for transmission measurements and on an isolated DUT for reflection measurements. In both cases, a measurement bandwidth of 10 Hz and a nominal source power of 0 dBm apply for the base unit without options.

Uncertainty of transmission measurements		Magnitude	Phase
10 MHz to 40 MHz	0 dB to -20 dB	0.04 dB	0.5°
	-20 dB to -30 dB	0.23 dB	1.0°
	-30 dB to -40 dB	0.60 dB	3.0°
	-40 dB to -50 dB	1.50 dB	5.0°
	-50 dB to -60 dB	4.50 dB	25.0°
> 40 MHz to 200 MHz	0 dB to -30 dB	0.04 dB	0.5°
	-30 dB to -40 dB	0.05 dB	0.6°
	-40 dB to -50 dB	0.15 dB	0.7°
	-50 dB to -60 dB	0.45 dB	3.0°
> 200 MHz to 10 GHz	0 dB to -30 dB	0.04 dB	0.7°
	-30 dB to -40 dB	0.05 dB	0.8°
	-40 dB to -50 dB	0.05 dB	0.8°
	-50 dB to -60 dB	0.09 dB	1.0°
> 10 GHz to 26.5 GHz	0 dB to -30 dB	0.05 dB	1.3°
	-30 dB to -40 dB	0.06 dB	1.4°
	-40 dB to -50 dB	0.06 dB	1.4°
	-50 dB to -60 dB	0.13 dB	1.5°
> 26.5 GHz to 40 GHz	0 dB to -30 dB	0.06 dB	1.8°
	-30 dB to -40 dB	0.07 dB	2.0°
	-40 dB to -50 dB	0.07 dB	2.0°
	-50 dB to -60 dB	0.19 dB	2.0°
> 40 GHz to 50 GHz	0 dB to -30 dB	0.07 dB	2.0°
	-30 dB to -40 dB	0.08 dB	2.2°
	-40 dB to -50 dB	0.17 dB	2.2°
	-50 dB to -60 dB	0.47 dB	3.6°
> 50 GHz to 67 GHz	0 dB to -30 dB	0.07 dB	2.1°
	-30 dB to -40 dB	0.08 dB	2.3°
	-40 dB to -50 dB	0.18 dB	2.8°
	-50 dB to -60 dB	0.47 dB	4.3°



Uncertainty of reflection measurements	Logarithmic			Linear	
	Reflection level	Magnitude	Phase	Reflection range	Magnitude
0.01 GHz to 10 GHz	0 dB	0.10 dB	0.6°	0 dB to -3 dB	0.011
	-3 dB	0.10 dB	0.6°	-3 dB to -6 dB	0.008
	-6 dB	0.11 dB	0.7°	-6 dB to -15 dB	0.006
	-15 dB	0.25 dB	1.7°	-15 dB to -25 dB	0.005
	-25 dB	0.74 dB	5.1°	-25 dB to -35 dB	0.005
> 10 GHz to 20 GHz	-35 dB	2.16 dB	16.0°	-35 dB	0.005
	0 dB	0.13 dB	0.9°	0 dB to -3 dB	0.015
	-3 dB	0.13 dB	0.8°	-3 dB to -6 dB	0.010
	-6 dB	0.14 dB	0.9°	-6 dB to -15 dB	0.008
	-15 dB	0.31 dB	2.1°	-15 dB to -25 dB	0.007
> 20 GHz to 40 GHz	-25 dB	0.93 dB	6.5°	-25 dB to -35 dB	0.006
	-35 dB	2.64 dB	20.0°	-35 dB	0.006
	0 dB	0.16 dB	1.2°	0 dB to -3 dB	0.019
	-3 dB	0.16 dB	1.2°	-3 dB to -6 dB	0.013
	-6 dB	0.17 dB	1.3°	-6 dB to -15 dB	0.010
> 40 GHz to 50 GHz	-15 dB	0.39 dB	2.6°	-15 dB to -25 dB	0.008
	-25 dB	1.15 dB	8.1°	-25 dB to -35 dB	0.008
	-35 dB	3.21 dB	26.0°	-35 dB	0.008
	0 dB	0.20 dB	1.6°	0 dB to -3 dB	0.024
	-3 dB	0.20 dB	1.6°	-3 dB to -6 dB	0.016
> 50 GHz to 67 GHz	-6 dB	0.22 dB	1.7°	-6 dB to -15 dB	0.013
	-15 dB	0.49 dB	3.3°	-15 dB to -25 dB	0.010
	-25 dB	1.43 dB	10.0°	-25 dB to -35 dB	0.010
	-35 dB	3.88 dB	32.0°	-35 dB	0.010
	0 dB	0.26 dB	1.8°	0 dB to -3 dB	0.031
> 67 GHz to 100 GHz	-3 dB	0.26 dB	1.8°	-3 dB to -6 dB	0.022
	-6 dB	0.30 dB	2.0°	-6 dB to -15 dB	0.018
	-15 dB	0.68 dB	4.7°	-15 dB to -25 dB	0.015
	-25 dB	1.95 dB	14.0°	-25 dB to -35 dB	0.014
	-35 dB	5.08 dB	46.0°	-35 dB	0.014

## Reflection measurement accuracy of the R&S®ZNA26 and R&S®ZNA43

The diagrams below show the typical uncertainty of the reflection magnitude and reflection phase measurements for the R&S®ZNA26 in the frequency range from 10 MHz to 26.5 GHz and for the R&S®ZNA43 in the frequency range from 10 MHz to 43.5 GHz. Analysis conditions:  $S_{12} = S_{21} = 0$ , calibration power: 0 dBm, measurement power: 0 dBm. Drift effects were not considered.

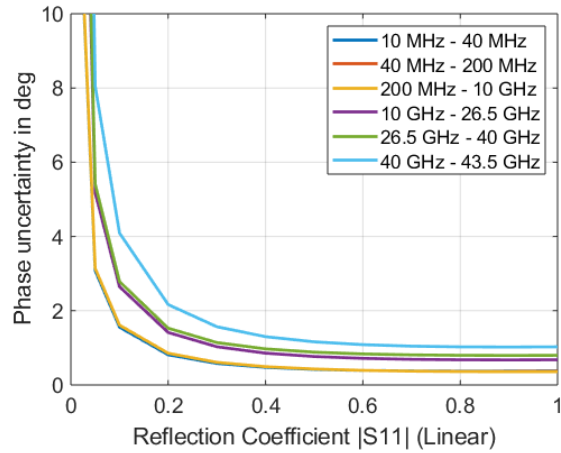
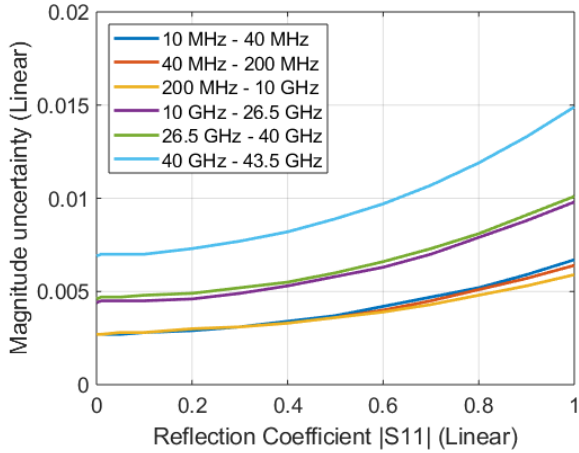

## Transmission measurement accuracy of the R&S®ZNA26 and R&S®ZNA43

The diagrams below show the typical uncertainty of the transmission magnitude and transmission phase measurements for the R&S®ZNA26 in the frequency range from 10 MHz to 26.5 GHz and for the R&S®ZNA43 in the frequency range from 10 MHz to 43.5 GHz. Analysis conditions:  $S_{11} = S_{22} = 0$ , calibration power: 0 dBm, measurement power: 0 dBm, high-quality cable. Drift effects were not considered.

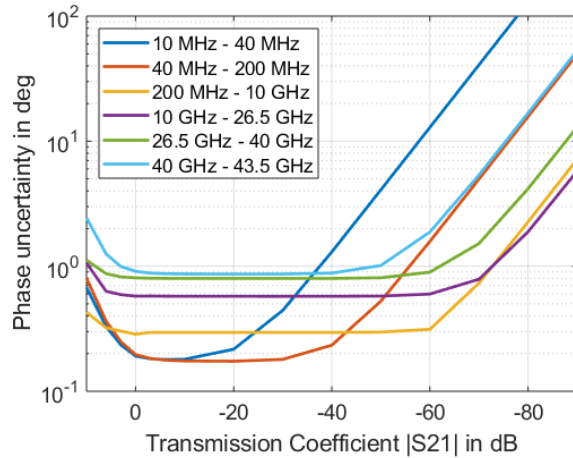
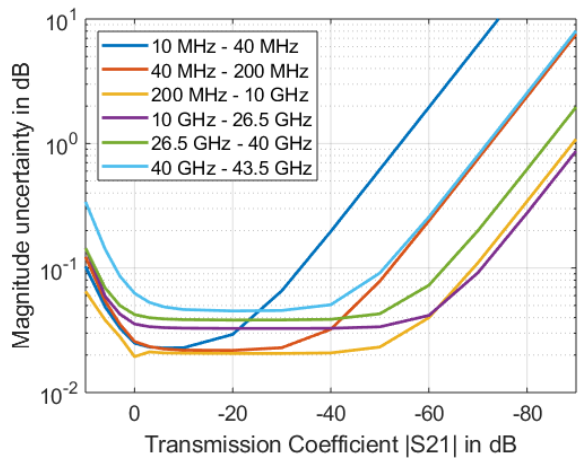

## Reflection measurement accuracy of the R&S®ZNA50 and R&S®ZNA67

The diagrams below show the typical uncertainty of the reflection magnitude and reflection phase measurements for the R&S®ZNA50 in the frequency range from 10 MHz to 50 GHz and for the R&S®ZNA67 in the frequency range from 10 MHz to 67 GHz. Analysis conditions:  $S_{12} = S_{21} = 0$ , calibration power: 0 dBm, measurement power: 0 dBm. Drift effects were not considered.

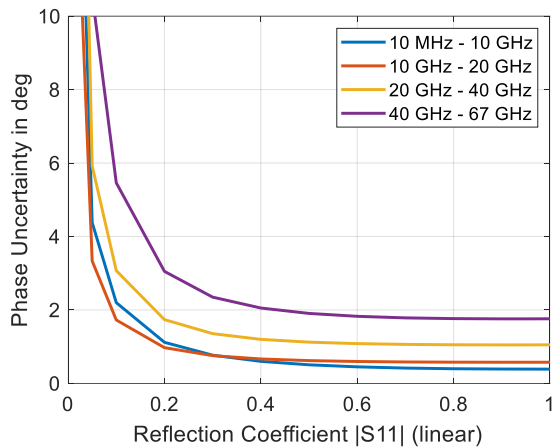
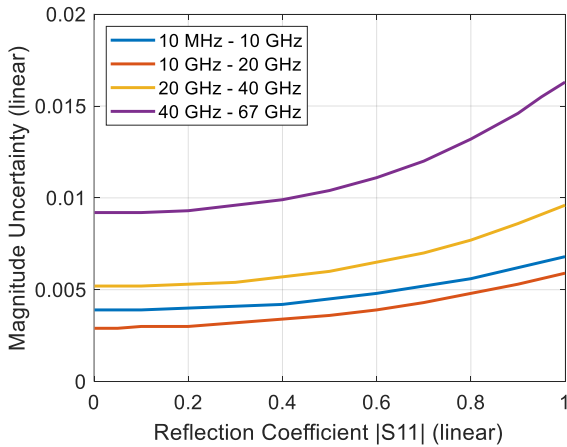

## Transmission measurement accuracy of the R&S®ZNA50 and R&S®ZNA67

The diagrams below show the typical uncertainty of the transmission magnitude and transmission phase measurements for the R&S®ZNA50 in the frequency range from 10 MHz to 50 GHz and for the R&S®ZNA67 in the frequency range from 10 MHz to 67 GHz. Analysis conditions:  $S_{11} = S_{22} = 0$ , calibration power: 0 dBm, measurement power: 0 dBm, high-quality cable. Drift effects were not considered.

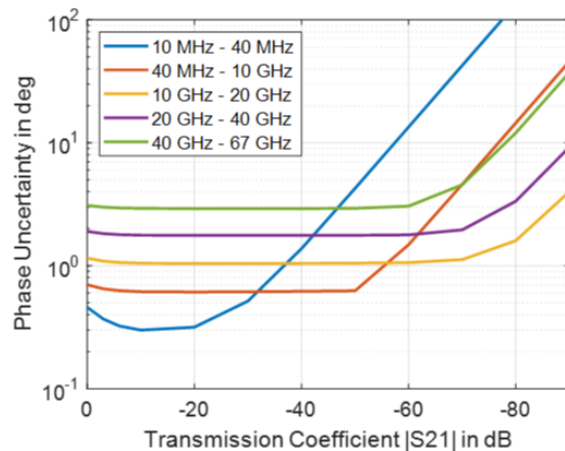
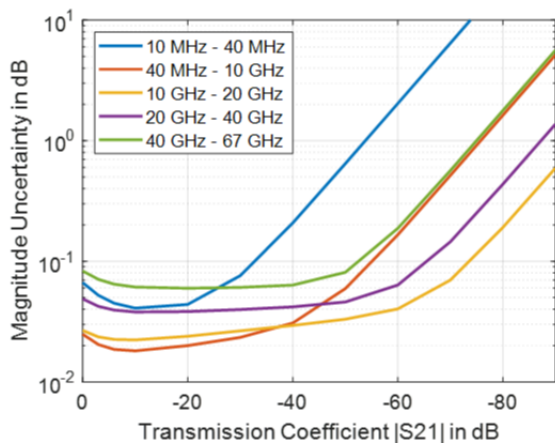

## Effective system data

The data below is valid between +18 °C and +28 °C, provided the temperature has not varied by more than 1 °C after calibration. Frequency points, measurement bandwidth and sweep time have to be identical for measurement and calibration (no interpolation of the calibration). The data is based on a measurement bandwidth of 10 Hz.

R&S®ZNA26, calibrated with R&S®ZN-Z235 calibration kit	10 MHz to 10 GHz		10 GHz to 20 GHz		20 GHz to 26.5 GHz	
	Specifi- cation	Typical	Specifi- cation	Typical	Specifi- cation	Typical
Directivity in dB	46	49	44	47	42	45
Source match in dB	43	46	40	43	40	43
Load match in dB	45	48	43	46	41	44
Reflection tracking in dB	0.03	0.02	0.04	0.03	0.04	0.03
Transmission tracking in dB	0.02	0.01	0.03	0.02	0.03	0.02

R&S®ZNA43, 2.92 mm interface calibrated with R&S®ZN-Z229 calibration kit	10 MHz to 10 GHz		10 GHz to 26.5 GHz		26.5 GHz to 40 GHz		40 GHz to 43.5 GHz	
	Specifi- cation	Typical	Specifi- cation	Typical	Specifi- cation	Typical	Measured	
Directivity in dB	45	48	42	45	38	41	38	
Source match in dB	41	44	40	43	36	39	36	
Load match in dB	44	47	41	44	37	40	37	
Reflection tracking in dB	0.03	0.02	0.04	0.03	0.04	0.03	0.06	
Transmission tracking in dB	0.02	0.01	0.03	0.02	0.04	0.03	0.05	

R&S®ZNA43, 2.4 mm interface calibrated with R&S®ZN-Z224 calibration kit	10 MHz to 10 GHz		10 GHz to 20 GHz		20 GHz to 40 GHz		40 GHz to 43.5 GHz	
	Specifi- cation	Typical	Specifi- cation	Typical	Specifi- cation	Typical	Specifi- cation	Typical
Directivity in dB	46	49	44	47	42	45	40	43
Source match in dB	43	46	40	43	38	41	36	39
Load match in dB	45	48	43	46	41	44	39	42
Reflection tracking in dB	0.03	0.02	0.04	0.03	0.04	0.03	0.06	0.05
Transmission tracking in dB	0.02	0.01	0.03	0.02	0.04	0.03	0.05	0.04

R&S®ZNA50, calibrated with R&S®ZN-Z224 calibration kit	10 MHz to 10 GHz		10 GHz to 20 GHz		20 GHz to 40 GHz		40 GHz to 50 GHz	
	Specifi- cation	Typical	Specifi- cation	Typical	Specifi- cation	Typical	Specifi- cation	Typical
Directivity in dB	46	49	44	47	42	45	40	43
Source match in dB	43	46	40	43	38	41	36	39
Load match in dB	45	48	43	46	41	44	39	42
Reflection tracking in dB	0.03	0.02	0.04	0.03	0.04	0.03	0.06	0.05
Transmission tracking in dB	0.02	0.01	0.03	0.02	0.04	0.03	0.06	0.05

R&S®ZNA67, calibrated with R&S®ZN-Z218 calibration kit	10 MHz to 10 GHz		10 GHz to 20 GHz		20 GHz to 40 GHz		40 GHz to 50 GHz		50 GHz to 67 GHz	
	Specifi- cation	Typical	Specifi- cation	Typical	Specifi- cation	Typical	Specifi- cation	Typical	Specifi- cation	Typical
Directivity in dB	46	49	44	47	42	45	40	43	37	40
Source match in dB	43	46	40	43	38	41	36	39	34	37
Load match in dB	45	48	43	46	41	44	39	42	36	39
Reflection tracking in dB	0.03	0.02	0.04	0.03	0.04	0.03	0.06	0.05	0.07	0.06
Transmission tracking in dB	0.02	0.01	0.03	0.02	0.04	0.03	0.06	0.05	0.06	0.05

## Uncorrected system data

The data below is valid between +18 °C and +28 °C. It is based on a source power of –10 dBm and a measurement bandwidth of 1 kHz.

	Specification	Typical	Measured
Directivity in dB	R&S®ZNA26, R&S®ZNA43, R&S®ZNA50 and R&S®ZNA67		
	10 MHz to 20 MHz	> 8 dB	12 dB
	20 MHz to 20 GHz	> 10 dB	18 dB
	20 GHz to 35 GHz	> 8 dB	15 dB
	35 GHz to 40 GHz	> 6 dB	10 dB
	R&S®ZNA43, 2.4 mm interface		
	40 GHz to 43.5 GHz	> 6 dB	10 dB
	R&S®ZNA43, 2.92 mm interface		
	40 GHz to 43.5 GHz		10 dB
	R&S®ZNA50 and R&S®ZNA67		
40 GHz to 67 GHz	> 6 dB	10 dB	
Source match in dB	R&S®ZNA26, R&S®ZNA43, R&S®ZNA50 and R&S®ZNA67		
	10 MHz to 20 GHz	> 10 dB	18 dB
	20 GHz to 35 GHz	> 8 dB	15 dB
	35 GHz to 40 GHz	> 6 dB	10 dB
	R&S®ZNA43, 2.4 mm interface		
	40 GHz to 43.5 GHz	> 6 dB	10 dB
	R&S®ZNA43, 2.92 mm interface		
	40 GHz to 43.5 GHz		10 dB
	R&S®ZNA50 and R&S®ZNA67		
	40 GHz to 67 GHz	> 6 dB	10 dB
Reflection tracking in dB	R&S®ZNA26, R&S®ZNA43, R&S®ZNA50 and R&S®ZNA67		
	10 MHz to 10 GHz	< 1.5 dB	0.5 dB
	10 GHz to 26.5 GHz	< 2 dB	0.5 dB
	26.5 GHz to 40 GHz	< 2.5 dB	0.5 dB
	R&S®ZNA43, 2.4 mm interface		
	40 GHz to 43.5 GHz	< 3 dB	1 dB
	R&S®ZNA43, 2.92 mm interface		
	40 GHz to 43.5 GHz		1 dB
	R&S®ZNA50 and R&S®ZNA67		
	40 GHz to 50 GHz	< 3 dB	1 dB
Transmission tracking in dB	R&S®ZNA26, R&S®ZNA43, R&S®ZNA50 and R&S®ZNA67		
	10 MHz to 10 GHz	< 1.5 dB	0.5 dB
	10 GHz to 26.5 GHz	< 2 dB	0.5 dB
	26.5 GHz to 40 GHz	< 2.5 dB	0.5 dB
	R&S®ZNA43, 2.4 mm interface		
	40 GHz to 43.5 GHz	< 3 dB	1 dB
	R&S®ZNA43, 2.92 mm interface		
	40 GHz to 43.5 GHz		1 dB
	R&S®ZNA50 and R&S®ZNA67		
	40 GHz to 50 GHz	< 3 dB	1 dB
Load match in dB	R&S®ZNA26, R&S®ZNA43, R&S®ZNA50 and R&S®ZNA67		
	10 MHz to 20 GHz	> 10 dB	18 dB
	R&S®ZNA26, R&S®ZNA43 and R&S®ZNA67		
	20 GHz to 40 GHz	> 8 dB	15 dB
	R&S®ZNA50		
	20 GHz to 40 GHz	> 6 dB	13 dB
	R&S®ZNA43, 2.4 mm interface		
	40 GHz to 43.5 GHz	> 6 dB	10 dB
	R&S®ZNA43, 2.92 mm interface		
	40 GHz to 43.5 GHz		10 dB
R&S®ZNA50 and R&S®ZNA67			
40 GHz to 67 GHz	> 6 dB	10 dB	

Trace stability		1 kHz IF bandwidth	100 kHz IF bandwidth		
		Measured	Specification	Typical	Measured
Trace noise magnitude (RMS) at 0 dBm source power, 0 dB reflection	R&S®ZNA26, R&S®ZNA43, R&S®ZNA50 and R&S®ZNA67				
	10 MHz to 20 MHz	0.010 dB	< 0.500 dB	0.100 dB	
	20 MHz to 50 MHz	0.005 dB	< 0.200 dB	0.050 dB	
	50 MHz to 150 MHz	0.001 dB	< 0.050 dB	0.010 dB	
	150 MHz to 500 MHz	0.001 dB	< 0.020 dB	0.002 dB	
	500 MHz to 20 GHz	0.001 dB	< 0.005 dB	0.002 dB	
	20 GHz to 40 GHz	0.001 dB	< 0.008 dB	0.003 dB	
	R&S®ZNA43, 2.4 mm interface				
	40 GHz to 43.5 GHz	0.001 dB	< 0.030 dB	0.007 dB	
	R&S®ZNA43, 2.92 mm interface				
	40 GHz to 43.5 GHz	0.001 dB			0.007 dB
	R&S®ZNA50 and R&S®ZNA67				
	40 GHz to 50 GHz		< 0.030 dB	0.007 dB	
	R&S®ZNA67				
50 GHz to 67 GHz		< 0.040 dB	0.010 dB		
Trace noise phase (RMS) at 0 dBm source power, 0 dB reflection	R&S®ZNA26, R&S®ZNA43, R&S®ZNA50 and R&S®ZNA67				
	10 MHz to 20 MHz	0.05°	< 3.00°	0.5°	
	20 MHz to 50 MHz	0.020°	< 1.00°	0.20°	
	50 MHz to 150 MHz	0.005°	< 0.30°	0.05°	
	150 MHz to 500 MHz	0.002°	< 0.10°	0.02°	
	500 MHz to 20 GHz	0.001°	< 0.04°	0.01°	
	20 GHz to 40 GHz	0.002°	< 0.06°	0.02°	
	R&S®ZNA43, 2.4 mm interface				
	40 GHz to 43.5 GHz	0.006°	< 0.20°	0.06°	
	R&S®ZNA43, 2.92 mm interface				
	40 GHz to 43.5 GHz				0.06°
	R&S®ZNA50 and R&S®ZNA67				
	40 GHz to 50 GHz	0.006°	< 0.20°	0.06°	
	R&S®ZNA67				
50 GHz to 67 GHz	0.006°	< 0.25°	0.12°		
Temperature dependence at 0 dB transmission or reflection	10 MHz to 5 GHz			0.01 dB/K, 0.1°/K	
	5 GHz to 40 GHz			0.02 dB/K, 0.4°/K	
	40 GHz to 67 GHz			0.04 dB/K, 0.8°/K	

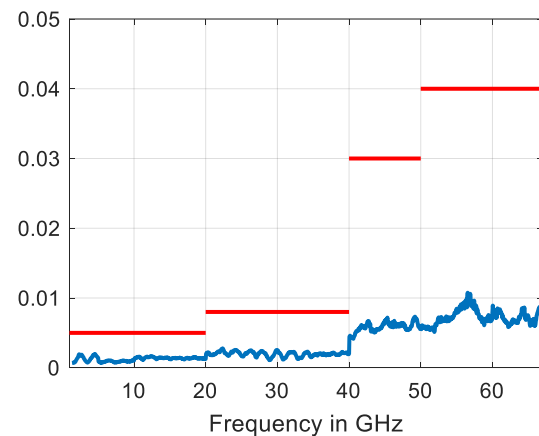
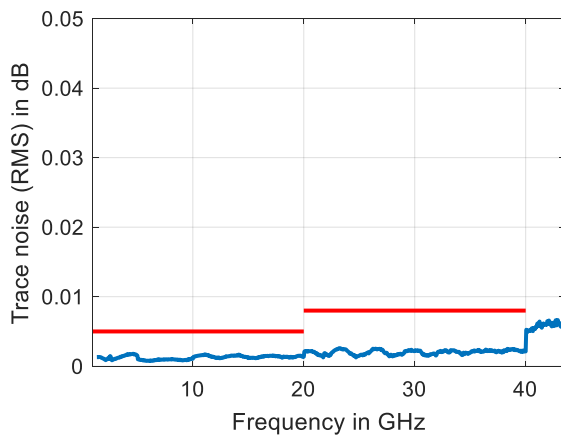

Typical trace noise magnitude in dB (RMS) versus frequency for R&S®ZNA43 (left) and R&S®ZNA67 (right) <sup>11</sup>

<sup>11</sup> At 0 dBm source power, 0 dB reflection and 100 kHz bandwidth.

## Test port output

The data below is valid from +18 °C to +28 °C.

		Specification	Typical	Measured
Power range without optional source step attenuator (for data with additional source step attenuator(s) refer to "Options")	R&S®ZNA26			
	10 MHz to 4 GHz	-80 dBm to +17 dBm	up to +20 dBm	
	4 GHz to 20 GHz	-80 dBm to +13 dBm	up to +18 dBm	
	20 GHz to 25 GHz	-80 dBm to +11 dBm	up to +15 dBm	
	25 GHz to 26.5 GHz	-80 dBm to +8 dBm	up to +11 dBm	
	R&S®ZNA43			
	10 MHz to 4 GHz	-80 dBm to +17 dBm	up to +20 dBm	
	4 GHz to 20 GHz	-80 dBm to +13 dBm	up to +16 dBm	
	20 GHz to 25 GHz	-80 dBm to +12 dBm	up to +15 dBm	
	25 GHz to 30 GHz	-80 dBm to +9 dBm	up to +12 dBm	
	30 GHz to 40 GHz	-80 dBm to +6 dBm	up to +9 dBm	
	R&S®ZNA43, 2.4 mm interface			
	40 GHz to 43.5 GHz	-60 dBm to +4 dBm	up to +8 dBm	
	R&S®ZNA43, 2.92 mm interface			
	40 GHz to 43.5 GHz			+8 dBm
	R&S®ZNA50			
	10 MHz to 4 GHz	-80 dBm to +16 dBm	up to +20 dBm	
	4 GHz to 20 GHz	-80 dBm to +13 dBm	up to +18 dBm	
	20 GHz to 25 GHz	-80 dBm to +12 dBm	up to +15 dBm	
	25 GHz to 30 GHz	-80 dBm to +9 dBm	up to +12 dBm	
	30 GHz to 40 GHz	-80 dBm to +6 dBm	up to +9 dBm	
	40 GHz to 45 GHz	-60 dBm to +4 dBm	-80 dBm to +7 dBm	
	45 GHz to 50 GHz	-60 dBm to +3 dBm	-80 dBm to +6 dBm	
R&S®ZNA67				
10 MHz to 4 GHz	-80 dBm to +16 dBm	up to +20 dBm		
4 GHz to 20 GHz	-80 dBm to +13 dBm	up to +18 dBm		
20 GHz to 25 GHz	-80 dBm to +11 dBm	up to +14 dBm		
25 GHz to 30 GHz	-80 dBm to +7 dBm	up to +10 dBm		
30 GHz to 40 GHz	-80 dBm to +4 dBm	up to +7 dBm		
40 GHz to 67 GHz	-60 dBm to +5 dBm	-80 dBm to +8 dBm		
Minimum power level using optional source step attenuator (see "Options")		-120 dBm		
Power accuracy, source power -10 dBm	R&S®ZNA26 and R&S®ZNA43			
	10 MHz to 26.5 GHz	< 2.0 dB		
	R&S®ZNA43			
	26.5 GHz to 40 GHz	< 3.0 dB		
	R&S®ZNA43, 2.4 mm interface			
	40 GHz to 43.5 GHz	< 3.0 dB		
	R&S®ZNA43, 2.92 mm interface			
	40 GHz to 43.5 GHz			3.0 dB
	R&S®ZNA50 and R&S®ZNA67			
	10 MHz to 26.5 GHz	< 2.0 dB		
26.5 GHz to 50 GHz	< 3.0 dB			
50 GHz to 67 GHz	< 4.0 dB			



	Specification	Typical	Measured
Power linearity referenced to –10 dBm, no power calibration	source power –40 dBm to +10 dBm <sup>12</sup> , R&S®ZNA26, R&S®ZNA43, R&S®ZNA50, and R&S®ZNA67		
	10 MHz to 20 GHz	< 1.5 dB	0.2 dB
	20 GHz to 40 GHz	< 2 dB	0.2 dB
	R&S®ZNA43, 2.4 mm interface		
	40 GHz to 43.5 GHz	< 2 dB	0.2 dB
	R&S®ZNA43, 2.92 mm interface		
	40 GHz to 43.5 GHz		0.2 dB
	R&S®ZNA50 and R&S®ZNA67		
	40 GHz to 67 GHz	< 2 dB	0.2 dB
	source power < –40 dBm, R&S®ZNA26, R&S®ZNA43, R&S®ZNA50, and R&S®ZNA67		
	10 MHz to 20 GHz	< 2 dB	0.2 dB
	20 GHz to 40 GHz	< 3 dB	0.2 dB
	R&S®ZNA43, 2.4 mm interface		
	40 GHz to 43.5 GHz	< 3 dB	0.2 dB
	R&S®ZNA43, 2.92 mm interface		
40 GHz to 43.5 GHz		0.2 dB	
R&S®ZNA50 and R&S®ZNA67			
40 GHz to 67 GHz	< 3 dB	0.2 dB	
Power resolution	0.01 dB		
Power accuracy, –10 dBm source power, ALC ON	R&S®ZNA26, R&S®ZNA43, R&S®ZNA50 and R&S®ZNA67		
	10 MHz to 100 MHz		2.0 dB
	100 MHz to 26.5 GHz		1.0 dB
	R&S®ZNA43, R&S®ZNA50 and R&S®ZNA67		
	26.5 GHz to 30 GHz		1.0 dB
	30 GHz to 40 GHz		1.5 dB
	40 GHz to 43.5 GHz		2.0 dB
	R&S®ZNA50 and R&S®ZNA67		
	43.5 GHz to 50 GHz		2.0 dB
R&S®ZNA67			
50 GHz to 67 GHz		2.5 dB	
Power linearity, referenced to –10 dBm, ALC ON	source power –40 dBm to +10 dBm <sup>12</sup> , R&S®ZNA26, R&S®ZNA43, R&S®ZNA50 and R&S®ZNA67		
	10 MHz to 100 MHz		1.5 dB
	100 MHz to 67 GHz		0.5 dB
	source power < –40 dBm, R&S®ZNA26, R&S®ZNA43, R&S®ZNA50 and R&S®ZNA67		
	10 MHz to 100 MHz		2.0 dB
	100 MHz to 67 GHz		1.0 dB

	Specification	Typical	Nominal
Second harmonics at –10 dBm	R&S®ZNA26 and R&S®ZNA43		
	10 MHz to 20 MHz	< –23 dBc	–30 dBc
	20 MHz to 16 GHz	< –25 dBc	–40 dBc
	R&S®ZNA50 and R&S®ZNA67		
	10 MHz to 20 MHz	< –23 dBc	–30 dBc
Third harmonics at –10 dBm	R&S®ZNA26 and R&S®ZNA43		
	10 MHz to 20 MHz	< –23 dBc	–30 dBc
	20 MHz to 50 MHz	< –25 dBc	–50 dBc
	50 MHz to 13 GHz	< –40 dBc	–60 dBc
	R&S®ZNA50 and R&S®ZNA67		
	10 MHz to 20 MHz	< –23 dBc	–30 dBc
	20 MHz to 50 MHz	< –25 dBc	–50 dBc
50 MHz to 22 GHz	< –40 dBc	–60 dBc	
Nonharmonic spurious (nom.), low phase noise mode			–70 dBc

<sup>12</sup> Maximum power level is limited to +10 dBm or the maximum specified output power, whichever is smaller.

	Offset	100 Hz	1 kHz	10 kHz	100 kHz	200 kHz	1 MHz	5 MHz
Phase noise (meas.) in dBc (1 Hz), low phase noise mode <sup>13</sup>	R&S®ZNA26, R&S®ZNA43, R&S®ZNA50 and R&S®ZNA67							
	10 MHz to 100 MHz	-108	-137	-141	-139	-141	-141	-142
	100 MHz to .25 GHz	-85	-117	-125	-122	-125	-135	-142
	1.25 GHz to 2.5 GHz	-80	-111	-119	-116	-119	-130	-143
	2.5 GHz to 5 GHz	-74	-105	-113	-111	-113	-124	-139
	5 GHz to 10 GHz	-68	-99	-107	-104	-107	-118	-133
	10 GHz to 20 GHz	-62	-94	-100	-98	-101	-112	-127
	20 GHz to 26.5 GHz	-59	-91	-98	-95	-100	-103	-117
	R&S®ZNA43, R&S®ZNA50 and R&S®ZNA67							
26.5 GHz to 40 GHz	-56	-87	-95	-90	-95	-105	-120	

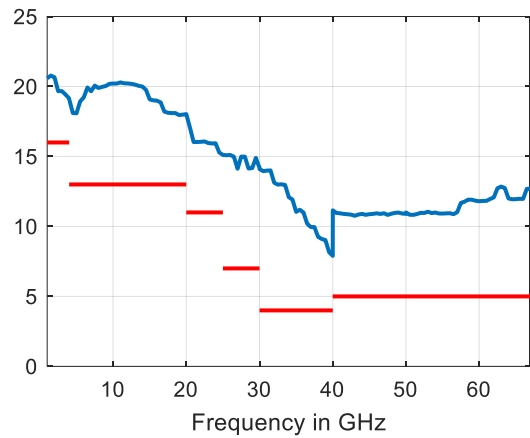
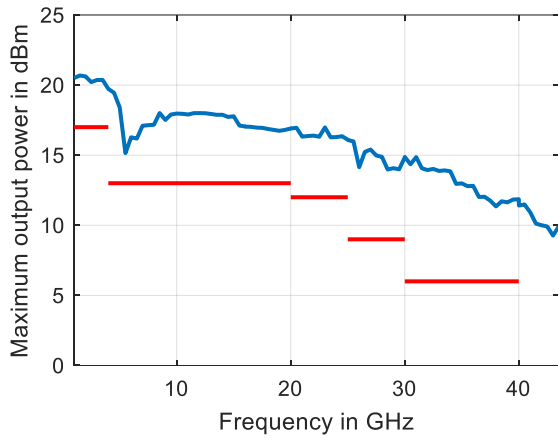

Typical maximum output power in dBm versus frequency for R&S®ZNA43 (left) and R&S®ZNA67 (right) <sup>14</sup>

<sup>13</sup> A further improvement close to carrier can be made by using a low phase noise external reference at 1 GHz using the external frequency reference input.

<sup>14</sup> With R&S®ZNAxx-B16 option.

## Test port input

		Specification	Typical	Measured	Nominal
Match without system error correction, equivalent to raw test port match	R&S®ZNA26, R&S®ZNA43, R&S®ZNA50 and R&S®ZNA67				
	10 MHz to 20 GHz	> 10 dB	18 dB		
	R&S®ZNA26, R&S®ZNA43 and R&S®ZNA67				
	20 GHz to 40 GHz	> 8 dB	15 dB		
	R&S®ZNA50				
	20 GHz to 40 GHz	> 6 dB	13 dB		
	R&S®ZNA43, 2.4 mm interface				
	40 GHz to 43.5 GHz	> 6 dB	10 dB		
Power measurement accuracy at –10 dBm with power calibration using R&S®SMARTerCal (UOSM)	R&S®ZNA43, 2.92 mm interface				
	40 GHz to 43.5 GHz			10 dB	
	R&S®ZNA50 and R&S®ZNA67				
	40 GHz to 67 GHz	> 6 dB	10 dB		
	R&S®ZNA26, R&S®ZNA43, R&S®ZNA50 and R&S®ZNA67				
	10 MHz to 26.5 GHz	< 0.1 dB			
	26.5 GHz to 40 GHz	< 0.2 dB			
	R&S®ZNA43, 2.4 mm interface				
Power measurement accuracy at –10 dBm without power calibration from +18 °C to +28 °C	40 GHz to 43.5 GHz	< 0.2 dB			
	R&S®ZNA43, 2.92 mm interface				
	40 GHz to 43.5 GHz		0.2 dB		
	R&S®ZNA50 and R&S®ZNA67				
	40 GHz to 60 GHz	< 0.2 dB			
	60 GHz to 67 GHz	< 0.3 dB			
	R&S®ZNA26 and R&S®ZNA43				
	10 MHz to 30 GHz	< 1.5 dB			
Compression at test port input, > 0 dBm input level, referenced to –10 dBm	30 GHz to 40 GHz	< 2.0 dB			
	R&S®ZNA43, 2.4 mm interface				
	40 GHz to 43.5 GHz	< 2.5 dB			
	R&S®ZNA43, 2.92 mm interface				
	40 GHz to 43.5 GHz			2.5 dB	
	R&S®ZNA50 and R&S®ZNA67				
	40 GHz to 60 GHz	< 2.5 dB			
	60 GHz to 67 GHz	< 3.0 dB			

		Specification	Typical	Measured
Compression at test port input, > 0 dBm input level, referenced to –10 dBm	R&S®ZNA26, R&S®ZNA43, R&S®ZNA50, and R&S®ZNA67			
	10 MHz to 25 GHz, +8 dBm to +10 dBm	< 0.20 dB	0.10 dB	
	10 MHz to 40 GHz, 0 dBm to +8 dBm	< 0.20 dB	0.05 dB	
	R&S®ZNA43, 2.92 mm interface			
	40 GHz to 43.5 GHz, 0 dBm to +8 dBm			0.05 dB
	R&S®ZNA43, 2.4 mm interface			
	40 GHz to 43.5 GHz, 0 dBm to +8 dBm	< 0.20 dB	0.05 dB	
	R&S®ZNA50 and R&S®ZNA67			
Linearity at test port input, –50 dBm to 0 dBm input level, referenced to –10 dBm	40 GHz to 67 GHz, 0 dBm to +8 dBm	< 0.20 dB	0.05 dB	
	R&S®ZNA26 and R&S®ZNA43, 2.92 mm interface			
	10 MHz to 40 GHz	< 0.05 dB	0.03 dB	
	40 GHz to 43.5 GHz			0.03 dB
	R&S®ZNA43, 2.4 mm interface			
	10 MHz to 43.5 GHz	< 0.05 dB	0.03 dB	
	R&S®ZNA50			
	10 MHz to 50 GHz	< 0.05 dB	0.03 dB	
Damage level	R&S®ZNA67			
	10 MHz to 67 GHz	< 0.05 dB	0.03 dB	
Damage DC voltage		+27 dBm		
		30 V		

Standard configuration	Base unit			Base unit + R&S®ZNAxx-B16 + R&S®ZNAxx-B3n <sup>15</sup>		
	Specifica- tion	Typical	Measured	Specifica- tion	Typical	Measured
Noise level <sup>16</sup> at 1 kHz measurement bandwidth, normalized to 1 Hz	R&S®ZNA26, R&S®ZNA43, R&S®ZNA50 and R&S®ZNA67					
	10 MHz to 30 MHz	< -75 dBm	-100 dBm		< -85 dBm	-110 dBm
	30 MHz to 100 MHz	< -92 dBm	-110 dBm		< -102 dBm	-120 dBm
	100 MHz to 500 MHz	< -107 dBm	-125 dBm		< -117 dBm	-130 dBm
	500 MHz to 30 GHz	< -120 dBm	-132 dBm		< -130 dBm	-142 dBm
	30 GHz to 40 GHz	< -115 dBm	-130 dBm		< -122 dBm	-139 dBm
	R&S®ZNA43, 2.4 mm interface					
	40 GHz to 43.5 GHz	< -105 dBm	-120 dBm		< -111 dBm	-126 dBm
	R&S®ZNA43, 2.92 mm interface					
	40 GHz to 43.5 GHz			-120 dBm		-126 dBm
R&S®ZNA50 and R&S®ZNA67						
40 GHz to 50 GHz	< -105 dBm	-120 dBm		< -111 dBm	-126 dBm	
50 GHz to 67 GHz	< -104 dBm	-119 dBm		< -110 dBm	-125 dBm	

Reversed coupler configuration <sup>17</sup>	Base unit + R&S®ZNAxx-B16			Base unit + R&S®ZNAxx-B16 + R&S®ZNAxx-B3n <sup>15</sup>		
	Specifica- tion	Typical	Measured	Specifica- tion	Typical	Measured
Noise level <sup>16</sup> at 1 kHz measurement bandwidth, normalized to 1 Hz	R&S®ZNA26, R&S®ZNA43, R&S®ZNA50 and R&S®ZNA67					
	10 MHz to 30 MHz	< -105 dBm	-122 dBm		< -115 dBm	-132 dBm
	30 MHz to 100 MHz	< -117 dBm	-139 dBm		< -127 dBm	-149 dBm
	100 MHz to 500 MHz	< -127 dBm	-141 dBm		< -137 dBm	-151 dBm
	500 MHz to 30 GHz	< -127 dBm	-141 dBm		< -137 dBm	-151 dBm
	30 GHz to 40 GHz	< -122 dBm	-137 dBm		< -129 dBm	-145 dBm
	R&S®ZNA43, 2.4 mm interface					
	40 GHz to 43.5 GHz	< -112 dBm	-132 dBm		< -118 dBm	-138 dBm
	R&S®ZNA43, 2.92 mm interface					
	40 GHz to 43.5 GHz			-132 dBm		-138 dBm
R&S®ZNA50 and R&S®ZNA67						
40 GHz to 50 GHz	< -110 dBm	-120 dBm		< -118 dBm	-130 dBm	
50 GHz to 67 GHz	< -108 dBm	-120 dBm		< -116 dBm	-130 dBm	

Direct source and receiver access <sup>18</sup>	Base unit + R&S®ZNAxx-B16		
	Specifica- tion	Typical	Measured
Noise level <sup>16</sup> at 1 kHz measurement bandwidth, normalized to 1 Hz	R&S®ZNA26, R&S®ZNA43, R&S®ZNA50 and R&S®ZNA67		
	10 MHz to 30 MHz	< -115 dBm	-132 dBm
	30 MHz to 100 MHz	< -127 dBm	-149 dBm
	100 MHz to 500 MHz	< -137 dBm	-151 dBm
	500 MHz to 30 GHz	< -137 dBm	-151 dBm
	30 GHz to 40 GHz	< -129 dBm	-145 dBm
	R&S®ZNA43, 2.4 mm interface		
	40 GHz to 43.5 GHz	< -118 dBm	-138 dBm
	R&S®ZNA43, 2.92 mm interface		
	40 GHz to 43.5 GHz		-138 dBm
R&S®ZNA50 and R&S®ZNA67			
40 GHz to 50 GHz	< -118 dBm	-128 dBm	
50 GHz to 67 GHz	< -116 dBm	-126 dBm	

<sup>15</sup> Receiver step attenuator in 0 dB position.

<sup>16</sup> The noise level is defined as the RMS value of the specified noise floor. For different bandwidth add  $[10 \times \log_{10}(\text{bandwidth} / 1\text{Hz})]$  to the given noise level.

<sup>17</sup> With the R&S®ZNAxx-B16 option installed, the jumpers of the direct source and receiver access connectors "Source" and "Meas" are swapped to horizontal position to enable the reverse coupler operation.

<sup>18</sup> Using the direct source and receiver access connectors "Meas In" and "Ref In" (jumpers removed) and no receiver attenuator installed or in 0 dB position.

## Display

Main screen		touchscreen, 30.7 cm (12.1") diagonal, WXGA, 18-bit color LCD
Main screen resolution		1280 × 800 pixel, 125 dpi
Pixel failure rate		$\leq 1 \times 10^{-5}$
Auxiliary screen		touchscreen, 17.8 cm (7") diagonal, WVGA, 18-bit color LCD
Auxiliary screen resolution		480 × 800 pixel, 125 dpi
Pixel failure rate		$\leq 1.5 \times 10^{-5}$

## Internal PC

<b>Removable PC</b> <sup>19</sup>		IPC 11/4
CPU		Intel Core i7, x64
Clock rate		2.3 GHz
RAM		16 Gbyte DDR3
Operating system		Windows 10 IoT Enterprise LTSC 2016
Solid state drive		$\geq 128$ Gbyte

## Front panel connectors

USB	2.0 device connector (type A)	3
-----	-------------------------------	---

## Rear panel connectors

GPIB interface	remote control interface in line with IEEE 488, IEC 60625; 24-pin	
External handler I/O	connector for R&S®ZNB-T-Z14 handler I/O option (external) for R&S®ZNA	
LAN	local area network connector, 8-pin, RJ-45, 1 Gbit/s	
USB	2.0 device connector (type A)	4
USB device	2.0 secondary connector (type B)	1
External monitor	DVI-D digital-only connector	1
	DisplayPort	1

<b>REF IN</b>	input for external reference frequency signal	
Connector type		
BNC, female	input frequency range	1 MHz to 50 MHz
	step size	1 Hz
	input impedance	100 $\Omega$
SMA, female	input frequency range	100 MHz or 1 GHz
	step size	fixed frequency
	input impedance	50 $\Omega$
Maximum permissible deviation	1 kHz	
Input power	-10 dBm to +15 dBm	

<b>REF OUT</b>	output for external reference frequency signal	
Connector type		
BNC, female	output impedance	50 $\Omega$
	output frequency	10 MHz
	output frequency accuracy	1 Hz
	output power	+9 dBm $\pm$ 4 dB

<sup>19</sup> Internal PC is subject to change without notice.

<b>USER CONTROL</b>	diverse control and trigger signals, 25-pin D-Sub, 3.3 V TTL, for controlling external generators, for limit checks, sweep signals, etc.	
CHANNEL BIT 0 to CHANNEL BIT 3	pin 8 to pin 11 (outputs)	channel-specific, user-configurable bits
CHANNEL BIT 4 to CHANNEL BIT 7	pin 16 to pin 19 (outputs)	channel-specific, user-configurable bits
DRIVE PORT 1 to DRIVE PORT 4	pin 16 to pin 19 (outputs)	indicates drive ports (can alternatively be used for channel bits 4 to 7)
PASS 1 and PASS 2	pin 13 and pin 14 (outputs)	pass/fail results of limit checks
BUSY	pin 4 (output)	measurements running
READY FOR TRIGGER	pin 6 (output)	ready for trigger
EXT GEN TRIGGER	pin 21 (output)	control signal for external generator
EXT GEN BLANK	pin 22 (input)	handshake signal from external generator
EXTERNAL TRIGGER	pin 2 (input)	first trigger input for analyzer, 5 V tolerant
EXTERNAL TRIGGER 2	pin 25 (input)	second trigger input for analyzer, 5 V tolerant

<b>Trigger In A</b>	trigger input for analyzer	
Connector type		BNC, female
TTL signal (edge-triggered or level-triggered)		3 V, 5 V tolerant
Polarity	selectable	positive or negative
Minimum pulse width		1 $\mu$ s
Input impedance		5 k $\Omega$ (nom.)

## Options

### R&S®ZNA-B7 memory extension for data streaming

Timing resolution	$\geq 20$ MHz resolution bandwidth	8 ns
	$\geq 10$ MHz resolution bandwidth	16 ns
Number of wave quantities capturable	$\geq 20$ MHz resolution bandwidth	4
	$\geq 10$ MHz resolution bandwidth	8

### R&S®ZNA-B8 mmWave converter LO

The data is valid in the temperature range from +18 °C to +28 °C.

Connector type		2.92 mm, female
Power range	30 MHz to 26.5 GHz	
	specified	-10 dBm to +20 dBm
	typical	+25 dBm
Power accuracy, -10 dBm source power	30 MHz to 26.5 GHz	
	specified	< 2.0 dB
Power linearity referenced to 0 dBm, no power calibration	30 MHz to 26.5 GHz, -10 dBm to +20 dBm	
	specified	< 2 dB
	typical	0.2 dB
Power resolution	specified	0.01 dB
Second harmonics at 0 dBm	1 GHz to 20 GHz	
	specified	< -15 dBc
	typical	-20 dBc
Third harmonics at 0 dBm	1 GHz to 13 GHz	
	specified	< -25 dBc
	typical	-30 dBc

## R&S®ZNA-B15 RFFE GPIO interface

The R&S®ZNA-B15 RFFE GPIO interfaces (models .02 and .03) provide two independent MIPI RFFE busses, and ten individually configurable output lanes with different power handling capabilities.

Connector type		25-pin D-Sub, female
Ground	analog and digital	pin 1, 3, 5, 11 and 22

Output voltage	Output pin	Voltage range	Voltage step size	Maximum current
RFFE port 1, VIO	pin 2	0 to +2 V	1 mV	20 mA
RFFE port 1, DATA	pin 15	0 to +2 V	1 mV	20 mA
RFFE port 1, CLK	pin 14	configurable clock rate: 31.25 kHz to 26 MHz		
		0 to +2 V	1 mV	20 mA
RFFE port 2, VIO	pin 4	0 to +2 V	1 mV	20 mA
RFFE port 2, DATA	pin 17	0 to +2 V	1 mV	20 mA
RFFE port 2, CLK	pin 16	configurable clock rate: 31.25 kHz to 26 MHz		
		0 to +2 V	1 mV	20 mA
GPIO 1 to GPIO 8	pin 6 to pin 9, pin 18 to pin 21	-5 V to +10 V, typ. -6 V to +12 V	5 mV	20 mA
GPIO 9 and 10	pin 10 and 23	-5 V to +10 V, typ. -6 V to +12 V	5 mV	100 mA

The R&S®ZNA-B15 RFFE GPIO interface (model .03) provides voltage and current measurement with switchable source resistance. 32 internal ADC channels measure voltage and current at each RFFE and GPIO pin simultaneously.

Voltage measurement	Input pin	Voltage range	Resolution	Accuracy <sup>20</sup>
RFFE port 1 and 2, VIO, DATA, CLK	pin 2 and 4, pin 14 to pin 17	0 to +3 V	100 µV	2 % ± 20 mV
GPIO 1 to GPIO 10	pin 6 to pin 9, pin 18 to pin 21, pin 10, pin 23	-5 V to +10 V	100 µV	2 % ± 50 mV

Current measurement	Input pin	Source shunt resistor	Current range	Resolution	Accuracy <sup>20</sup>	Repeatability
		current values are valid for GPIO voltages from -5 V to +8 V				
RFFE port 1 and 2, VIO, DATA, CLK, GPIO 1 to GPIO 8	pin 6 to pin 9, pin 18 to pin 21	10 Ω	-20 mA to +20 mA	10 µA	2 % ± 200 µA	< 100 µA
		100 Ω	-2 mA to +2 mA	1 µA	2 % ± 20 µA	< 10 µA
		1 kΩ	-200 µA to +200 µA	100 nA	3 % ± 3 µA	< 1 µA
		10 kΩ	-20 µA to +20 µA	10 nA	5 % ± 500 nA	< 100 nA
		100 kΩ	-2 µA to +2 µA	1 nA	5 % ± 50 nA	< 10 nA
GPIO 9 and 10	pin 10 and 23		-100 mA to +100 mA	10 µA	3 % ± 3 mA	< 100 µA

<sup>20</sup> x % ± y is to be understood as x % of reading ± y.

**R&S®ZNA-B26 direct IF access**

Connector type		SMA, female
Impedance		50 Ω (nom.)
Frequency range	input (ADC clock 125 MHz)	100 kHz to 1 GHz (nom.)
	output, RF ≤ 5 GHz	100 kHz to 60 MHz (nom.)
	output, RF > 5 GHz	100 kHz to 2 GHz (nom.)
Damage level		+20 dBm, 10 V DC
<b>Interfaces</b>		
IF Reference 1		input/output
IF Meas 1		input/output
IF Reference 2		input/output
IF Meas 2		input/output
IF Reference 3 (4-port model)		input/output
IF Meas 3 (4-port model)		input/output
IF Reference 4 (4-port model)		input/output
IF Meas 4 (4-port model)		input/output
Input 0.1 dB compression	30 MHz, IF gain: 0 dB	-4 dBm (meas.)

**R&S®ZNA-B91 trigger and control I/O board**

Connector type		BNC, female
<b>Interfaces</b>		
Trigger In B	input	3 V, 5 V tolerant, impedance: 10 kΩ (nom.)
Trigger In C		
Trigger In D		
Trigger Out A	output	logic high: typ. 5 V, impedance: 50 Ω (nom.)
Trigger Out B		
Trigger Out C		
Trigger Out D		
PuMo In/Out A	input/output	input: 3 V, 5 V tolerant, impedance: 10 kΩ (nom.)
PuMo In/Out B		
PuMo In/Out C		output: logic high: typ. 5 V, impedance: 50 Ω (nom.)
PuMo In/Out D		
Ready for Trigger	output	logic high: typ. 5 V, impedance: 50 Ω (nom.)
Busy	output	logic high: typ. 5 V, impedance: 50 Ω (nom.)
RF Off Control	input	pull up resistor: 4.7 kΩ on 3.3V



## R&S®ZNA26-B16, R&S®ZNA43-B16, R&S®ZNA50-B16 and R&S®ZNA67-B16 direct source and receiver access

Connector type	R&S®ZNA26-B16, R&S®ZNA43-B16	2.92 mm, female
	R&S®ZNA50-B16, R&S®ZNA67-B16	1.85 mm, female
Frequency range	R&S®ZNA26-B16	
	specified	10 MHz to 26.5 GHz
	nominal	100 kHz to 26.5 GHz
	R&S®ZNA43-B16, test port 2.4 mm interface	
	specified	10 MHz to 40 GHz
	measured	40 GHz to 43.5 GHz
	nominal	100 kHz to 43.5 GHz
	R&S®ZNA43-B16, test port 2.92 mm interface	
	specified	10 MHz to 40 GHz
	measured	40 GHz to 43.5 GHz
	nominal	100 kHz to 43.5 GHz
	R&S®ZNA50-B16	
	specified	10 MHz to 50 GHz
	nominal	100 kHz to 50 GHz
R&S®ZNA67-B16		
specified	10 MHz to 67 GHz	
nominal	100 kHz to 67 GHz	
Damage level	Source In	+30 dBm, 30 V DC
	other inputs	+20 dBm, 0 V DC
Dynamic range is reduced by	10 MHz to 1 GHz	0 dB
	1 GHz to 40 GHz	2 dB
	40 GHz to 50 GHz	3 dB
	50 GHz to 60 GHz	4 dB
	60 GHz to 67 GHz	5 dB
Input 0.1 dB compression, receiver step attenuator: 0 dB	≤ 10 GHz	-8 dBm (meas.)
	> 10 GHz	-6 dBm (meas.)

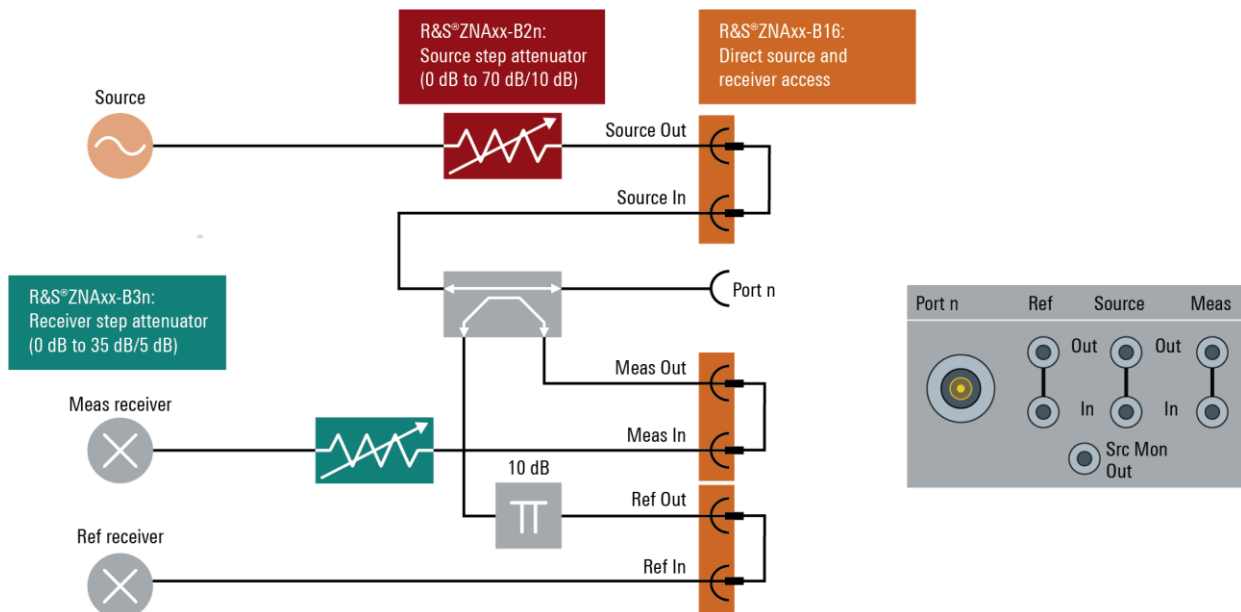

Test set configuration for R&S®ZNAxx-B16 direct source and receiver access

## R&S®ZNA26-B21/-B22/-B23/-B24, R&S®ZNA43-B21/-B22/-B23/-B24, R&S®ZNA50-B21/-B22/-B23/-B24 and R&S®ZNA67-B21/-B22/-B23/-B24 source step attenuators

Frequency range	R&S®ZNA26-B21/-B22/-B23/-B24	10 MHz to 26.5 GHz
	R&S®ZNA43-B21/-B22/-B23/-B24	10 MHz to 43.5 GHz
	R&S®ZNA50-B21/-B22/-B23/-B24	10 MHz to 50 GHz
	R&S®ZNA67-B21/-B22/-B23/-B24	10 MHz to 67 GHz
Attenuation (nominal)	R&S®ZNA26 and R&S®ZNA43	0 dB to 70 dB, in 10 dB steps
	R&S®ZNA50 and R&S®ZNA67	0 dB to 50 dB, in 10 dB steps
Minimum output power is reduced to		-120 dBm
Maximum output power and dynamic range are reduced by	R&S®ZNA26-B21/-B22/-B23/-B24, R&S®ZNA43-B21/-B22/-B23/-B24	
	10 MHz to 16 GHz	1 dB
	16 GHz to 30 GHz	2 dB
	30 GHz to 40 GHz	3 dB
	40 GHz to 43.5 GHz	4 dB
	R&S®ZNA50-B21/-B22/-B23/-B24, R&S®ZNA67-B21/-B22/-B23/-B24	
	10 MHz to 4 GHz	1 dB
	4 GHz to 16 GHz	2 dB
	16 GHz to 30 GHz	3 dB
	30 GHz to 40 GHz	6 dB
40 GHz to 67 GHz	7 dB	

## R&S®ZNA26-B31/-B32/-B33/-B34, R&S®ZNA43-B31/-B32/-B33/-B34, R&S®ZNA50-B31/-B32/-B33/-B34 and R&S®ZNA67-B31/-B32/-B33/-B34 receiver step attenuators

Frequency range	R&S®ZNA26-B31/-B32/-B33/-B34	10 MHz to 26.5 GHz
	R&S®ZNA43-B31/-B32/-B33/-B34	10 MHz to 43.5 GHz
	R&S®ZNA50-B31/-B32/-B33/-B34	10 MHz to 50 GHz
	R&S®ZNA67-B31/-B32/-B33/-B34	10 MHz to 67 GHz
Attenuation	10 dB preset setting	0 dB to 35 dB, in 5 dB steps
Step attenuator accuracy; attenuation > 0 dB, referenced to attenuation = 10 dB	10 MHz to 20 GHz	≤ 1 dB
	20 GHz to 40 GHz	≤ 1.5 dB
	40 GHz to 50 GHz	≤ 2 dB
	50 GHz to 60 GHz	≤ 2.5 dB
	60 GHz to 67 GHz	≤ 3 dB
Dynamic range is increased by	10 MHz to 500 MHz	0 dB
	500 MHz to 1 GHz	5 dB
	1 GHz to 30 GHz	8 dB
	30 GHz to 40 GHz	7 dB
	40 GHz to 67 GHz	6 dB
Noise floor is reduced by	10 MHz to 30 GHz	10 dB
	30 GHz to 40 GHz	7 dB
	40 GHz to 67 GHz	6 dB

## R&S®ZNA26-B41/-B42/-B43/-B44, R&S®ZNA43-B41/-B42/-B43/-B44, R&S®ZNA50-B41/-B42/-B43/-B44 and R&S®ZNA67-B41/-B42/-B43/-B44 internal pulse modulators

Frequency range	R&S®ZNA26-B41/-B42/-B43/-B44	10 MHz to 26.5 GHz
	R&S®ZNA43-B41/-B42/-B43/-B44	10 MHz to 43.5 GHz
	R&S®ZNA50-B41/-B42/-B43/-B44	10 MHz to 50 GHz
	R&S®ZNA67-B41/-B42/-B43/-B44	10 MHz to 67 GHz
Pulse generator	pulse period	200 ns to 30 s, in 8 ns steps (nom.)
	pulse width	8 ns to 15 s, in 4 ns steps (nom.)
Pulse modulator	minimum pulse width	40 ns (nom.)
On/off ratio	10 MHz to 18 GHz	80 dB (nom.)
	18 GHz to 67 GHz	100 dB (nom.)
Rise/fall time		20 ns (nom.)
Dynamic range		no impact

## R&S®ZNA26-B161/R&S®ZNA43-B161 source monitor access port 1 and R&S®ZNA26-B163/R&S®ZNA43-B163 source monitor access port 1 and port 3

Connector type		2.92 mm, female
Frequency range	R&S®ZNA26-B161/-B163	10 MHz to 26.5 GHz
	R&S®ZNA43-B161/-B163	10 MHz to 43.5 GHz
Nominal reference path attenuation		20 dB (nom.)
Maximum output power and dynamic range are reduced by	10 MHz to 30 GHz	2 dB
	30 GHz to 40 GHz	3 dB
	40 GHz to 43.5 GHz	4 dB

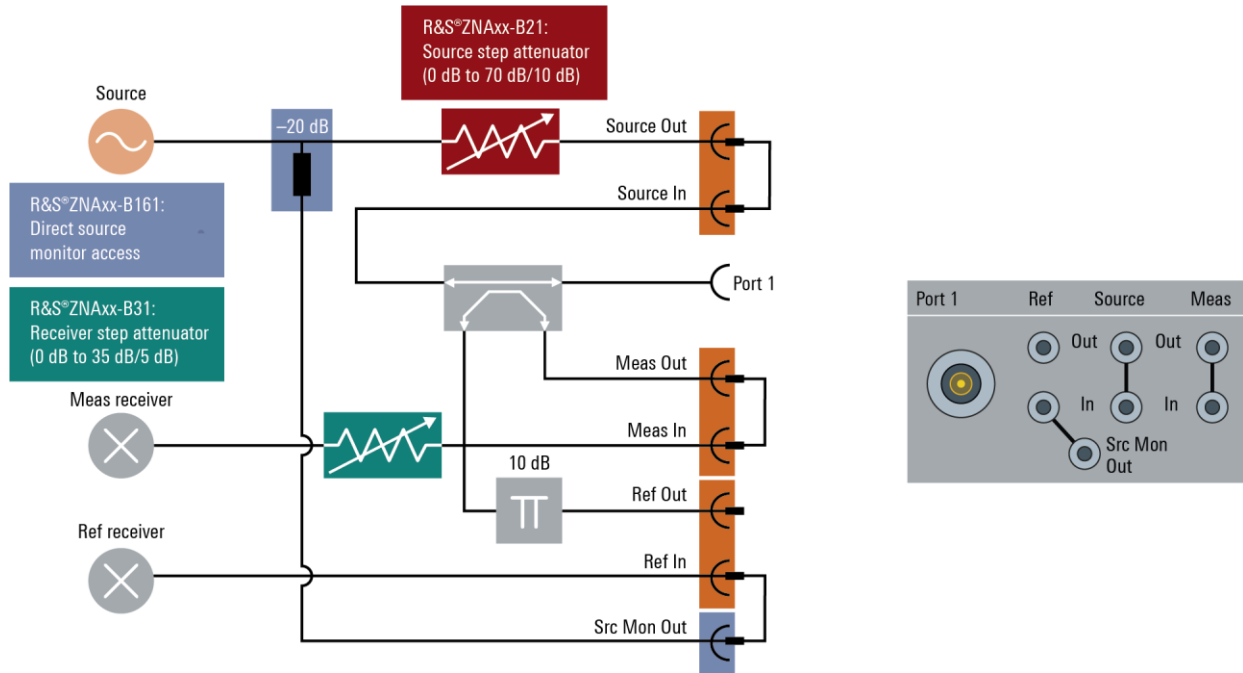

Test set configuration for R&S®ZNAxx-B161 source monitor access port 1

## R&S®ZNA26-B212, R&S®ZNA43-B212 internal combiner, port 1 and port 2

Frequency range	R&S®ZNA26-B212	10 MHz to 26.5 GHz
	R&S®ZNA43-B212	10 MHz to 43.5 GHz
Maximum output power and dynamic range are reduced by	10 MHz to 30 GHz	1 dB
	30 GHz to 40 GHz	2 dB
	40 GHz to 43.5 GHz	3 dB
Maximum output power and dynamic range in combined state for ports 1 and 2 are reduced by	10 MHz to 30 MHz	10 dB
	30 MHz to 100 MHz	7 dB
	100 MHz to 1 GHz	6 dB
	1 GHz to 16 GHz	7 dB
	16 GHz to 30 GHz	8 dB
	30 GHz to 43.5 GHz	9 dB
Power range		no impact
Power accuracy		no impact

Measurements in reverse direction (load match) are possible with enabled internal combiner for two tone signals.

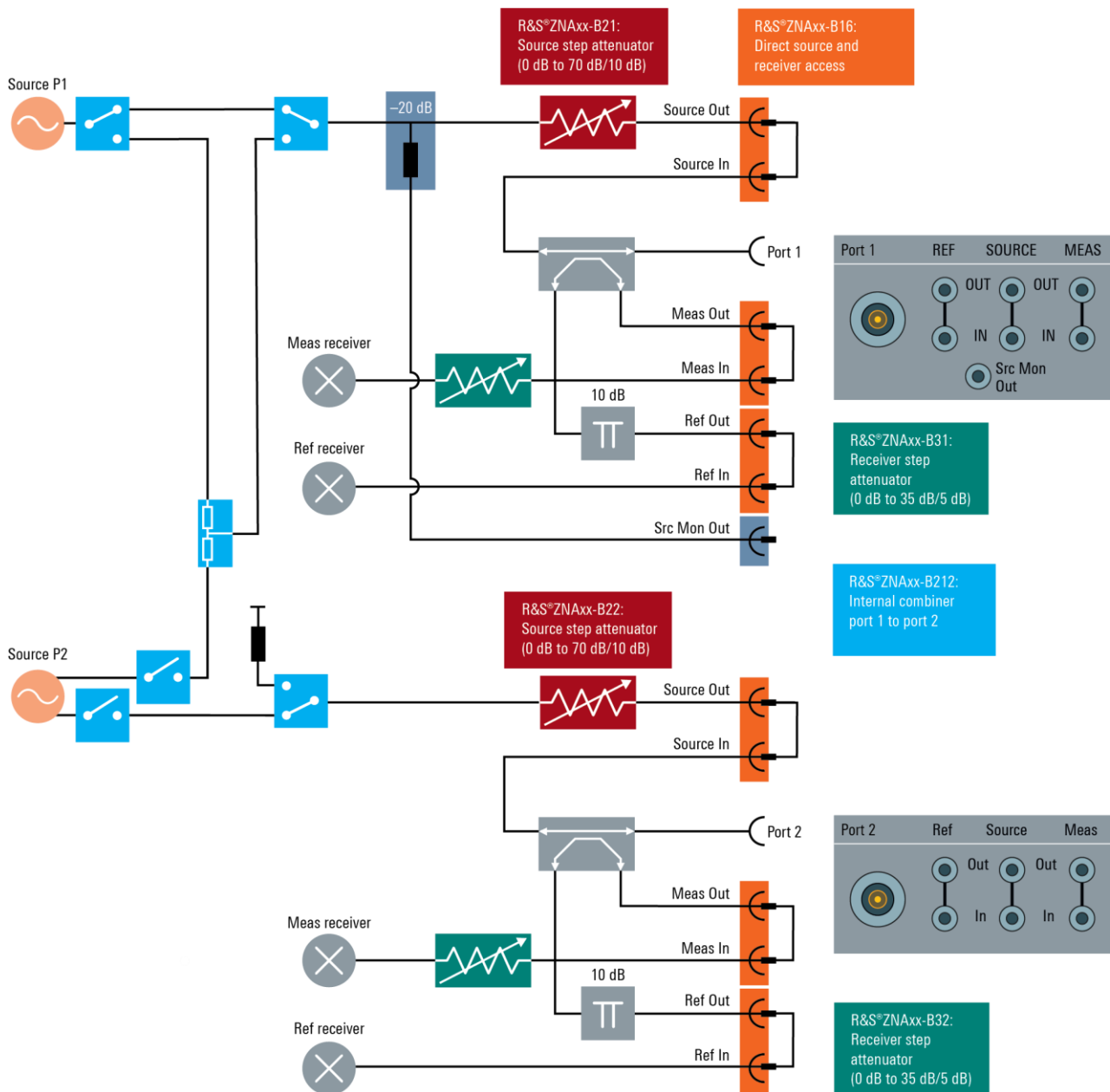

Test set configuration for R&S®ZNAxx-B212 internal combiner, port 1 and port 2

## R&S®ZNA26-B213, R&S®ZNA43-B213 internal combiner, port 1 and port 3

Frequency range	R&S®ZNA26-B213	10 MHz to 26.5 GHz
	R&S®ZNA43-B213	10 MHz to 43.5 GHz
Maximum output power and dynamic range are reduced by	10 MHz to 30 GHz	1 dB
	30 GHz to 40 GHz	2 dB
	40 GHz to 43.5 GHz	3 dB
Maximum output power and dynamic range in combined state for ports 1 and 3 are reduced by	10 MHz to 30 MHz	10 dB
	30 MHz to 100 MHz	7 dB
	100 MHz to 1 GHz	6 dB
	1 GHz to 16 GHz	7 dB
	16 GHz to 30 GHz	8 dB
	30 GHz to 43.5 GHz	9 dB
Power range		no impact
Power accuracy		no impact

Measurements in reverse direction (load match) are possible with enabled internal combiner for two tone signals.

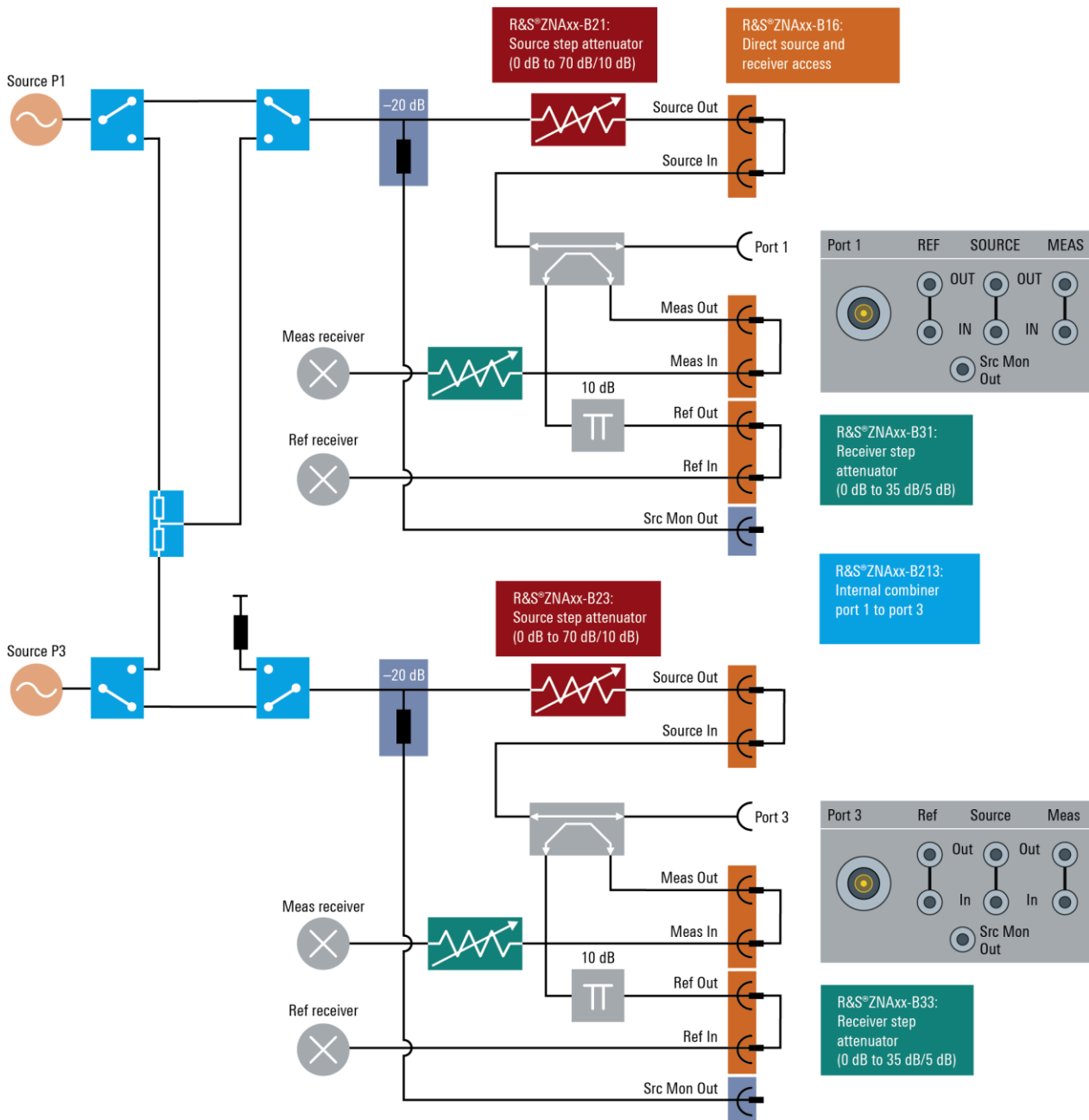

Test set configuration for R&S®ZNAxx-B213 internal combiner, port 1 and port 3

## R&S®ZNA26-B302, R&S®ZNA43-B302 low-noise amplifier, port 2

Frequency range	R&S®ZNA26-B302 R&S®ZNA43-B302	10 MHz to 26.5 GHz 10 MHz to 43.5 GHz
Input noise and dynamic range are reduced by	10 MHz to 40 GHz	3 dB
Power measurement accuracy at -20 dBm without power calibration from +18 °C to +28 °C	10 MHz to 30 GHz 30 GHz to 40 GHz	< 2 dB < 2.5 dB
Noise level at 1 kHz measurement bandwidth, normalized to 1 Hz, low-noise amplifier: 25 dB gain, normal port configuration	R&S®ZNA26-B302	
	10 MHz to 30 MHz	< -90 dBm
	30 MHz to 100 MHz	< -112 dBm
	100 MHz to 500 MHz	< -124 dBm
	500 MHz to 26.5 GHz	< -140 dBm
	R&S®ZNA43-B302	
	10 MHz to 30 MHz	< -90 dBm
	30 MHz to 100 MHz	< -107 dBm
	100 MHz to 500 MHz	< -122 dBm
	500 MHz to 30 GHz	< -135 dBm
Noise level at 1 kHz measurement bandwidth, normalized to 1 Hz, low-noise amplifier: 30 dB gain, reversed coupler configuration	R&S®ZNA26-B302	
	10 MHz to 30 MHz	-148 dBm (meas.)
	30 MHz to 100 MHz	-158 dBm (meas.)
	100 MHz to 500 MHz	-162 dBm (meas.)
	500 MHz to 26.5 GHz	-156 dBm (meas.)
	R&S®ZNA43-B302	
	10 MHz to 30 MHz	-144 dBm (meas.)
	30 MHz to 100 MHz	-153 dBm (meas.)
	100 MHz to 500 MHz	-157 dBm (meas.)
	500 MHz to 30 GHz	-158 dBm (meas.)
30 GHz to 40 GHz	-157 dBm (meas.)	
Damage level at test port		0 dBm
Test port input 0.1 dB compression, low-noise amplifier: 30 dB gain, reversed coupler configuration	referenced to -60 dBm	-40 dBm (meas.)
Receiver noise figure, low-noise amplifier: 30 dB gain, reversed coupler configuration	100 MHz to 40 GHz	17 dB (meas.)

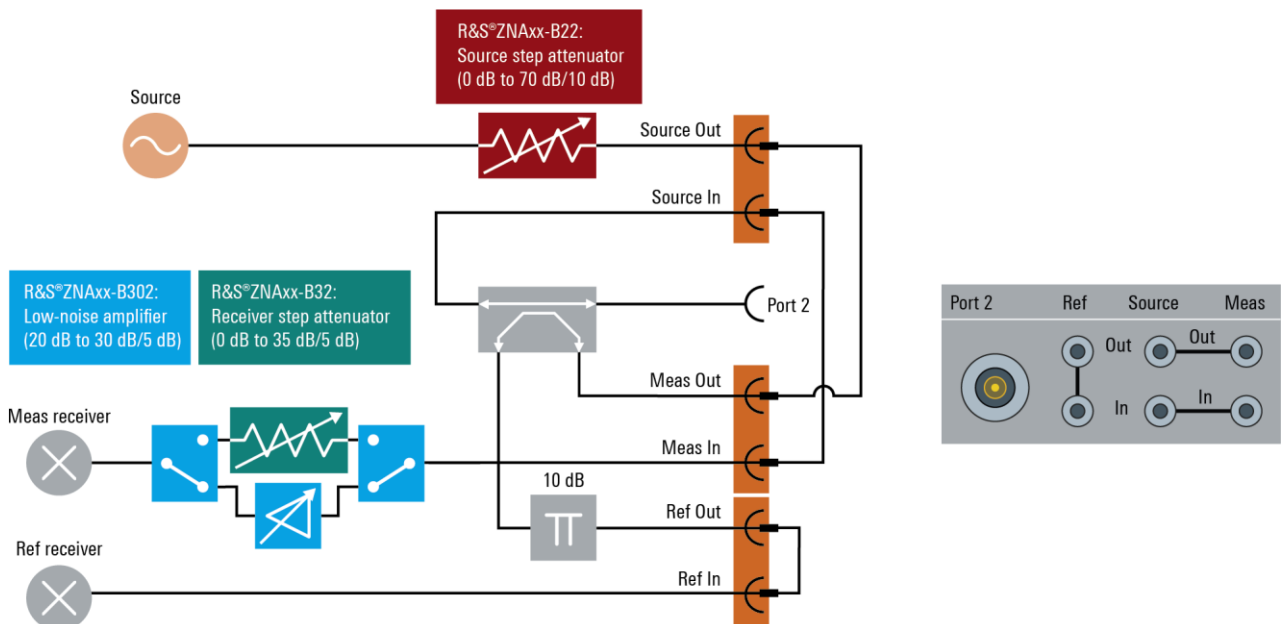

Test set configuration for R&S®ZNAxx-B302 low-noise amplifier port 2, with reversed coupler configuration

## R&S®ZNA26-B501, R&S®ZNA43-B501 low power spurious reduction, port 1

Frequency range	R&S®ZNA26-B501	10 MHz to 26.5 GHz
	R&S®ZNA43-B501	10 MHz to 43.5 GHz
Input noise and dynamic range are reduced by	10 MHz to 40 GHz	3 dB
Power measurement accuracy at $-10$ dBm without power calibration from $+18$ °C to $+28$ °C	10 MHz to 30 GHz	$< 2$ dB
	30 GHz to 40 GHz	$< 2.5$ dB
	40 GHz to 43.5 GHz	$< 3$ dB
Noise level at 1 kHz measurement bandwidth, normalized to 1 Hz, 0 dB receiver step attenuation, normal port configuration	R&S®ZNA26-B501	
	10 MHz to 30 MHz	$< -90$ dBm
	30 MHz to 100 MHz	$< -112$ dBm
	100 MHz to 500 MHz	$< -127$ dBm
	500 MHz to 26.5 GHz	$< -140$ dBm
	R&S®ZNA43-B501	
	10 MHz to 30 MHz	$< -90$ dBm
	30 MHz to 100 MHz	$< -107$ dBm
	100 MHz to 500 MHz	$< -121$ dBm
	500 MHz to 30 GHz	$< -135$ dBm
30 GHz to 40 GHz	$< -130$ dBm	
40 GHz to 43.5 GHz	$< -125$ dBm	
Measured low power spurious level, with R&S®ZNAxx-B161/-B163, source step attenuation: 40 dB or higher, at test port	10 MHz to 22 GHz	$-110$ dBm (meas.)
	22 GHz to 43.5 GHz	$-100$ dBm (meas.)

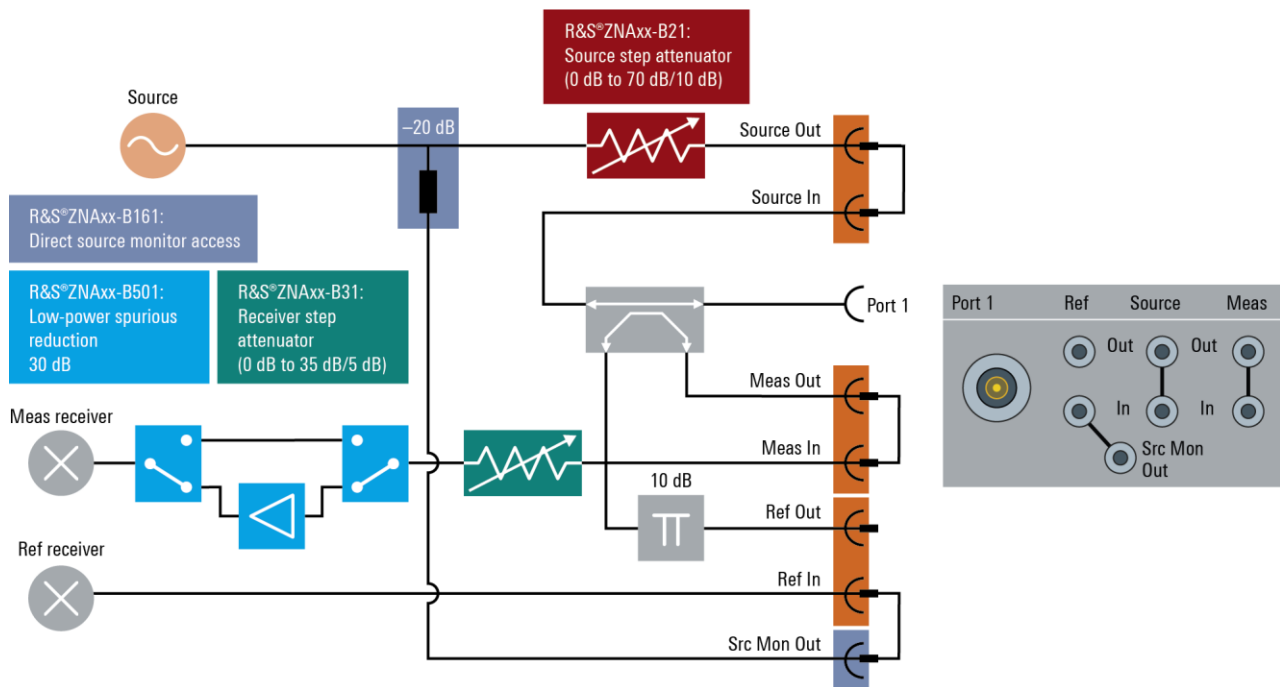

Test set configuration for R&S®ZNAxx-B501 low power spurious reduction port 1

## R&S®ZNA-K1 spectrum analyzer mode (based on fast Fourier transform)

Impedance		50 Ω
Test port connector	R&S®ZNA26	3.5 mm, male, ruggedized
	R&S®ZNA43, 2.92 mm interface	2.92 mm, male, ruggedized
	R&S®ZNA43, 2.4 mm interface	2.4 mm, male, ruggedized
	R&S®ZNA50	2.4 mm, male, ruggedized
	R&S®ZNA67	1.85 mm, male, ruggedized
Frequency range	R&S®ZNA26	10 MHz to 26.5 GHz
	R&S®ZNA43	10 MHz to 43.5 GHz
	R&S®ZNA50	10 MHz to 50 GHz
	R&S®ZNA67	10 MHz to 67 GHz
Test port		selectable
DC block		standard
Number of points		2 to 100001
Resolution bandwidth (–3 dB)	1/1.5/2/3/5/7 steps	1 Hz to 1.5 MHz

Standard configuration	Base unit	
	Nominal	Base unit + R&S®ZNAxx-B16 + R&S®ZNAxx-B3n Nominal
Noise level <sup>21</sup> at 1 kHz measurement bandwidth using RMS detector, normalized to 1 Hz, 10 dB IF gain	R&S®ZNA26, R&S®ZNA43, R&S®ZNA50 and R&S®ZNA67	
	10 MHz to 30 MHz	–100 dBm
	30 MHz to 100 MHz	–110 dBm
	100 MHz to 500 MHz	–125 dBm
	500 MHz to 30 GHz	–132 dBm
	30 GHz to 40 GHz	–130 dBm
	40 GHz to 50 GHz	–118 dBm
50 GHz to 67 GHz	–115 dBm	
		–121 dBm

## R&S®ZNA-K5 vector corrected converter measurements

Recommended setup and options	4-port R&S®ZNA, + R&S®ZNA-K4 + R&S®ZNA-B5 + R&S®ZNA-B8 mmWave converter LO + R&S®ZN-ZM292 calibration mixer + calibration accessories
-------------------------------	--

## R&S®ZNA-K6 phase-coherent source control

Frequency range	R&S®ZNA26	10 MHz to 26.5 GHz
	R&S®ZNA43	10 MHz to 43.5 GHz
	R&S®ZNA50	10 MHz to 50 GHz
	R&S®ZNA67	10 MHz to 67 GHz
Phase accuracy	10 MHz to 10 GHz	0.1° (nom.)
	10 GHz to 30 GHz	0.2° (nom.)
	30 GHz to 43.5 GHz	0.3° (nom.)

## R&S®ZNA-K8 mmWave converter support

Recommended setup and options	two mmWave converters with 2-port R&S®ZNA or four mmWave converters with 4-port R&S®ZNA, + R&S®ZNA-K8 + R&S®ZNA-B8 + R&S®ZNA-B26 + R&S®ZCAKN (contains splitter and adapters) + accessories (test cables etc.)
Alternative setup and options	two mmWave converters with 4-port R&S®ZNA, + R&S®ZNA-K8 + R&S®ZNAxx-B16 + R&S®ZCAKN (contains splitter and adapters) + accessories (test cables etc.)

<sup>21</sup> The noise level is defined as the RMS value of the specified noise floor.



## R&S®ZNA-K9 group delay measurements

Recommended setup and options	4-port R&S®ZNA, + R&S®ZNAxx-B213 + R&S®ZNA-B5 + R&S®ZNA-K4 + R&S®ZNA-K9 2-port R&S®ZNA, + R&S®ZNAxx-B212 + R&S®ZNAxx-B52 + R&S®ZNA-K4 + R&S®ZNA-K9
Alternative setup and options	4-port R&S®ZNA, + R&S®ZNA-K4 + R&S®ZNA-K9 + R&S®ZNAxx-Z9

## R&S®ZNA-K30 noise figure measurement

Recommended setup and options	use port 1 as driving and port 2 as receiving port, + R&S®ZNAxx-B16 + R&S®ZNAxx-B21 + R&S®ZNAxx-B32 + R&S®ZNAxx-B161 + R&S®ZNAxx-B302 + diode power sensor (e.g + R&S®NRP40S) + accessories (test cables, fixed attenuators: 3 dB/6 dB/10 dB etc.), see additional application note 1SL378
-------------------------------	--

## R&S®ZNA-K980 health and utilization monitoring service (HUMS)<sup>22, 23</sup>

Interfaces	protocols and interfaces supported for data readout and display	<ul style="list-style-type: none"> <li>• SNMP (v1, v2c, v3)</li> <li>• REST (JSON)</li> <li>• SCPI</li> <li>• device web</li> </ul>
Services	information provided	<ul style="list-style-type: none"> <li>• device information (model, serial number, BIOS, date, time, system, HUMS and software information)</li> <li>• user-defined information tags (e.g. for asset management)</li> <li>• equipment information (hardware, options, software, licenses)</li> <li>• system operating status</li> <li>• instrument security information</li> <li>• service related information (due dates etc.)</li> <li>• mass storage related information</li> <li>• instrument utilization data</li> <li>• device history (event log)</li> </ul>

<sup>22</sup> For details see application note under: [www.rohde-schwarz.com/appnote/GFM336](http://www.rohde-schwarz.com/appnote/GFM336)

<sup>23</sup> For use with common available asset management tools.

## General data

Temperature loading		in line with IEC 60068-2-1 and IEC 60068-2-2
	operating temperature range	+5 °C to +40 °C
	storage temperature range	-20 °C to +60 °C
Damp heat		+40 °C at 85 % rel. humidity, in line with IEC 60068-2-30
Maximum operating altitude	above sea level	4600 m (approx. 15100 feet)
Mechanical resistance	vibration, sinusoidal	5 Hz to 55 Hz, 0.15 mm constant amplitude, 55 Hz to 150 Hz, 0.5 g constant, in line with IEC 60068-2-6
	vibration, random	10 Hz to 300 Hz, acceleration 1.2 g (RMS), in line with IEC 60068-2-64
	shock	40 g shock spectrum, in line with MIL-STD-810E, method no. 516.4, procedure I
Calibration interval		1 year
EMC	RF emission	in line with CISPR 11/EN 55011 group 1 class A (for a shielded test setup); instrument complies with the emission requirements stipulated by EN 55011 and EN 61326-1 class A; This means that the instrument is suitable for use in industrial environments.
	immunity	in line with EMC Directive 2014/30/EU, including: IEC/EN 61326-1 (immunity test requirements for industrial environments, EN 61326 table 2), IEC/EN 61326-2-1, IEC/EN 61000-3-2, IEC/EN 61000-3-3
Safety		in line with IEC 61010-1, EN 61010-1 and UL 61010-1, CSA C22.2 61010-1
Power supply		100 V to 240 V at 50 Hz to 60 Hz and 400 Hz, max. 7.3 A to 4.6 A (respectively)
Power consumption	2-port model	≤ 450 W (specification), 300 W (typ.)
	4-port model	≤ 550 W (specification), 350 W (typ.)
Conformity marking		VDE, cCSA <sub>US</sub> , CE, KCC conformity mark
Dimensions	W x H x D	EIA RU1: 6 <sup>24</sup> , 461.4 mm x 284.6 mm x 462.1 mm (18.2 in x 11.2 in x 18.2 in)
Weight	2-port models	24 kg (52.9 lb)
	4-port models	29 kg (63.9 lb)
Shipping weight	2-port models	30 kg (66.2 lb)
	4-port models	35 kg (77.2 lb)

<sup>24</sup> Electronics Industry Association rack units. 1 RU = 1.75 in.

## Dimensions (in mm)

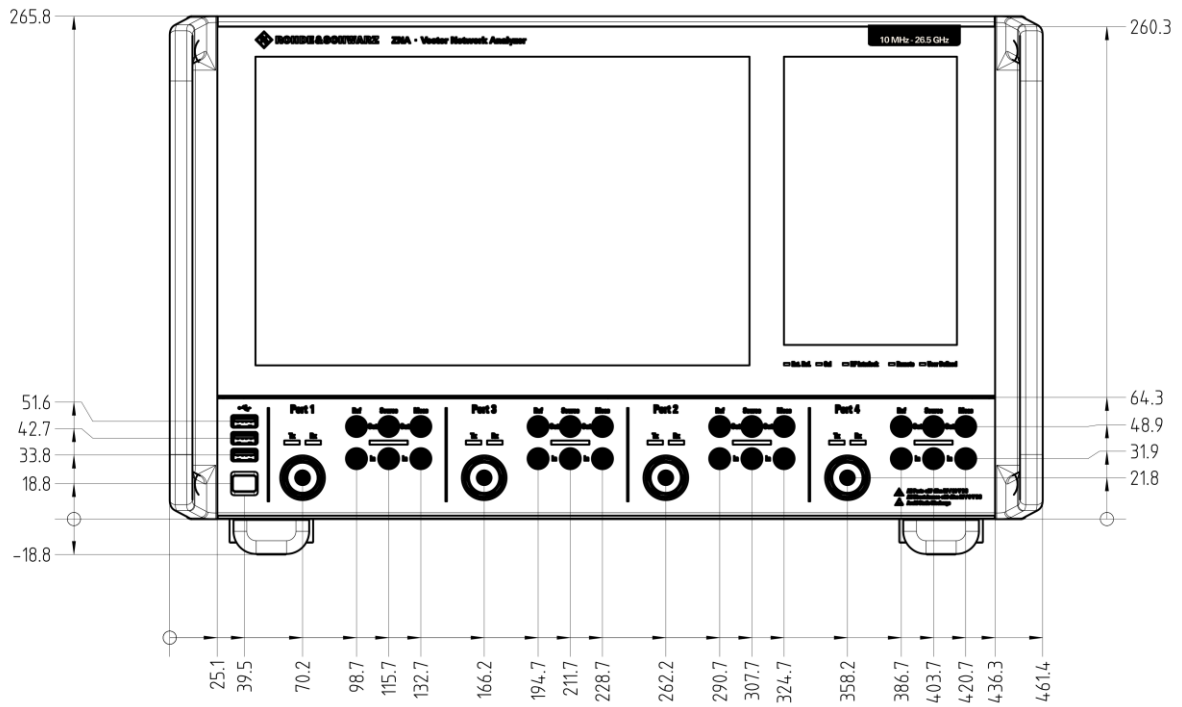

Front view of the R&S®ZNA

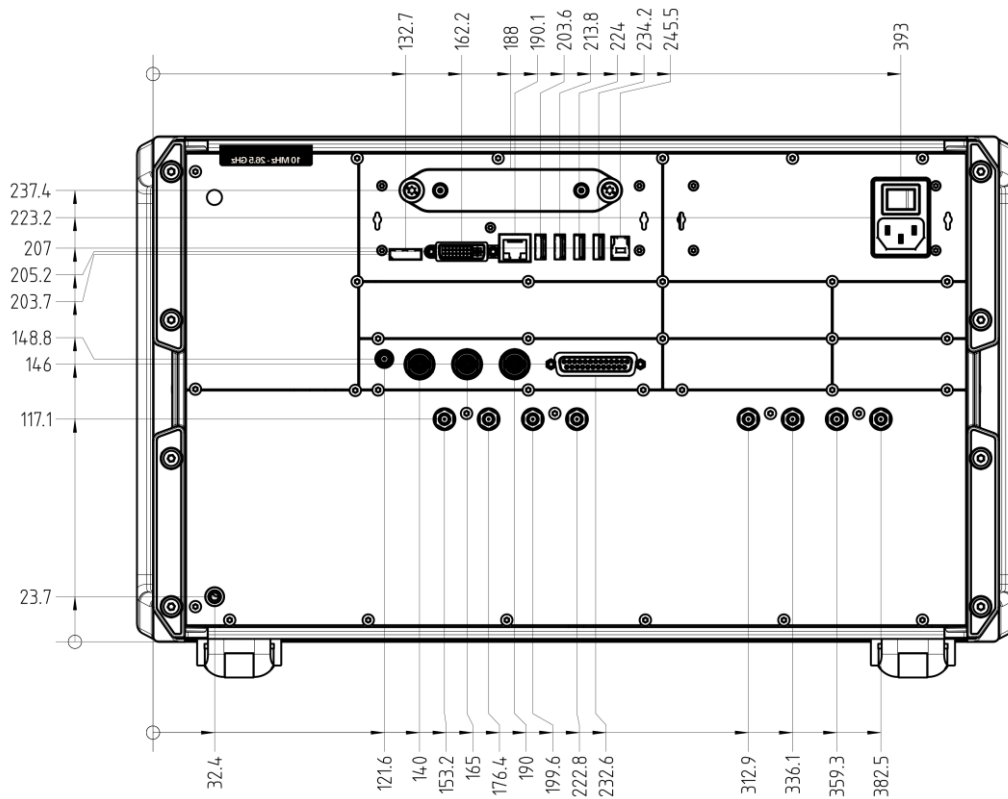

Rear view of the R&S®ZNA

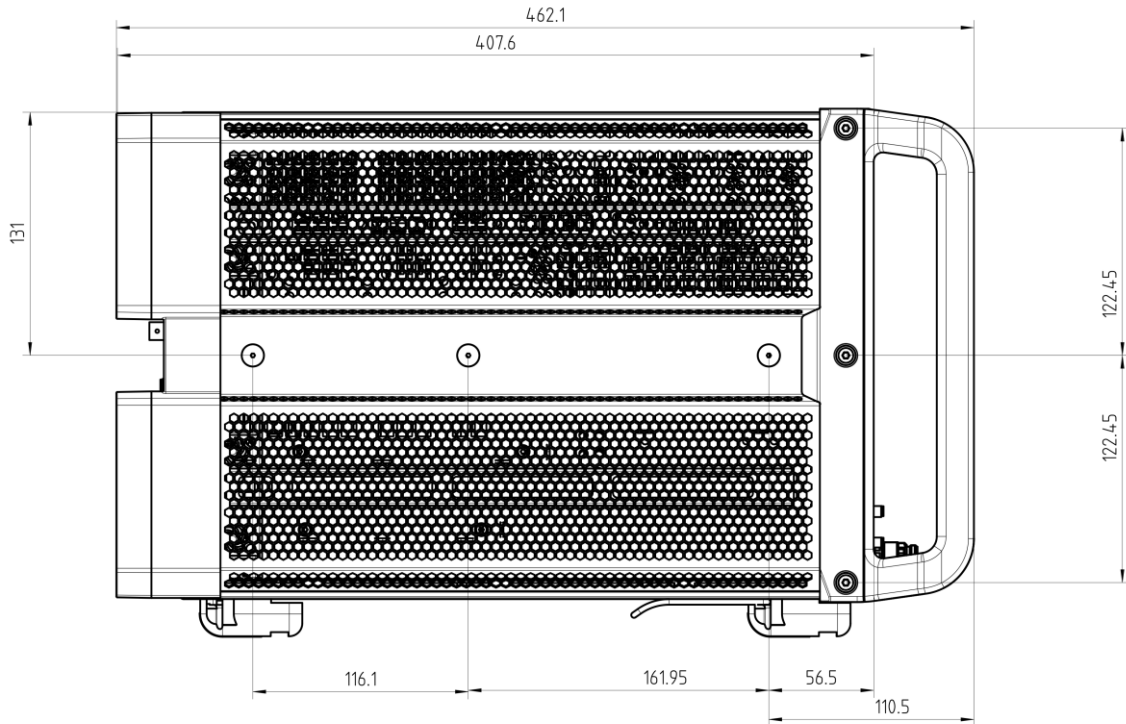

Side view of the R&S<sup>®</sup>ZNA

## Ordering information

Designation	Type	Requires	Service center upgrade <sup>25</sup>	On-site upgrade <sup>26</sup>	Order No.
<b>Base unit</b>					
Vector network analyzer, 2 ports, 26.5 GHz, 3.5 mm connectors	R&S®ZNA26				1332.4500.22
Vector network analyzer, 4 ports, 26.5 GHz, 3.5 mm connectors	R&S®ZNA26				1332.4500.24
Vector network analyzer, 2 ports, 43.5 GHz, 2.92 mm connectors	R&S®ZNA43				1332.4500.42
Vector network analyzer, 4 ports, 43.5 GHz, 2.92 mm connectors	R&S®ZNA43				1332.4500.44
Vector network analyzer, 2 ports, 43.5 GHz, 2.4 mm connectors	R&S®ZNA43				1332.4500.43
Vector network analyzer, 4 ports, 43.5 GHz, 2.4 mm connectors	R&S®ZNA43				1332.4500.45
Vector network analyzer, 2 ports, 50 GHz, 2.4 mm connectors	R&S®ZNA50				1332.4500.52
Vector network analyzer, 4 ports, 50 GHz, 2.4 mm connectors	R&S®ZNA50				1332.4500.54
Vector network analyzer, 2 ports, 67 GHz, 1.85 mm connectors	R&S®ZNA67				1332.4500.62
Vector network analyzer, 4 ports, 67 GHz, 1.85 mm connectors	R&S®ZNA67				1332.4500.64
<b>Options</b>					
Direct source and receiver access, for R&S®ZNA26	R&S®ZNA26-B16	2-port model	yes (U)		1332.4581.22
	R&S®ZNA26-B16	4-port model	yes (U)		1332.4581.24
Direct source and receiver access, for R&S®ZNA43	R&S®ZNA43-B16	2-port model	yes (U)		1332.4581.42
	R&S®ZNA43-B16	4-port model	yes (U)		1332.4581.44
Direct source and receiver access, for R&S®ZNA50	R&S®ZNA50-B16	2-port model	yes (U)		1332.6278.52
	R&S®ZNA50-B16	4-port model	yes (U)		1332.6278.54
Direct source and receiver access, for R&S®ZNA67	R&S®ZNA67-B16	2-port model	yes (U)		1332.6278.62
	R&S®ZNA67-B16	4-port model	yes (U)		1332.6278.64
Source step attenuator, for R&S®ZNA26					
Port 1	R&S®ZNA26-B21		yes (U)		1332.4630.21
Port 2	R&S®ZNA26-B22		yes (U)		1332.4630.22
Port 3	R&S®ZNA26-B23		yes (U)		1332.4630.23
Port 4	R&S®ZNA26-B24		yes (U)		1332.4630.24
Source step attenuator, for R&S®ZNA43					
Port 1	R&S®ZNA43-B21		yes (U)		1332.4646.21
Port 2	R&S®ZNA43-B22		yes (U)		1332.4646.22
Port 3	R&S®ZNA43-B23		yes (U)		1332.4646.23
Port 4	R&S®ZNA43-B24		yes (U)		1332.4646.24
Source step attenuator, for R&S®ZNA50					
Port 1	R&S®ZNA50-B21		yes (U)		1332.5188.21
Port 2	R&S®ZNA50-B22		yes (U)		1332.5188.22
Port 3	R&S®ZNA50-B23		yes (U)		1332.5188.23
Port 4	R&S®ZNA50-B24		yes (U)		1332.5188.24
Source step attenuator, for R&S®ZNA67					
Port 1	R&S®ZNA67-B21		yes (U)		1332.5194.21
Port 2	R&S®ZNA67-B22		yes (U)		1332.5194.22
Port 3	R&S®ZNA67-B23		yes (U)		1332.5194.23
Port 4	R&S®ZNA67-B24		yes (U)		1332.5194.24
Receiver step attenuator, for R&S®ZNA26					
Port 1	R&S®ZNA26-B31		yes (U)		1332.4700.31
Port 2	R&S®ZNA26-B32		yes (U)		1332.4700.32
Port 3	R&S®ZNA26-B33		yes (U)		1332.4700.33
Port 4	R&S®ZNA26-B34		yes (U)		1332.4700.34

<sup>25</sup> Option may also be ordered at a later date; upgrade by Rohde & Schwarz service center. For upgrades, please order the designated U option instead of the B option.

<sup>26</sup> Option may be installed by the user on site.

Designation	Type	Requires	Service center upgrade <sup>25</sup>	On-site upgrade <sup>26</sup>	Order No.
Receiver step attenuator, for R&S®ZNA43					
Port 1	R&S®ZNA43-B31		yes (U)		1332.4717.31
Port 2	R&S®ZNA43-B32		yes (U)		1332.4717.32
Port 3	R&S®ZNA43-B33		yes (U)		1332.4717.33
Port 4	R&S®ZNA43-B34		yes (U)		1332.4717.34
Receiver step attenuator, for R&S®ZNA50					
Port 1	R&S®ZNA50-B31		yes (U)		1332.5165.31
Port 2	R&S®ZNA50-B32		yes (U)		1332.5165.32
Port 3	R&S®ZNA50-B33		yes (U)		1332.5165.33
Port 4	R&S®ZNA50-B34		yes (U)		1332.5165.34
Receiver step attenuator, for R&S®ZNA67					
Port 1	R&S®ZNA67-B31		yes (U)		1332.5171.31
Port 2	R&S®ZNA67-B32		yes (U)		1332.5171.32
Port 3	R&S®ZNA67-B33		yes (U)		1332.5171.33
Port 4	R&S®ZNA67-B34		yes (U)		1332.5171.34
Internal pulse modulator, for R&S®ZNA26					
Port 1	R&S®ZNA26-B41		yes	yes	1332.4775.41
Port 2	R&S®ZNA26-B42		yes	yes	1332.4775.42
Port 3	R&S®ZNA26-B43		yes	yes	1332.4775.43
Port 4	R&S®ZNA26-B44		yes	yes	1332.4775.44
Internal pulse modulator, for R&S®ZNA43					
Port 1	R&S®ZNA43-B41		yes	yes	1332.4781.41
Port 2	R&S®ZNA43-B42		yes	yes	1332.4781.42
Port 3	R&S®ZNA43-B43		yes	yes	1332.4781.43
Port 4	R&S®ZNA43-B44		yes	yes	1332.4781.44
Internal pulse modulator, for R&S®ZNA50					
Port 1	R&S®ZNA50-B41		yes	yes	1332.5088.41
Port 2	R&S®ZNA50-B42		yes	yes	1332.5088.42
Port 3	R&S®ZNA50-B43		yes	yes	1332.5088.43
Port 4	R&S®ZNA50-B44		yes	yes	1332.5088.44
Internal pulse modulator, for R&S®ZNA67					
Port 1	R&S®ZNA67-B41		yes	yes	1332.5094.41
Port 2	R&S®ZNA67-B42		yes	yes	1332.5094.42
Port 3	R&S®ZNA67-B43		yes	yes	1332.5094.43
Port 4	R&S®ZNA67-B44		yes	yes	1332.5094.44
3rd and 4th internal source, for R&S®ZNA26	R&S®ZNA26-B3	4-port model	yes		1332.4523.02
3rd and 4th internal source, for R&S®ZNA43	R&S®ZNA43-B3	4-port model	yes		1332.4617.02
3rd and 4th internal source, for R&S®ZNA50	R&S®ZNA50-B3	4-port model	yes		1332.4981.02
3rd and 4th internal source, for R&S®ZNA67	R&S®ZNA67-B3	4-port model	yes		1332.4998.02
Source monitor access port 1, for R&S®ZNA26	R&S®ZNA26-B161	2-port model, 4-port model	only 2-port model (U)		1332.4823.51
Source monitor access port 1 and port 3, for R&S®ZNA26	R&S®ZNA26-B163	4-port model	yes (U)		1332.4823.53
Source monitor access port 1, for R&S®ZNA43	R&S®ZNA43-B161	2-port model, 4-port model	only 2-port model (U)		1332.4830.51
Source monitor access port 1 and port 3, for R&S®ZNA43	R&S®ZNA43-B163	4-port model	yes (U)		1332.4830.53
Low-noise amplifier port 2, for R&S®ZNA26	R&S®ZNA26-B302	R&S®ZNA26-B16 and R&S®ZNA26-B32	yes		1332.4752.12
Low-noise amplifier port 2, for R&S®ZNA43	R&S®ZNA43-B302	R&S®ZNA43-B16 and R&S®ZNA43-B32	yes		1332.4769.22
Low-power spurious reduction port 1, for R&S®ZNA26	R&S®ZNA26-B501	R&S®ZNA26-B16, R&S®ZNA26-B31 and R&S®ZNA26-B16x	yes		1332.5220.11
Low-power spurious reduction port 1, for R&S®ZNA43	R&S®ZNA43-B501	R&S®ZNA43-B16, R&S®ZNA43-B31 and R&S®ZNA43-B16x	yes		1332.5236.11

Designation	Type	Requires	Service center upgrade <sup>25</sup>	On-site upgrade <sup>26</sup>	Order No.
Internal combiner port 1 and port 2, for R&S®ZNA26	R&S®ZNA26-B212	2-port model, R&S®ZNA26-B52, R&S®ZNA26-B21 and R&S®ZNA26-B22	yes		1332.5265.02
Internal combiner port 1 and port 2, for R&S®ZNA43	R&S®ZNA43-B212	2-port model, R&S®ZNA43-B52, R&S®ZNA43-B21 and R&S®ZNA43-B22	yes		1332.5271.02
Internal combiner port 1 and port 3, for R&S®ZNA26	R&S®ZNA26-B213	4-port model, R&S®ZNA26-B21 and R&S®ZNA26-B23	yes		1332.4846.13
Internal combiner port 1 and port 3, for R&S®ZNA43	R&S®ZNA43-B213	4-port model, R&S®ZNA43-B21 and R&S®ZNA43-B23	yes		1332.4869.13
Precision frequency reference (OCXO)	R&S®ZNA-B4		yes		1332.4530.02
2nd internal LO source	R&S®ZNA-B5	4-port model	yes	yes	1332.4675.02
2nd internal source and LO, for R&S®ZNA26	R&S®ZNA26-B52	2-port model	yes		1332.6503.02
2nd internal source and LO, for R&S®ZNA43	R&S®ZNA43-B52	2-port model	yes		1332.6510.02
2nd internal source and LO, for R&S®ZNA50	R&S®ZNA50-B52	2-port model	yes		1332.6526.02
2nd internal source and LO, for R&S®ZNA67	R&S®ZNA67-B52	2-port model	yes		1332.6532.02
Data streaming memory	R&S®ZNA-B7		yes		1332.4546.02
mmWave converter LO	R&S®ZNA-B8	2-port model: R&S®ZNA-B26; 4-port model: R&S®ZNA-B26 or R&S®ZNA-B5	yes		1332.4652.02
RFFE GPIO interface	R&S®ZNA-B15		yes		1332.4575.02
RFFE GPIO interface, including voltage/current measurement	R&S®ZNA-B15		yes		1332.4575.03
Additional removable hard disk	R&S®ZNA-B19				1332.4600.02
Direct IF access	R&S®ZNA-B26		yes	yes	1332.4598.02
Trigger and control I/O board	R&S®ZNA-B91		yes		1332.4800.02
Spectrum analyzer mode	R&S®ZNA-K1		yes	yes	1332.5320.02
Time domain analysis (TDR)	R&S®ZNA-K2		yes	yes	1332.5336.02
Extended time domain analysis (including eye diagram)	R&S®ZNA-K20	R&S®ZNA-K2	yes	yes	1332.4746.02
Scalar mixer measurements, arbitrary frequency-converting measurements	R&S®ZNA-K4		yes	yes	1332.5342.02
Vector mixer measurements	R&S®ZNA-K5	see Options section for recommended setup	yes	yes	1332.5359.02
Phase coherent source control	R&S®ZNA-K6		yes	yes	1332.5413.02
True differential mode	R&S®ZNA-K61		yes	yes	1332.5442.02
Measurements on pulsed signals	R&S®ZNA-K7	R&S®ZNA-K17 together with pulse modulator <sup>27</sup>	yes	yes	1332.5371.02
Increased IF bandwidth 30 MHz	R&S®ZNA-K17		yes	yes	1332.5459.02
mmWave converter support	R&S®ZNA-K8	see Options section for recommended setup	yes	yes	1332.5388.02
Group delay measurements on frequency converters without LO access	R&S®ZNA-K9	see Options section for recommended setup	yes	yes	1332.5394.02
1 mHz frequency resolution	R&S®ZNA-K19		yes	yes	1332.5513.02
Continuous data recording	R&S®ZNA-K28		yes	yes	1332.5613.02
Noise figure measurement	R&S®ZNA-K30	see Options section for recommended setup	yes	yes	1332.5465.02

<sup>27</sup> R&S®ZNAxx-B41/-B42/-B43/-B44, and/or R&S®ZNA-B91 (control of external pulse modulator). R&S®ZNA-B7 is recommended.

Designation	Type	Requires	Service center upgrade <sup>25</sup>	On-site upgrade <sup>26</sup>	Order No.
Uncertainty analysis	R&S®ZNA-K50		yes	yes	1332.5542.02
Uncertainty analysis, preinstalled	R&S®ZNA-K50P				1332.5594.02
Security write protection	R&S®ZNA-K51				1332.5559.02
Easy deembedding	R&S®ZNA-K210		yes	yes	1339.3897.02
In-situ deembedding	R&S®ZNA-K220		yes		1339.3900.02
Smart fixture deembedding	R&S®ZNA-K230		yes		1339.3916.02
Delta-L PCB characterization	R&S®ZNA-K231		yes		1339.3922.02
Health and utilization monitoring service	R&S®ZNA-K980		yes	yes	1332.5607.02

Designation	Type	Order No.
<b>Recommended calibration and verification accessories</b>		
<b>Calibration kits (manual calibration)</b>		
Calibration kit, 3.5 mm, 50 Ω, 0 Hz to 26.5 GHz	R&S®ZN-Z235	1336.8500.02
Calibration kit, 2.92 mm, 50 Ω, 0 Hz to 43.5 GHz	R&S®ZN-Z229	1336.7004.02
Calibration kit, 2.4 mm, 50 Ω, 0 Hz to 50.0 GHz	R&S®ZN-Z224	1339.5002.02
Calibration kit, 1.85 mm, 50 Ω, 0 Hz to 67.0 GHz	R&S®ZN-Z218	1337.3502.02
Calibration kit, 1.0 mm, 50 Ω, 0 Hz to 110 GHz	R&S®ZV-Z210	5011.6588.02
<b>Calibration units (automatic calibration)</b>		
Calibration unit, 9 kHz to 26.5 GHz, 2 ports, 3.5 mm (f)	R&S®ZN-Z50	1335.6904.32
Calibration unit, 100 kHz to 26.5 GHz, 4 ports, 3.5 mm (f)	R&S®ZN-Z52	1335.7046.30
Calibration unit, 100 kHz to 26.5 GHz, 2 ports, 3.5 mm (f)	R&S®ZN-Z53	1335.7046.32
Calibration unit, 9 kHz to 40 GHz, 2 ports, 2.92 mm (f), characterized to 43.5 GHz	R&S®ZN-Z54	1335.7117.92
Calibration unit, 9 kHz to 50 GHz, 2 ports, 2.4 mm (f)	R&S®ZN-Z55	1335.7181.42
Calibration unit, 5 GHz to 67 GHz, 2 ports, 1.85 mm (f)	R&S®ZN-Z156	1332.7239.02
<b>Inline calibration units (automatic calibration)</b>		
Inline calibration unit controller	R&S®ZN-Z30	1328.7609.02
Inline calibration unit 40 GHz, characterized to 43.5 GHz	R&S®ZN-Z33	1328.7644.02
Inline calibration unit 40 GHz TVAC, characterized to 43.5 GHz	R&S®ZN-Z33	1328.7644.03
<b>Verification kits</b>		
Verification kit, 3.5 mm, 45 MHz to 26.5 GHz	R&S®ZV-Z435	1319.1060.02
Verification kit, 45 MHz to 40.0 GHz, 2.92 mm	R&S®ZV-Z429	1319.1076.02
Verification kit, 45 MHz to 50.0 GHz, 2.4 mm	R&S®ZV-Z424	1319.1082.02
<b>Test cables</b>		
3.5 mm (f) to 3.5 mm (m), 0 Hz to 26.5 GHz, length: 0.6 m/1 m	R&S®ZV-Z93	1301.7595.25/ 1301.7595.38
2.92 mm (f) to 2.92 mm (m), 0 Hz to 40 GHz, length: 0.6 m/1 m	R&S®ZV-Z95	1301.7608.25/ 1301.7608.38
2.4 mm (f) to 2.4 mm (m), 0 Hz to 50 GHz, length: 0.6 m	R&S®ZV-Z97	1301.7637.25
3.5 mm (f) to 3.5 mm (m), 0 Hz to 26.5 GHz, length: 0.6 m/0.9 m/1.5 m	R&S®ZV-Z193	1306.4520.24/ 1306.4520.36/ 1306.4520.60
2.92 mm (f) to 2.92 mm (m), 0 Hz to 40 GHz, length: 0.6 m/0.9 m	R&S®ZV-Z195	1306.4536.24/ 1306.4536.36
1.85 mm (f) to 1.85 mm (m), 0 Hz to 67 GHz, length: 0.6 m/0.9 m	R&S®ZV-Z196	1306.4559.24/ 1306.4559.36
<b>Hardware add-ons</b>		
Calibration mixer, 2.92 mm (f), 10 GHz to 40 GHz	R&S®ZN-ZM292	1339.3800.02
2-way power divider, 40 GHz	R&S®ZN-Z1229	3691.8162.02
4-way power divider, 40 GHz	R&S®ZN-Z1230	3691.8179.02
Millimeterwave adaption kit, for R&S®ZNA26/43, two converters	R&S®ZCAKN	1332.6178.43
Millimeterwave adaption kit, for R&S®ZNA26/43, four converters	R&S®ZCAKN	1332.6178.44
Millimeterwave adaption kit, for R&S®ZNA50/67, two converters	R&S®ZCAKN	1332.6178.67
Millimeterwave adaption kit, for R&S®ZNA50/67, four converters	R&S®ZCAKN	1332.6178.68
Torque wrench, for 3.5/2.92/2.4/1.85 mm connector, 8 mm width, 0.9 Nm torque	R&S®ZTW	1328.8534.35
Torque wrench, for R&S®ZNA test port connector, 19 mm width, 0.9 Nm torque	R&S®ZTW	1328.8534.19
19" rack adapter	R&S®ZZA-KN6	1175.3056.00
Cable set, for R&S®ZNA-K9 (3.5 mm for R&S®ZNA26)	R&S®ZNA26-Z9	1332.4730.26
Cable set, for R&S®ZNA-K9 (2.92 mm for R&S®ZNA43)	R&S®ZNA43-Z9	1332.4730.43
Cable set, for R&S®ZNA-K9 (2.4 mm for R&S®ZNA43)	R&S®ZNA43-Z9	1332.4730.44
Cable set, for R&S®ZNA-K9 (1.85 mm for R&S®ZNA50)	R&S®ZNA50-Z9	1332.4730.50
Cable set, for R&S®ZNA-K9 (1.85 mm for R&S®ZNA67)	R&S®ZNA67-Z9	1332.4730.67



<b>Warranty</b>		
Base unit		3 years
All other items <sup>29</sup>		1 year
<b>Service options</b>		
Extended warranty, one year	R&S <sup>®</sup> WE1	Please contact your local Rohde & Schwarz sales office.
Extended warranty, two years	R&S <sup>®</sup> WE2	
Extended warranty with calibration coverage, one year	R&S <sup>®</sup> CW1	
Extended warranty with calibration coverage, two years	R&S <sup>®</sup> CW2	
Extended warranty with accredited calibration coverage, one year	R&S <sup>®</sup> AW1	
Extended warranty with accredited calibration coverage, two years	R&S <sup>®</sup> AW2	

#### **Extended warranty with a term of one and two years (WE1 and WE2)**

Repairs carried out during the contract term are free of charge <sup>30</sup>. Necessary calibration and adjustments carried out during repairs are also covered.

#### **Extended warranty with calibration coverage (CW1 and CW2)**

Enhance your extended warranty by adding calibration coverage at a package price. This package ensures that your Rohde & Schwarz product is regularly calibrated, inspected and maintained during the term of the contract. It includes all repairs <sup>30</sup> and calibration at the recommended intervals as well as any calibration carried out during repairs or option upgrades.

#### **Extended warranty with accredited calibration (AW1 and AW2)**

Enhance your extended warranty by adding accredited calibration coverage at a package price. This package ensures that your Rohde & Schwarz product is regularly calibrated under accreditation, inspected and maintained during the term of the contract. It includes all repairs <sup>30</sup> and accredited calibration at the recommended intervals as well as any accredited calibration carried out during repairs or option upgrades.

<sup>29</sup> For options installed, the remaining base unit warranty applies if longer than 1 year. Exception: all batteries have a 1 year warranty.

<sup>30</sup> Excluding defects caused by incorrect operation or handling and force majeure. Wear-and-tear parts are not included.





## Service that adds value

- ▶ Worldwide
- ▶ Local and personalized
- ▶ Customized and flexible
- ▶ Uncompromising quality
- ▶ Long-term dependability

## Rohde & Schwarz

The Rohde&Schwarz technology group is among the trail-blazers when it comes to paving the way for a safer and connected world with its leading solutions in test & measurement, technology systems and networks&cybersecurity. Founded more than 85 years ago, the group is a reliable partner for industry and government customers around the globe. The independent company is headquartered in Munich, Germany and has an extensive sales and service network with locations in more than 70 countries.

[www.rohde-schwarz.com](http://www.rohde-schwarz.com)

## Sustainable product design

- ▶ Environmental compatibility and eco-footprint
- ▶ Energy efficiency and low emissions
- ▶ Longevity and optimized total cost of ownership

Certified Quality Management

ISO 9001

Certified Environmental Management

ISO 14001

## Rohde & Schwarz training

[www.training.rohde-schwarz.com](http://www.training.rohde-schwarz.com)

## Rohde & Schwarz customer support

[www.rohde-schwarz.com/support](http://www.rohde-schwarz.com/support)

