

IEC 625 Bus

NOISE GENERATOR SUF 2

20 Hz to 50 MHz

Noise spectra for
measurements in accordance with CCIR and CCITT recommendations
and for general-purpose measurements

NOISE GENERATOR SUF 2

SUF 2

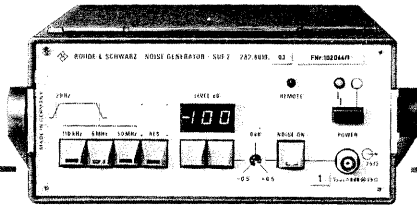

- Noise level 0 to -100 dB (-80 dB up to 50 MHz); reference level 0 dB = $1 \text{ V}/0.775 \text{ V}/0.7 \text{ V}$ into 75Ω
- White noise in three frequency ranges up to 50 MHz
- Coloured noise with plug-in filters for internationally recommended test methods
- Can be remote-controlled for use in automatic test systems

Characteristics and uses

The low-priced **Noise Generator SUF 2** delivers a high noise power up to 50 MHz which can be reduced down to the μV range with the aid of the built-in attenuator. A three-digit readout displays the selected level value in dB relative to the internally link-selected reference value ($1 \text{ V}/0.775 \text{ V}/0.7 \text{ V}$).

The three **frequency ranges** for white noise (20 Hz to 110 kHz/6 MHz/50 MHz) and a fourth range covered by a plug-in (optional) filter board producing the noise spectrum for pink noise, triangular noise or sound-program noise permit virtually any noise measurement to be performed.

The different ways to control all the instrument functions, such as the parallel remote control of the basic model, programming via an IEC-625 bus interface (option) or periodic level switching with link-selected time and level values (option) extend the instrument's application range to automatic test systems.

In **audio engineering**, noise signals are required for simulating speech/music. Compared with single-frequency measurements, the noise-signal method yields more meaningful values (however, selective voltmeters or analyzers must be used). Moreover, suitably shaped noise spectra are indispensable as program replacement signals for internationally recommended test methods in accordance with CCIR and CCITT.

In **frequency-division multiplex systems**, noise can be used to closely mimic the program signal on one or several adjacent channels.

In **video engineering**, the measurement of the noise rejection in circuit components, such as sync separators or clamping circuits, is of interest; in digital TV systems, it is particularly the bit error rate of the different types of coding which is tested.

RF engineering often requires rapid, approximate measurements on IF filters in TV and FM-sound modules or radio equipment up to 50 MHz.

Description

Noise signal generation. The noise source is the avalanche-discharge base-emitter junction of a temperature-controlled RF transistor with a special chip geometry. After frequency-response correction a noise spectrum with constant energy and Gaussian amplitude distribution (white noise) is obtained in the range from 20 Hz to 50 MHz. All the amplifiers in the signal path are

designed for an output swing of up to seven times the maximum rms value.

Switch-selected filters limit the 50-MHz-wide noise spectrum to 6 MHz or 110 kHz. In addition to these three signal paths, a fourth path can be fitted with an active filter for "coloured" noise. The subsequent power amplifier boosts the noise level, permits fine level adjustment to within $\pm 0.5 \text{ dB}$ and controls the mean signal value. The $75\text{-}\Omega$ attenuator consists of seven attenuator networks set in binary steps enabling level adjustment in 1-dB steps. Two additional attenuator networks permit the maximum output voltage of 1 V_{rms} to be reduced to the usual reference level of 0.775 V (= 0 dBm) for audio-frequency measurements or 0.7 V for video-frequency measurements.

Operation. In the **manual mode**, all the settings can be entered using the buttons on the clearly arranged front panel and are displayed immediately.

Using TTL levels, a **parallel remote control facility** permits all the functions to be set. After data entry a transfer pulse causes the desired values to be set. Two additional control lines switch the noise signal on and off.

The **IEC-625-Bus Interface Option SUF 2-Z1** is available to allow the SUF 2 to be used in computer-controlled test systems. Each setting command consists of the figures for the filter number or level value followed by an identification letter. Two additional commands switch the noise signal on and off. In accordance with IEC 625-1, the ISO 7-bit code (ASCII) is used for data transfer; the interface operates as a pure listener (L1).

The **CCIR Rec. 571 Program Option SUF 2-Z6** periodically switches between two programmable levels and the "noise off" status. The filters and the time intervals can be selected as well. The instrument is factory-set for intermodulation measurements in accordance with CCIR Rec. 571, the noise spectrum being shaped with the aid of the associated Filter SUF 2-Z5.

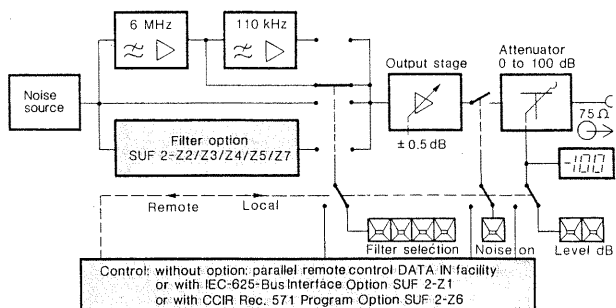

Block diagram of SUF 2

Measurements using white noise

Frequency response measurement (up to 50 MHz)

The analyzer directly indicates the frequency response of the test item.



Analog frequency-division multiplex systems

A superimposed noise signal enables determination of the maximum permissible noise in stereo broadcast and telephone (international baseband) systems.

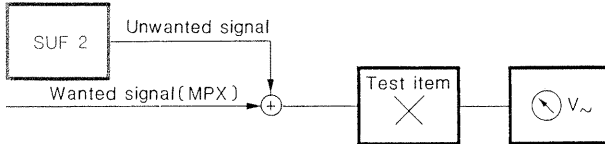

Measurements in acoustics

Unwanted resonances and level dips, as well as how uniform the radiation of high and low frequencies is, can be measured with the aid of a test microphone.

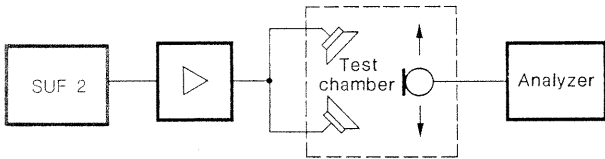

Harmonic distortion measurements in multi-channel systems

The white noise simulates a number of speech signals (1), arranged next to each other. Due to nonlinear distortion in the test item, spurious signals (3) appear in the gap (2) whose frequency range is filtered out at the input. The signal/noise ratio (4) is determined by means of a selective voltmeter; with the noise source switched off, the inherent noise of the test item can be measured by a further measurement and thus eliminated.

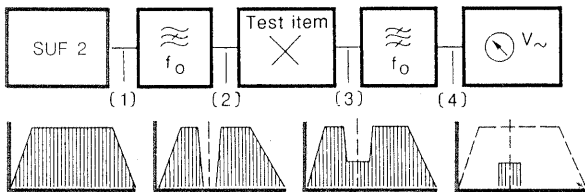

Noise rejection in clamping circuits, sync separators, etc.

By gradually increasing the superimposed noise, it is possible to determine the threshold up to which signal processing remains unaffected.

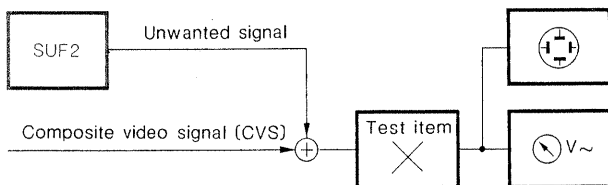

Noise rejection in digital transmission systems

The bit error rate can be measured, and thus the performance of error-correction codes can be determined, by varying the quality of the input signal to the device under test.

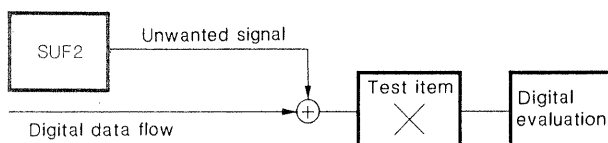

Measurements using "coloured" noise

Triangular noise 0 to 6 MHz - Option SUF 2-Z2

This signal corresponds to the noise produced in the wanted channel in FM transmission systems (radio links, satellite communications). Thus items under test can be measured under conditions coming close to practical operation without requiring transmission equipment.

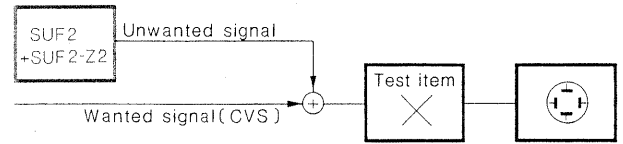

Pink noise 20 Hz to 16 kHz - Option SUF 2-Z3

The constant energy content of this signal per octave permits rapid frequency response measurements using one-third-octave or octave filters (e.g. PBT or PBO).

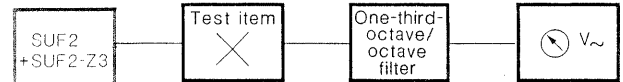

Program replacement signal to CCIR Rec. 559 - Option SUF 2-Z4

This signal, for AM systems operating in the long, medium and short wave ranges, is used to measure the signal/noise ratio and the intermodulation between adjacent channels. It represents the statistically determined spectral distribution of "modern dance music".

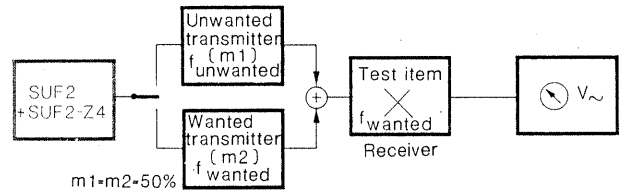

Program replacement signal to CCIR Rec. 571 - Option SUF 2-Z5

This signal featuring the spectral distribution of a "conventional program signal" is used mainly for measurements in frequency-division multiplex systems.

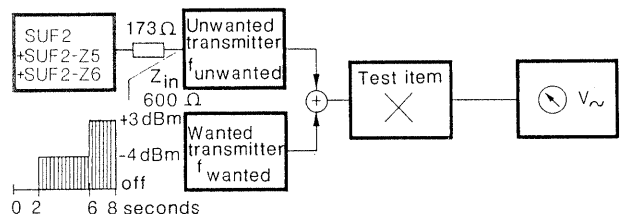

Replacement signal to CCITT Rec. G. 227 - Option SUF 2-Z7

This standardized telephony signal is used to measure crosstalk on unused channels.



Automatic Test Systems

By fitting the Option IEC-625-Bus Interface SUF 2-Z1, the SUF 2 becomes suitable for inclusion in test systems where all the measuring instruments and the test item itself are under program control.

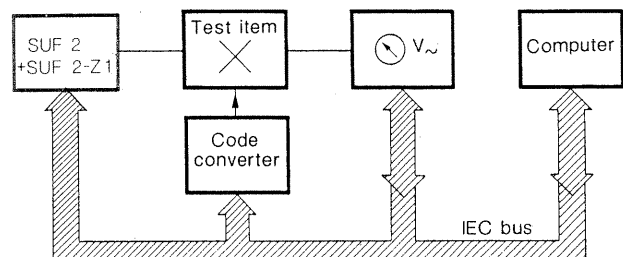

NOISE GENERATOR SUF 2

Specifications

Noise spectrum

Filter bandwidth, switch-selected .. 20 Hz to 110 kHz
20 Hz to 6 MHz
20 Hz to 50 MHz

Filter options one only can be inserted;
SUF 2-Z2/-Z3/-Z4/-Z5/-Z7
see below

Noise level

Maximum level, link-selected 1 V_{rms} into 75 Ω (standard)
0.775 V_{rms} into 75 Ω (audio)
0.7 V into 75 Ω (video)

Setting range 1-dB steps;
0 to -80 dB (20 Hz to 50 MHz)
0 to -100 dB (remaining ranges)

Fine adjustment approx. ±0.5 dB (cannot be
remote-controlled)

Frequency response flatness < 1 dB (ripple)

Level error < 1 dB

Clock period for level variation approx. 0.3 s per 1-dB step
(approx. 30 ms/dB with the
button held down)

Output BNC female connector

Operation

Manual by means of buttons on front
panel

Remote-controlled (standard) parallel TTL control signals;
level: BCD code + transfer pulse
filter: binary code + transfer pulse
noise: on/off

Remote-control options one only can be inserted;
SUF 2-Z1 or SUF 2-Z6, see below

Filter Options SUF 2-Z2/-Z3/-Z4/-Z5/-Z7 (these specifications in common)

Construction plug-in PCB

Gain full gain compensation,
exchangeable without calibration
see diagrams

Frequency response see diagrams

IEC-625-Bus Interface Option SUF 2-Z1

Interface standard IEC 625-1 (IEEE-488)

Connector 24-way, Amphenol

Interface functions AH1: acceptor handshake
L1: listener
RL1: remote/local

Local operation in system

configuration with "rtl" (return to local) switch

Character standard ISO 7-bit code (ASCII)

Timing approx. 0.2 ms for addressing
approx. 0.2 ms for data transfer

CCIR Rec. 571 Program Option SUF 2-Z6

Cycle run automatic, programmable
two levels and "noise off"
plus: the filter type can be link-
selected

Level values 4 s: -7 dB
2 s: 0 dB
2 s: noise off

Standard timing cycle duration: 8 s

Nominal 0-dB level if the audio reference output level
has been set, the recommended
test level of +3 dBm into 600 Ω
can be obtained by a series
resistor of 173 Ω

General data

Rated temperature range +5 to +45 °C

Storage temperature range -20 to +75 °C

AC supply 115/125/220/235 V +10/-15%,
47 to 63 Hz (20 VA)

Overall dimensions (without
stand; W x H x D) and weight 210 mm x 110 mm x 347 mm, 4 kg

Ordering information

Order designation Noise Generator SUF 2
282.8819.03

Accessories supplied power cord, manual

Recommended extras

Filter options:

Triangular Noise SUF 2-Z2 282.9715.00

Pink Noise SUF 2-Z3 282.9815.00

CCIR Rec. 559 Filter SUF 2-Z4 282.9615.00

CCIR Rec. 571 Filter SUF 2-Z5 282.9644.00

CCITT Rec. G. 227 Filter SUF 2-Z7 282.8860.00

Remote-control options:

IEC-625-Bus Interface SUF 2-Z1 282.9915.00

CCIR Rec. 571 Program SUF 2-Z6 282.9673.00

Filter options

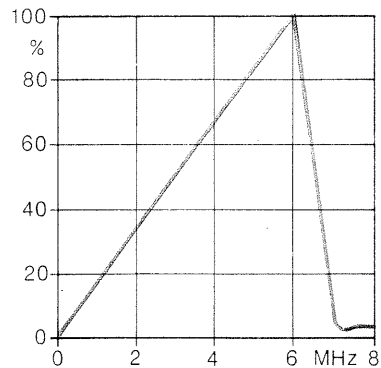

Triangular Noise
Option SUF 2-Z2

Used for:
measurements on
video equipment
when simulating
FM transmission
systems,
radio links and
satellite
communication
equipment

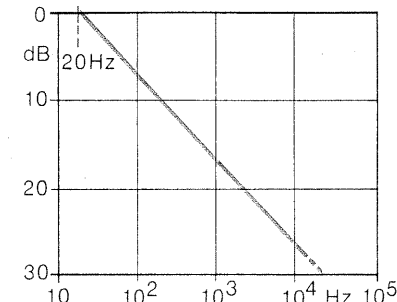

Pink Noise
Option SUF 2-Z3

Used for:
rapid frequency
response measure-
ments
using one-third-
octave
and octave filters

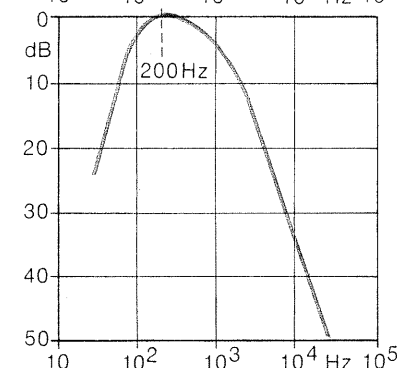

**CCIR Rec. 559
Filter**
Option SUF 2-Z4

Used for:
"modern dance
music"
replacement signal
for long, medium and
short wave
systems (9-kHz
channel
spacing, AM)

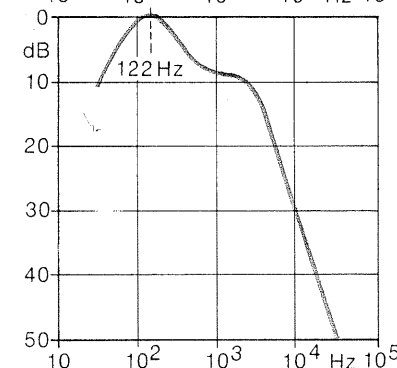

**CCIR Rec. 571
Filter**
Option SUF 2-Z5

Used for:
"conventional
program"
replacement signal
for frequency-division
multiplex systems
(FM)

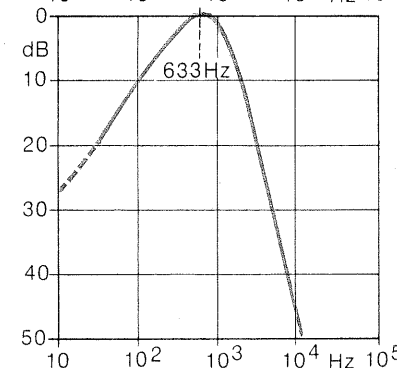

**CCITT Rec. G. 227
Filter**
Option SUF 2-Z7

Used for:
speech replacement
signal
for telephony