

Voltech

PM6000

Power Analyzer



A New Standard in Power Analysis

- Up to 6 wattmeter channels
- Basic accuracy: 0.02% of reading
- Bandwidth: 10MHz
- Easy-to-use in all applications

The Voltech PM6000 Power Analyzer



New generation power analyzer PM6000 has the power to provide:

- Up to 6 wattmeter channels
- 0.02% basic accuracy for definitive power loss and efficiency measurements
- Sampling at 40MHz (5MHz minimum) for error-free results
- Outstanding rejection of common-mode signals for accuracy in all applications
- A bright color display and intuitive menu system for ease of use
- Connectivity: RS232, Printer, Ethernet, USB* (*Future Release)

Versatile, accurate, fully-featured and yet easy-to-use

The PM6000 provides definitive measurements of all electrical power quantities on all products that consume, convert or generate electrical power. The Voltech PM6000 combines years of power measurement know-how with the latest digital signal processing technology to provide a unique combination of measurement and reporting features that will solve power measurement problems.

Why the PM6000? There is a constant consumer and legislative pressure to design electrical products that are more efficient, power electronics designers use more and more sophisticated control methods and increases in switching frequency to achieve this. Therefore more sophisticated, more accurate and higher bandwidth power measurements are required to validate and test power electronic designs.

The PM6000 has been designed especially to meet the needs of today's design and test engineers by providing greater flexibility and bandwidth at high accuracy.

Measurements

The PM6000 is an advanced digital sampling power analyzer. From 1 to 6 measurement channels may be fitted to a PM6000. Each measuring channel is a separate wattmeter with fully floating inputs for connection to the voltage and current of the power circuit to be measured.

Voltages up to 2000 Vpk may be connected directly to the measurements channels and a wide variety of current transducers may be used, including wide-bandwidth resistive current shunts from Voltech. The Voltech shunts plug directly into the measurement channel for convenience, and have the advantage that the shunt's calibration data is automatically transferred to the PM6000, providing optimum accuracy for the complete measurement path. For other external current transducers, each channel can supply $\pm 12V$ DC power. Unique and proprietary algorithms are then used to process the samples and provide stable and accurate measurements in all applications.

Measurements include:	
W	Real or True Power in Watts
Vrms	True rms Voltage
Arms	True rms Amps
Freq	Frequency
PF	Power Factor
VA	Apparent Power
VAr	Reactive Volt-Amperes
f	Fundamental or 1st harmonic
Harm	Harmonics of power, volts and amps
THD	Total Harmonic Distortion (with options for different formulae)
Pk	Voltage and current peak
CF	Voltage and current crest factor (pk / rms)
Z	Impedance
Vrmn	Rectified mean voltage
Arm n	Rectified mean current
Max / Min	Holds Maximum and Minimum values Ideal for Inrush testing
Math	The math menu can be used to calculate efficiency from channel to channel or to make complex calculations such as transformer k factors
Integrator	For W-h consumption of electrical appliances and low-power standby measurements
Datalog	Log of all measurements to memory, optional hard disk or floppy in a spreadsheet compatible file

Set-Up and Control

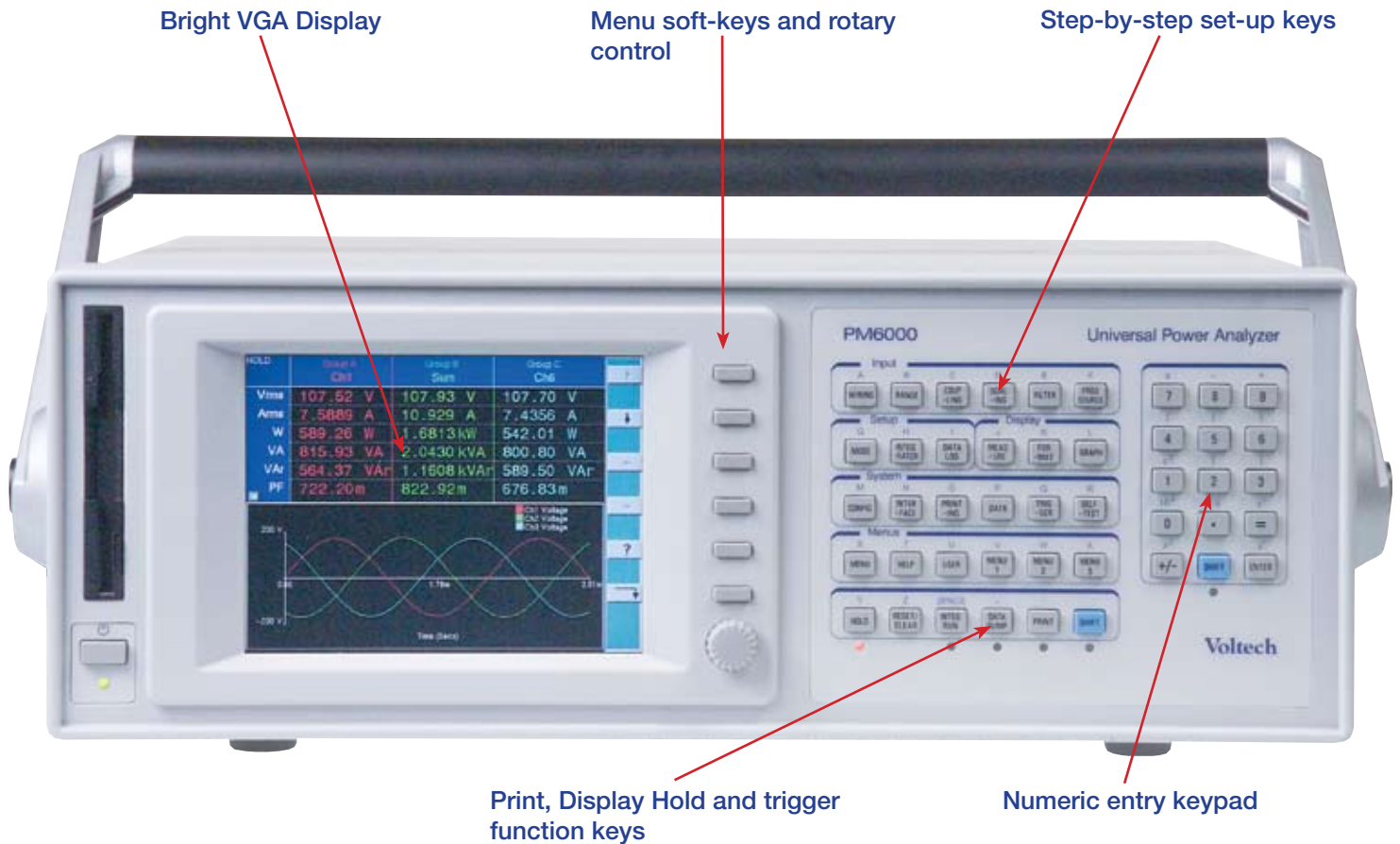

Front Panel

The intuitive menu system will guide you through the set-up and control of the analyzer. Working through the options step-by-step allows you to configure channels into groups for a variety of multi-phase connections, to set scaling for external voltage and current transducers, and to choose the required measurements.

Rear Panel

At the rear, comprehensive control is provided via RS232. Standard printers may be connected directly for local print-out of numeric results. The ethernet port allows for powerful control and datalogging to a network drive.

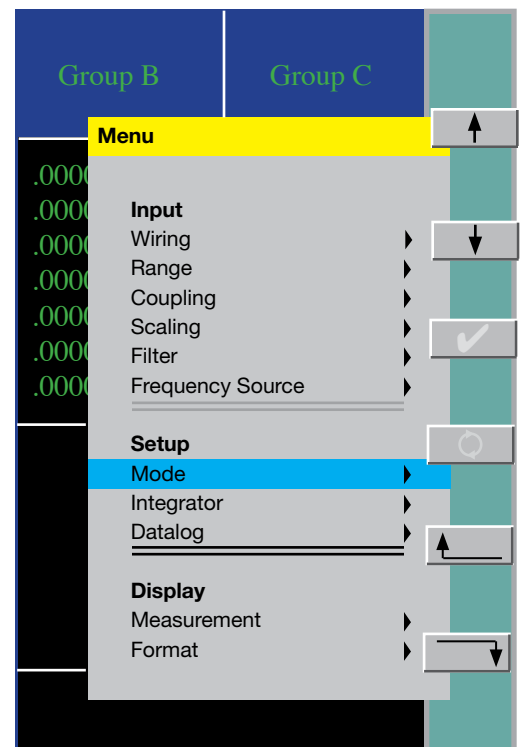

Applications - Power Supplies

Ideal for measurements on power supplies, from wall chargers to UPS and high-power converters, the PM6000 makes accurate measurements on all waveforms including those heavily distorted by the rectification and smoothing at power supply inputs.

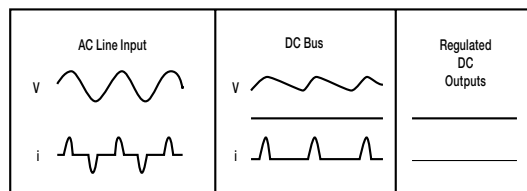
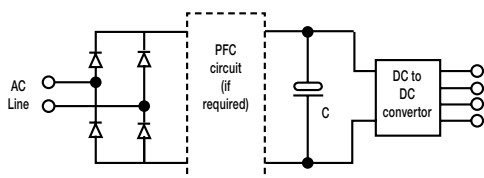
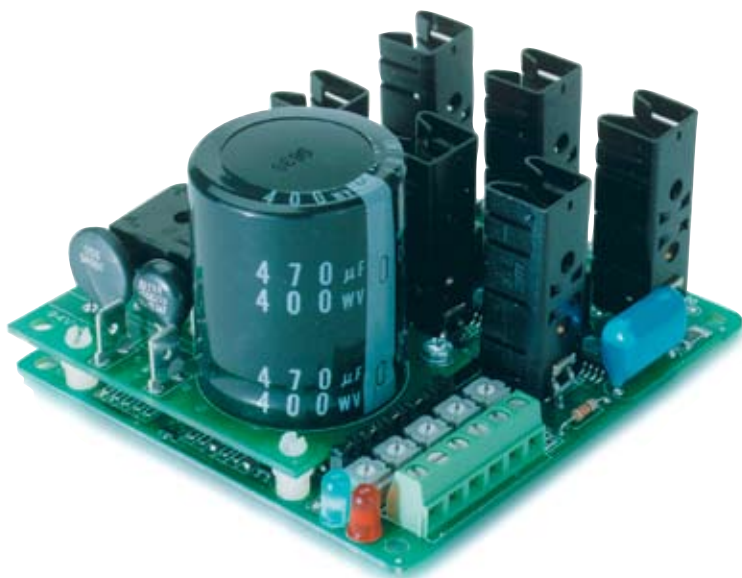

Measurements	
W	Input and Output power
Math	Input to output efficiency
Vrms	Line regulation, drop-out voltage, testing power fail circuits
Arms	Conductor and fuse rating
VA	Apparent power for supply rating
Apk MAX	Inrush Current Verification of inrush limiting circuit design Qualified fuse rating
PF	Power Factor (W/ VA) for verification of power factor control circuits
A harm	Amps harmonics for testing to IEC61000-3-2 and other harmonic standards
A THD V THD	Distortion of input current Distortion of supply or AC output
Integrator	Low-power standby measurements

Advantages

- Up to six channels configurable as required, for example AC input plus 5 DC outputs or three-phase input and output.
- Excellent 0.02% basic accuracy - useful for high efficiency measurements.
- Accurate on all waveforms.
- Samples continuously, without gaps at 5 MSPS so there is no missing data during integration or low-power standby measurements.

Applications - Power Transformers

Power transformers are characterized under open-circuit and short-circuit conditions. Open-circuit, the power factor of the transformer is close to zero (<0.01), which demands very low phase error, from the power analyzer. The analog design of the PM6000 ensures that its voltage and current channels are carefully matched, providing optimum performance at low power factors.

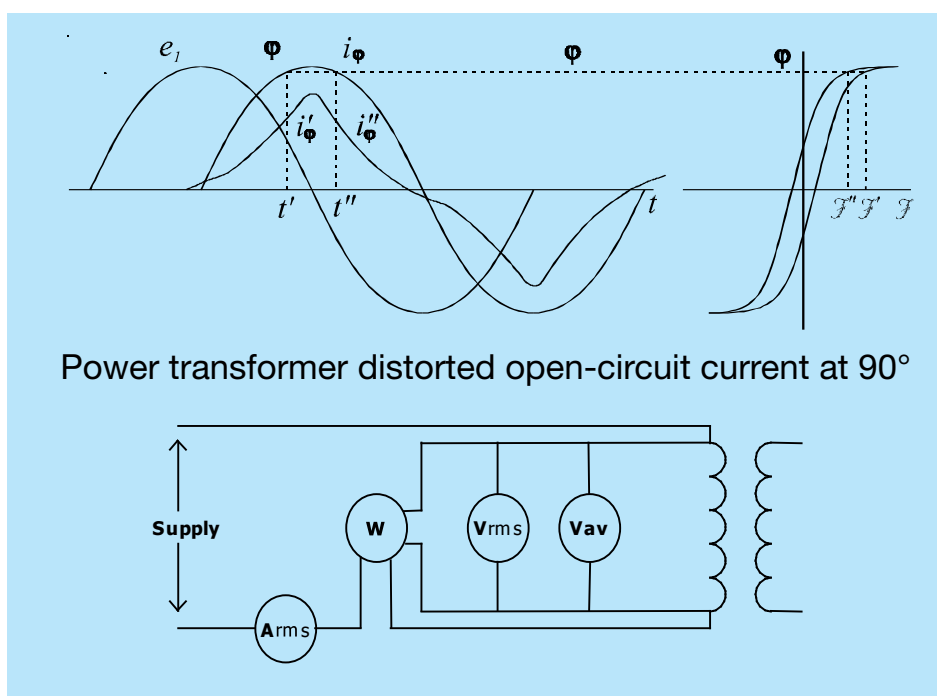

Power transformer distorted open-circuit current at 90°

Measurements

Watts, V_{rms} , V_{rmin} , A_{rms} , VA, VAR, Apk, Harmonics, THD, Inrush.
K-factor and corrected power to IEEE and IEC standards.

Advantages

- Up to six channels for simultaneous three-phase input and output – Star (Wye) or Delta connection.
- Accurate at low power factors. (<0.01)
- Simultaneous measurement of rms and mean voltage as required by IEC76 and IEEE57.
- Measure turns ratio directly using the math function.

Applications – Variable Frequency Drives and Machines

The versatile PM6000 will make simultaneous measurements at the input and output of a drive, allowing accurate efficiency measurements under all load and speed conditions.

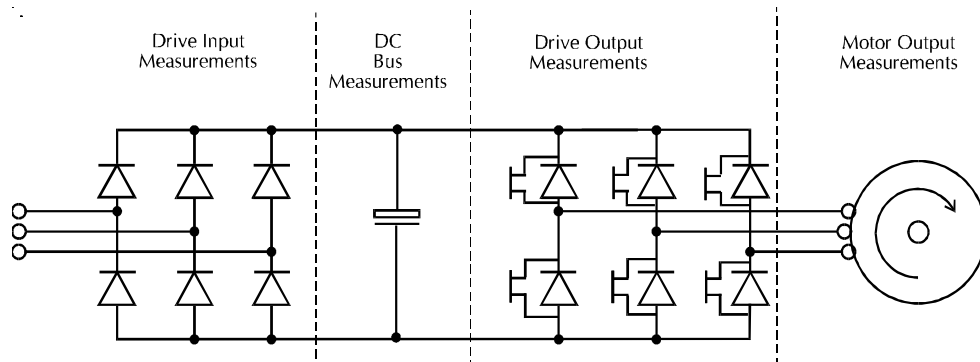

Measurements

Drive Input	DC Bus	Drive Output	Motor Output	Efficiency Measurements
W, V, A, VA, Pk, Harmonics THD, Inrush.	W, V, A DC Voltage, AC ripple voltage.	W, V, A, PF, Fundamental W, V, A, Harmonics	Torque and Speed.	Efficiency of each section of PWM drive, motor efficiency and overall efficiency.

Advantages

- Up to six channels configurable as required, for example 3 wattmeter, three-phase input, DC bus and two-wattmeter drive output and torque and speed measured simultaneously.
- Excellent 0.02% basic accuracy - useful for high efficiency measurements.
- 10MHz bandwidth captures all motor frequency and high-frequency data for the most accurate overall power measurement.
- High rejection of common-mode signals found on the drive output. 140dB @ 60Hz, 95dB@1Mhz

Applications - Power Integration / Standby

The power consumption of everyday home and office electrical appliances is of importance to consumers and generators of electricity alike.



IEC 62301



When the power consumption varies over time, then integration of the power (W-h integration) is required. The PM6000 provides comprehensive integration features suitable for Energy Star measurements and for low-power measurements in accordance with international directives, eg. IEC 62301 which also requires crest factor measurements up to 8 and 50 harmonics.

Measurements

W	Input power
W-h	Power integrated over programmable time
Vrms	Drop-out voltage, testing power fail circuits
Arms	Conductor and fuse rating
A-h	For battery back-up charge and discharge
VA	Apparent power for supply rating
VA-h	Apparent power integrated over programmable time
Apk MAX	Inrush Current Verification of inrush limiting circuit design. Qualify fuse rating.
PF	Power Factor (W/ VA) for verification of power factor control circuits
A harm	Amps harmonics for testing to IEC61000-3-2 and other harmonic standards
A THD	Distortion of input current
V THD	Distortion of supply or AC output
Crest Factor	$\left(\frac{\text{Peak}}{\text{RMS}}\right)$ I. or V. Up to 20 - Best in the industry

Advantages

- Excellent 0.02% basic accuracy - useful for high efficiency measurements.
- Accurate on all waveforms.
- Samples continuously, without gaps at 5 MSPS so there is no missing data during integration or low-power standby measurements.
- Versatile current channel input for low – current measurements. 1A Voltech plug-in shunt available.

Applications - IEC Harmonics and Flicker

Voltech continues to be a leader in producing power analyzers that meet the ever changing needs of today's world. A mandatory measurement for products in Europe and many other countries, the IEC standards define specific methods for testing current harmonics and flicker

(voltage changes). The PM6000 and its easy-to-use software provide design engineers and EMC test laboratories with a comprehensive suite of measurements and reports that fully comply with the latest standards.



	Measurements
Harmonics:	<p>To IEC61000-3-2 and IEC61000-4-7 (including inter-harmonic grouping)</p> <p>40 current harmonics, 40 voltage harmonics, watts, power factor, voltage crest factor and frequency.</p> <p>Total Harmonic Content (THC) and Partial Odd Harmonic Content (POHC).</p> <p>Window width: 10 cycles @ 50Hz, 12 cycles @ 60Hz</p> <p>Automatic limit checking for classes A, B, C and D.</p>
Flicker:	<p>To IEC61000-3-3 and IEC61000-4-15</p> <p>Pst and Plt dc, dmax and dt Manual switching dmax</p>

Advantages.

- Full compliance testing for EMC laboratories when used with an AC Source and Impedance Network.
- Superb pre-compliance measurements when used stand-alone.
- PC software plays back previous tests and generates reports suitable for technical construction files.
- Discrete Fourier Transform (DFT) 'reference instrument' implementation avoids the problems of Fast Fourier Transform (FFT) analyzers.
- Solutions for harmonics and flicker to 75A.

Applications - Lighting Ballasts

To measure the efficiency of a high-frequency ballast, it's essential to have an accurate measurement of both the input and output power of the ballast. With unbeatable accuracy at both low and high frequencies, and superior common-mode rejection, the PM6000 will make the most accurate efficiency measurements possible.

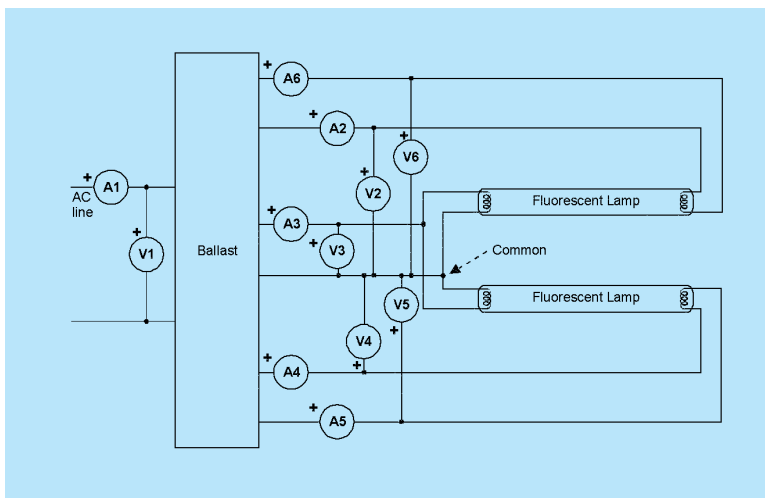

Measurements

- Input and Output W, V, A, PF.
- Efficiency of the ballast.
- Inrush current
- Switching frequency harmonics and THD

Advantages

- Up to six channels configurable as required. Single channel input and five channels in the example above.
- Excellent 0.02% basic accuracy - useful for high efficiency measurements
- 10MHz bandwidth captures all the line frequency and high-frequency data for the most accurate overall power measurement.
- High rejection of common-mode signals found on the ballast output.
- Special ballast mode locks the analyzer to the line frequency to provide stable and reliable full-bandwidth data.
- Easy to set up - no need to set filters or sample rate. All done automatically in Ballast mode.

Accessories

**PM6000 Back Panel
with 6 channels
and 3 Voltech
30A shunts
fitted.**



Clamp-on Current Transformers



- Accuracy better than 1%
- Connect to the PM6000 via safety leads and 1A shunt
- CL100 100A:1A
- CL1000 1000A:1A

CT1000 –Dual Ratio Precision Current Transformer

- Accuracy ($23^{\circ}\text{C} \pm 5^{\circ}\text{C}$): $\pm 0.2\%$ of specified ratio
- Frequency range: 45Hz to 1kHz
- Current range: 100:1 ratio: 10A to 120A rms 1000:1 ratio: 100A to 1200A rms
- Maximum input current: 1000A continuous 2000A for 1 hour
- Phase error ($23^{\circ}\text{C} \pm 5^{\circ}\text{C}$): Better than $\pm 0.1^{\circ}$ at 50Hz



PS1000 - Inrush Switch



Solid-state switch for energizing loads (up to 200Apk) at either the peak or the zero crossing of AC voltage. Ideal for inrush current testing.

Ballast CT

Purposely designed for lighting applications, this device overcomes problems that are usually found when using conventional or Hall effect CTs.

- Convenient: No need to feed cables through a CT core.
- Better than 1% accuracy: Trifilar wound toroidal core.
- 5kHz to 1MHz bandwidth .
- 5mA to 1A measurement range



Ordering

PM6000 Chassis

With color VGA display and 3½" floppy drive.
Connectivity: RS232, Printer, Ethernet, USB*
(*Future Release)

Hard Disk Drive (Optional)

PM6000 Measurement Channel

High performance wattmeter channel. Voltage 1500V,
Current 2.5V for shunt or current transducer. ±12V
DC supply for external current transducer.

1A Shunt

1A rms, 5Apk precision measuring shunt with
calibration stored in EEPROM. (Bandwidth 10MHz)

30A shunt

30A rms, 200Apk precision measuring shunt with
calibration stored in EEPROM. (Bandwidth 1MHz)

Lead set

2 pairs (yellow and black) 1.5m, 2000V, 30A leads
with safety connectors and alligator clips.

Specifications

Voltage

$$\text{Magnitude}(V) = 0.02\% \text{rdg} + 0.05\% \text{rng} + (0.001\% \times F) \text{rdg} + 20 \text{mV}$$

$$\text{Phase}(\text{°}) = 0.005 + \left[0.0003 \times \frac{V_{\text{rng}}}{V} \right] + \frac{0.05}{V} + (0.001 \times F)$$

Current

$$\text{Magnitude}(A) = 0.02\% \text{rdg} + 0.05\% \text{rng} + (0.001\% \times F) \text{rdg} + \frac{20 \mu V}{Z_{\text{EXT}}}$$

$$\text{Phase}(\text{°}) = 0.0025 + \left[0.0005 \times \frac{I_{\text{rng}}}{I} \right] + \frac{0.00004}{I \times Z_{\text{EXT}}} + (0.0006 \times F)$$

Power

$$\text{Error}(\text{Watts}) = \left[\frac{V_{\text{RMS error}}}{V_{\text{RMS}}} + \frac{A_{\text{RMS error}}}{A_{\text{RMS}}} + \left(\tan \theta \times (Vh1_{\text{Ph error}} + Ah1_{\text{Ph error}}) \times \frac{\pi}{180} \right) \right] \times W$$

1. At 23°C ± 5°C, valid 1 year from calibration.
2. %rdg = percentage of reading, % rng = percentage of range, F = frequency in kHz.
3. Vrng = Voltage range: 5, 10, 20, 50, 100, 200, 500, 1000, 2000Vpk.
4. Irng = Current range.
30A shunt: 0.5, 1, 2.5, 5, 10, 20, 50, 100, 250Apk.
1A shunt: 0.01, 0.02, 0.05, 0.1, 0.2, 0.5, 1.0, 2.0, 5.0Apk.
Voltage input: 0.005, 0.010, 0.025, 0.05, 0.10, 0.25, 0.50, 1.0, 2.5Vpk.

5. Ø = angle between voltage and current.
6. Zext = 0.01 (30A shunt), 0.5 (1A shunt), 0.0125 (default voltage input) ohms.

Voltech

www.voltech.com

Distributor

Voltech Instruments Inc.
11637 Kelly Road, Suite 306
Fort Myers, FL 33908
USA
Tel: (239) 437 0494
Fax: (239) 437 3841
Email sales@voltech.com

Voltech Instruments Ltd.
148 Harwell Int'l Business Centre
Didcot, Oxon. OX11 0RA
UK
Tel: +44 (0) 1235 834555
Fax: +44 (0) 1235 835016
Email: sales@voltech.co.uk

Voltech has an intensive program of design and development and reserves the right to alter product specification without notice. Although every care has been taken in compiling this information Voltech does not accept any liability for errors or omissions. ©2006 Voltech.

VPN: 86-506/9