

MD8480C

W-CDMA Signalling Tester

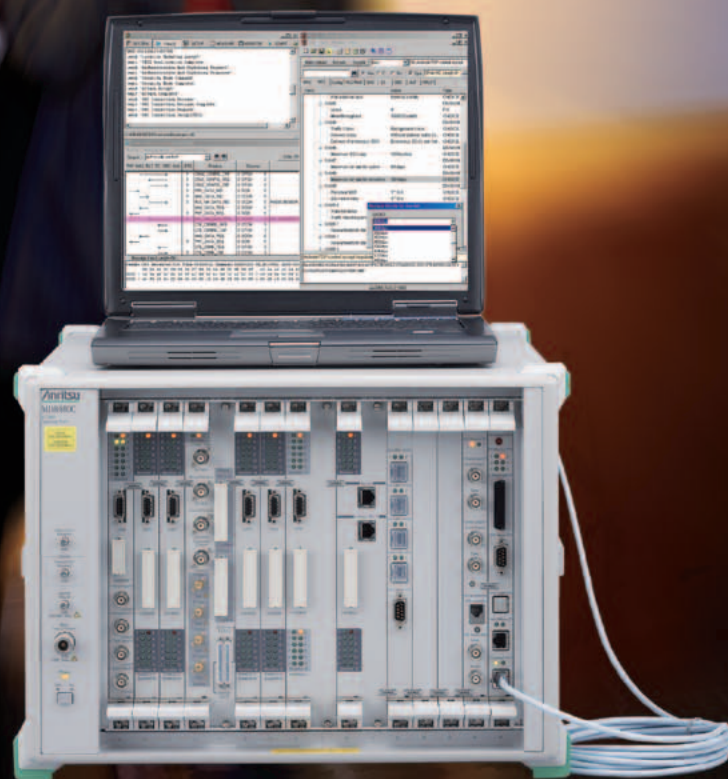

All-in-One Solution for 2G/3G/3.5G Chipset and UE Development

The current worldwide proliferation of 3G mobile services is promoting increasingly high-speed data packet access in the mobile communications environment. W-CDMA-based systems are starting to use HSPA Evolution*1 to achieve high data transfer speeds while GSM-based systems are using EGPRS*2. Demand for high-speed data services by mobile users worldwide is driving development of mobile terminals (UE) that can secure optimum data throughput under any conditions.

The MD8480C W-CDMA Signalling Tester is a base station simulator with ideal protocol development and test functions for developing 3.5G W-CDMA UE supporting HSPA Evolution. It has an air interface conforming to 3GPP specifications as standard and supports a full range of applications and protocol tests, coding/decoding processing, protocol sequence testing (registration, origination, termination, handover), voice and data communications testing (circuit switch, packet switch), and UE end-to-end testing*3 for chipsets and UE. Moreover, adding options for GSM/GPRS/EGPRS base stations supports Inter-RAT handover tests between 3G/3.5G and 2G systems. The MD8480C is the ideal instrument for developing increasingly popular UMTS UE and high-performance chipsets and UE for HSPA/EGPRS*4.

*1: High Speed Packet Access Evolution

*2: Enhanced GPRS

*3: Requires two MD8480C units

*4: Handover Testing between W-CDMA/HSPA and GSM/EGPRS at Voice/Data Communications

Major Role in Development Cycle

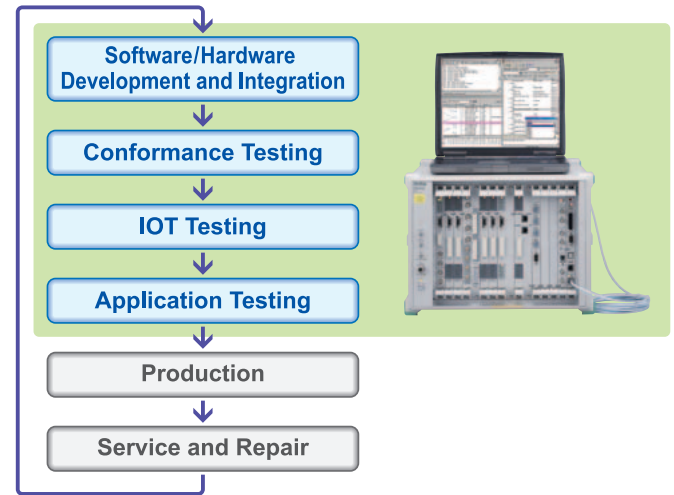

Features

- Supports 3GPP HSPA Evolution
- Full Support for All UE Categories (Release 8)
- Data Throughput Test (DL 42 Mbps/UL 11 Mbps)
- One Unit Supports Expanded Functions for 4 BTS max. (W-CDMA/HSPA)
- Optional GSM/GPRS/EGPRS 2BTS Functions
- Inter-RAT Handover Tests between HSPA and EGPRS

Main Uses

- 3G/3.5G UE Protocol Sequence Tests
- 3G/3.5G UE Coding/Decoding Function Tests (RF/BB)
- Inter/Intra-RAT Handover UE Protocol Sequence Tests
- Inter-RAT HO Packet Data Communications Tests (Ping, FTP, Browsing)
- HSPA/EGPRS Packet Data Communications Tests
- Applications Tests, including Voice and Packet
- Throughput Monitoring Test

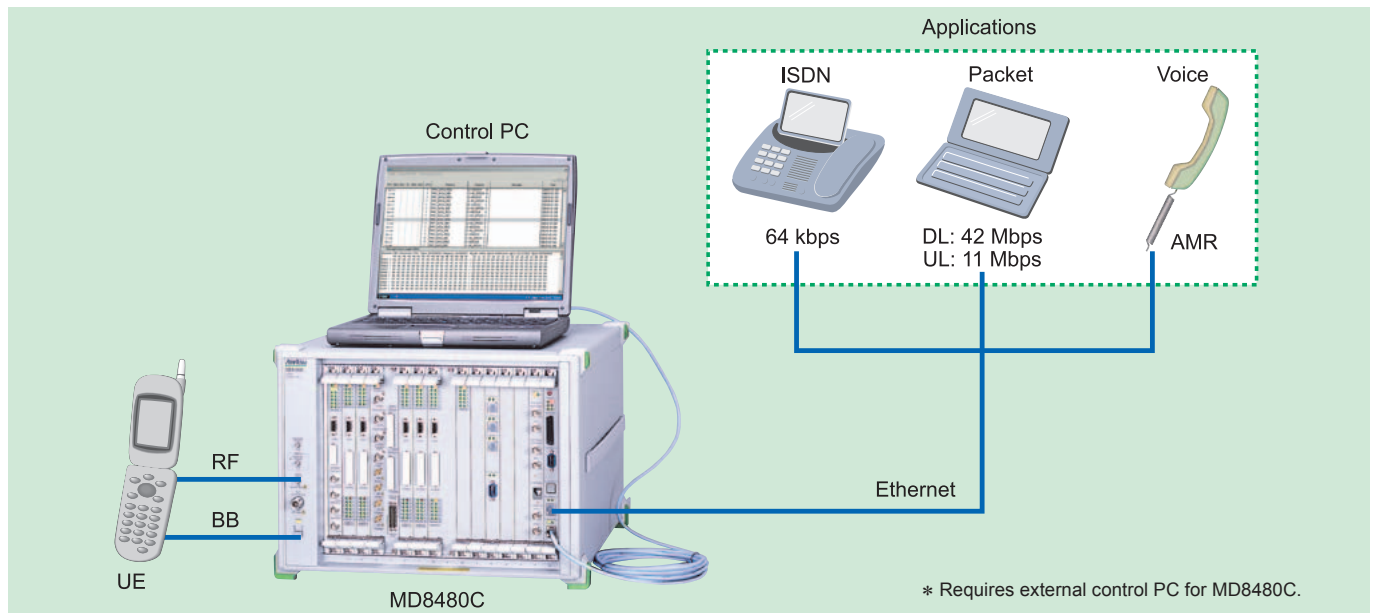

For Developing W-CDMA/HSPA/HSPA Evolution Chipsets and UE

Features

- Supports All UE Categories (Release 8)
- Genuine Maximum Throughput (DL: 42 Mbps/UL: 11 Mbps)
- Diversity Reception Testing using Four Base Stations

Main Uses

- W-CDMA/HSPA UE Protocol Sequence Tests
- W-CDMA/HSPA UE Coding/Decoding Tests (RF/Baseband)
- HSPA Packet Data Throughput Measurement
- Various Function Tests for Voice, Packets, Video Call
- Protocol Conformance, IOT, Field Tests, etc.

Main Test Functions

- W-CDMA/HSPA Handover Tests (SHO/HHO)*1
- Slow Clock and Fading Tests using DBB*2
- L1 to L3 Log Analysis
- Throughput Monitor Function
- Power, Frequency, Timing Monitor Function
- Fading Simulation Function (connects with MF6900A)

*1: SHO: Soft Handover, HHO: Hard Handover

*2: Requires separate Baseband Interface Unit option (MU848077C)

Basic Functions (W-CDMA)

- Downlink (DL) Signal Sending
- Uplink (UL) Signal Receive
- Basic Signalling (Call Processing)
- Inner-loop Power Control (TPC)
- BLER Measurement
- Soft/Hard Handover (Option)
- Tx/Rx Diversity (Option)
- Compressed Mode (Option)
- Ciphering (KASUMI, SNOW 3G, Option)
- 2 × 2 MIMO (Option)
- Baseband Interface (Option)
- AWGN, OCNS Tests
- TE Connection Test (ISDN, AMR, User Data, IP, PPP, MS-to-MS)

Supported Services

- DB-DC-HSDPA (Release 9) (Option)
- 64QAM and MIMO (Option)
- Dual Cell HSDPA (Option)
- HSPA Evolution (Option)
- HSDPA/HSUPA (Option)
- MBMS/W-CDMA CBS
- CS Voice over HSPA (Option)
- IPv6
- A-GPS (RRC, SUPL)

Supports All UE Categories

The MD8480C uses new hardware and signal processing technologies to achieve higher data transfer speeds for HSPA Evolution. By using the HSPA Base Station Function it supports all UE categories meeting the 3GPP TS 25.306 (Release 8) recommendations.

3GPP TS 25.306 (Release 8) Category List HSDPA

HS-DSCH category	Maximum number of HS-DSCH codes received	Minimum inter-TTI interval	Maximum number of bits of an HS-DSCH transport block received within an HS-DSCH TTI	Total number of soft channel bits	Supported modulations without MIMO operation or dual cell operation	Supported modulations simultaneous with MIMO operation and without dual cell operation	Supported modulations with dual cell operation	Maximum Throughput [bits/s]
Category 13	15	1	35280	259200	QPSK, 16QAM, 64QAM	Not Applicable (MIMO not supported)	Not Applicable (dual cell operation not supported)	17,640,000
Category 14	15	1	42192	259200				21,096,000
Category 15	15	1	23370	345600				11,685,000
Category 16	15	1	27952	345600				13,976,000
Category 17	15	1	35280	259200	QPSK, 16QAM, 64QAM	–	Not Applicable (dual cell operation not supported)	17,640,000
			23370	345600	–	QPSK, 16QAM		23,370,000
Category 18	15	1	42192	259200	QPSK, 16QAM, 64QAM	–	Not Applicable (dual cell operation not supported)	21,096,000
			27952	345600	–	QPSK, 16QAM		27,952,000
Category 19	15	1	35280	518400	QPSK, 16QAM, 64QAM		Not Applicable (dual cell operation not supported)	35,280,000
Category 20	15	1	42192	518400	QPSK, 16QAM, 64QAM			42,192,000
Category 21	15	1	23370	345600	–	–	QPSK, 16QAM	23,370,000
Category 22	15	1	27952	345600				27,952,000
Category 23	15	1	35280	518400				35,280,000
Category 24	15	1	42192	518400				42,192,000

HSUPA

E-DCH Category	E-DCH Codes	Minimum Spreading Factor	Support for 10 and 2 ms TTI EDCH	TB-Sizes with 10 ms E-DCH TTI	TB-Sizes with 2 ms E-DCH TTI	Modulations	Maximum Throughput [bps]
Category 1	1	SF4	10 ms TTI only	7110	–	QPSK	711,000
Category 2	2	SF4	10 ms	14484	2798	QPSK	1,448,400
			2 ms				1,399,000
Category 3	2	SF4	10 ms TTI only	14484	–	QPSK	1,448,400
Category 4	2	SF2	10 ms	20000	5772	QPSK	2,000,000
			2 ms				2,886,000
Category 5	2	SF2	10 ms TTI only	20000	–	QPSK	2,000,000
Category 6	4	SF2	10 ms	20000	11484	QPSK	2,000,000
			2 ms				5,742,000
Category 7	4	SF2	10 ms	20000	22996	QPSK, 16QAM	2,000,000
			2 ms				11,498,000

For Developing W-CDMA/HSPA/HSPA Evolution Chipsets and UE

Max. Throughput (DL 42 Mbps/UL 11 Mbps)

The MD8480C HSPA Evolution function supports maximum throughput (DL 42 Mbps/UL 11 Mbps) based on DC-HSDPA, 64QAM + MIMO (Release 8) or DB-DC-HSDPA (Release 9), making the tester ideal for developing chipsets for next-generation high-speed packet data services.

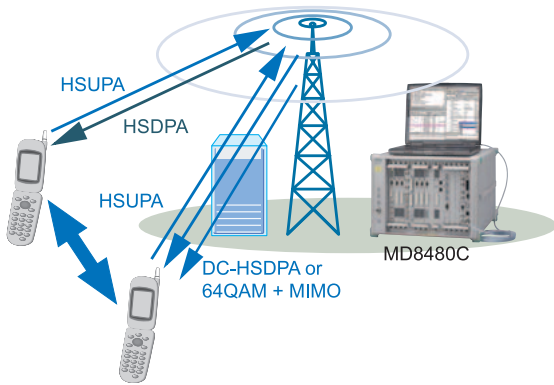
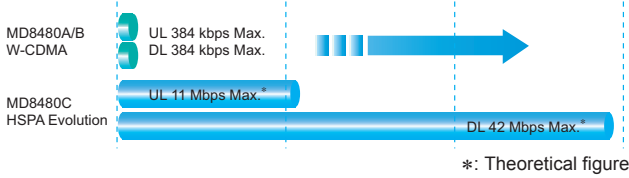

Log Analysis and Throughput Monitoring Functions

The MD8480C has a full line of log analysis and monitoring functions supporting development of HSPA UE that can process data instantaneously in the lower layers. For example, the built-in Measure Counter function monitors the Layer 1/Layer 2 throughput in real time during testing, and the ACK, NACK, DTX, and CQI values are displayed too. In addition, if an abnormality is discovered by testing, the built-in converter software can convert the saved log files for statistical analysis of the HSPA TTI parameters (ACK, NACK, DTX and CQI) every 2 ms using spreadsheet software.

W-CDMA Power				GSM/GPRS				
Channel	8180	8182	8184	8186				
Frequency	2137.6MHz	2137.6MHz	2137.6MHz	2137.6MHz				
Total Power	-30.0 dBm	-33.0 dBm	-33.0 dBm	-33.0 dBm				
P_SCH	-30.0 dBm	-	-	-				
L_SCH	-30.0 dBm	-	-	-				
P_CCH	-30.0 dBm	-	-	-				
L_CCH	-30.0 dBm	-	-	-				
L_CCPCH	-30.0 dBm	-	-	-				
L_CCPCH2	-30.0 dBm	-	-	-				
L_CCPCH3	-30.0 dBm	-	-	-				
L_CCPCH4	-30.0 dBm	-	-	-				
L_CCPCH5	-30.0 dBm	-	-	-				
L_CCPCH6	-30.0 dBm	-	-	-				
L_CCPCH7	-30.0 dBm	-	-	-				
L_CCPCH8	-30.0 dBm	-	-	-				
L_CCPCH9	-30.0 dBm	-	-	-				
L_CCPCH10	-30.0 dBm	-	-	-				
L_CCPCH11	-30.0 dBm	-	-	-				
L_CCPCH12	-30.0 dBm	-	-	-				
L_CCPCH13	-30.0 dBm	-	-	-				
L_CCPCH14	-30.0 dBm	-	-	-				
L_CCPCH15	-30.0 dBm	-	-	-				
L_CCPCH16	-30.0 dBm	-	-	-				
L_CCPCH17	-30.0 dBm	-	-	-				
L_CCPCH18	-30.0 dBm	-	-	-				
L_CCPCH19	-30.0 dBm	-	-	-				
L_CCPCH20	-30.0 dBm	-	-	-				
L_CCPCH21	-30.0 dBm	-	-	-				
L_CCPCH22	-30.0 dBm	-	-	-				
L_CCPCH23	-30.0 dBm	-	-	-				
L_CCPCH24	-30.0 dBm	-	-	-				
L_CCPCH25	-30.0 dBm	-	-	-				
L_CCPCH26	-30.0 dBm	-	-	-				
L_CCPCH27	-30.0 dBm	-	-	-				
L_CCPCH28	-30.0 dBm	-	-	-				
L_CCPCH29	-30.0 dBm	-	-	-				
L_CCPCH30	-30.0 dBm	-	-	-				
L_CCPCH31	-30.0 dBm	-	-	-				
L_CCPCH32	-30.0 dBm	-	-	-				
L_CCPCH33	-30.0 dBm	-	-	-				
L_CCPCH34	-30.0 dBm	-	-	-				
L_CCPCH35	-30.0 dBm	-	-	-				
L_CCPCH36	-30.0 dBm	-	-	-				
L_CCPCH37	-30.0 dBm	-	-	-				
L_CCPCH38	-30.0 dBm	-	-	-				
L_CCPCH39	-30.0 dBm	-	-	-				
L_CCPCH40	-30.0 dBm	-	-	-				
L_CCPCH41	-30.0 dBm	-	-	-				
L_CCPCH42	-30.0 dBm	-	-	-				
L_CCPCH43	-30.0 dBm	-	-	-				
L_CCPCH44	-30.0 dBm	-	-	-				
L_CCPCH45	-30.0 dBm	-	-	-				
L_CCPCH46	-30.0 dBm	-	-	-				
L_CCPCH47	-30.0 dBm	-	-	-				
L_CCPCH48	-30.0 dBm	-	-	-				
L_CCPCH49	-30.0 dBm	-	-	-				
L_CCPCH50	-30.0 dBm	-	-	-				
L_CCPCH51	-30.0 dBm	-	-	-				
L_CCPCH52	-30.0 dBm	-	-	-				
L_CCPCH53	-30.0 dBm	-	-	-				
L_CCPCH54	-30.0 dBm	-	-	-				
L_CCPCH55	-30.0 dBm	-	-	-				
L_CCPCH56	-30.0 dBm	-	-	-				
L_CCPCH57	-30.0 dBm	-	-	-				
L_CCPCH58	-30.0 dBm	-	-	-				
L_CCPCH59	-30.0 dBm	-	-	-				
L_CCPCH60	-30.0 dBm	-	-	-				
L_CCPCH61	-30.0 dBm	-	-	-				
L_CCPCH62	-30.0 dBm	-	-	-				
L_CCPCH63	-30.0 dBm	-	-	-				
L_CCPCH64	-30.0 dBm	-	-	-				
L_CCPCH65	-30.0 dBm	-	-	-				
L_CCPCH66	-30.0 dBm	-	-	-				
L_CCPCH67	-30.0 dBm	-	-	-				
L_CCPCH68	-30.0 dBm	-	-	-				
L_CCPCH69	-30.0 dBm	-	-	-				
L_CCPCH70	-30.0 dBm	-	-	-				
L_CCPCH71	-30.0 dBm	-	-	-				
L_CCPCH72	-30.0 dBm	-	-	-				
L_CCPCH73	-30.0 dBm	-	-	-				
L_CCPCH74	-30.0 dBm	-	-	-				
L_CCPCH75	-30.0 dBm	-	-	-				
L_CCPCH76	-30.0 dBm	-	-	-				
L_CCPCH77	-30.0 dBm	-	-	-				
L_CCPCH78	-30.0 dBm	-	-	-				
L_CCPCH79	-30.0 dBm	-	-	-				
L_CCPCH80	-30.0 dBm	-	-	-				
L_CCPCH81	-30.0 dBm	-	-	-				
L_CCPCH82	-30.0 dBm	-	-	-				
L_CCPCH83	-30.0 dBm	-	-	-				
L_CCPCH84	-30.0 dBm	-	-	-				
L_CCPCH85	-30.0 dBm	-	-	-				
L_CCPCH86	-30.0 dBm	-	-	-				
L_CCPCH87	-30.0 dBm	-	-	-				
L_CCPCH88	-30.0 dBm	-	-	-				
L_CCPCH89	-30.0 dBm	-	-	-				
L_CCPCH90	-30.0 dBm	-	-	-				
L_CCPCH91	-30.0 dBm	-	-	-				
L_CCPCH92	-30.0 dBm	-	-	-				
L_CCPCH93	-30.0 dBm	-	-	-				
L_CCPCH94	-30.0 dBm	-	-	-				
L_CCPCH95	-30.0 dBm	-	-	-				
L_CCPCH96	-30.0 dBm	-	-	-				
L_CCPCH97	-30.0 dBm	-	-	-				
L_CCPCH98	-30.0 dBm	-	-	-				
L_CCPCH99	-30.0 dBm	-	-	-				
L_CCPCH100	-30.0 dBm	-	-	-				

Power Monitor

Slow Clock Tests Using DBB

The MD8480C has I/O interfaces for both digital baseband (DBB) and analog baseband (ABB) where the MU848077C Baseband Interface Unit (BIU) can be installed. The BIU supports performance and function tests, including analog/digital IQ coding and decoding tests, plus baseband chip testing independent of the RF block performance. Moreover, the BIU supports configuration of a coding and decoding test environment with high reproducibility by slowing the clock rate.

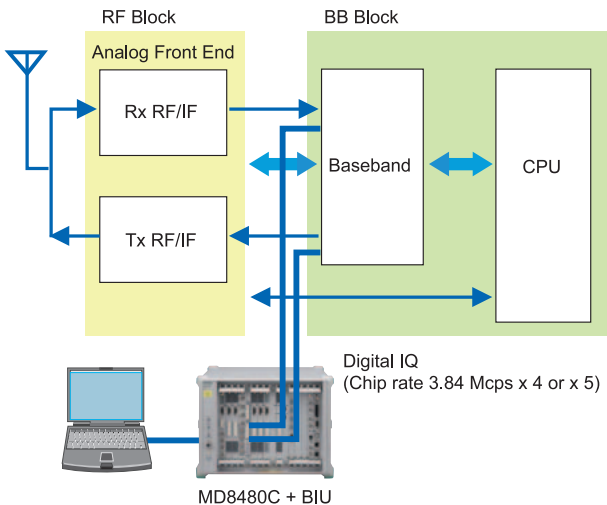

Counter		Current PHY/BI	Accumulate PHY/BI
Duration: 500 ms			
L1			
L2			
Name			
<input type="checkbox"/> HS-DSCH			
<input type="checkbox"/> MAC-hs PDU Tx Rate		13,648.430	13,644.700
<input type="checkbox"/> Tx Rate [kbit/s]		13,648.430	13,641.159
<input type="checkbox"/> Tx Throughput1 [kbit/s]		0.000	0.000
<input type="checkbox"/> Tx Throughput2 [kbit/s]		0.000	0.000
<input type="checkbox"/> MAC-hs PDU/PDU Size		250	63,750
<input type="checkbox"/> Tx MAC-hs PDU [PDU/s]		250	63,733
<input type="checkbox"/> Acknowledged Tx MAC-hs PDU [PDU/s]		27,952	7,125,959
<input type="checkbox"/> MAC-hs PDU average size [bits]		250	63,733
<input type="checkbox"/> HS-DPCCH ACK		0	17
<input type="checkbox"/> ACK		0	0
<input type="checkbox"/> NACK		0	0
<input type="checkbox"/> DTX		0	0
<input type="checkbox"/> HS-DPCCH CQI		30,000	30,000
<input type="checkbox"/> Average CQI		0	0
<input type="checkbox"/> CQI#0 [dB]		0	0
<input type="checkbox"/> CQI#1 [dB]		0	0
<input type="checkbox"/> CQI#2 [dB]		0	0
<input type="checkbox"/> CQI#3 [dB]		0	0
<input type="checkbox"/> CQI#4 [dB]		0	0
<input type="checkbox"/> CQI#5 [dB]		0	0
<input type="checkbox"/> CQI#6 [dB]		0	0
<input type="checkbox"/> CQI#7 [dB]		0	0
<input type="checkbox"/> CQI#8 [dB]		0	0
<input type="checkbox"/> CQI#9 [dB]		0	0
<input type="checkbox"/> CQI#10 [dB]		0	0
<input type="checkbox"/> CQI#11 [dB]		0	0
<input type="checkbox"/> CQI#12 [dB]		0	0
<input type="checkbox"/> CQI#13 [dB]		0	0
<input type="checkbox"/> CQI#14 [dB]		0	0
<input type="checkbox"/> CQI#15 [dB]		0	0
<input type="checkbox"/> CQI#16 [dB]		0	0
<input type="checkbox"/> CQI#17 [dB]		0	0
<input type="checkbox"/> CQI#18 [dB]		0	0
<input type="checkbox"/> CQI#19 [dB]		0	0
<input type="checkbox"/> CQI#20 [dB]		0	0
<input type="checkbox"/> CQI#21 [dB]		0	0
<input type="checkbox"/> CQI#22 [dB]		0	0
<input type="checkbox"/> CQI#23 [dB]		0	0
<input type="checkbox"/> CQI#24 [dB]		0	0
<input type="checkbox"/> CQI#25 [dB]		0	0
<input type="checkbox"/> CQI#26 [dB]		0	0
<input type="checkbox"/> CQI#27 [dB]		0	0
<input type="checkbox"/> CQI#28 [dB]		0	0
<input type="checkbox"/> CQI#29 [dB]		0	0
<input type="checkbox"/> CQI#30 [dB]		0	0
<input type="checkbox"/> CQI#31 [dB]		0	0
<input type="checkbox"/> CQI#32 [dB]		0	0
<input type="checkbox"/> CQI#33 [dB]		0	0
<input type="checkbox"/> CQI#34 [dB]		0	0
<input type="checkbox"/> CQI#35 [dB]		0	0
<input type="checkbox"/> CQI#36 [dB]		0	0
<input type="checkbox"/> CQI#37 [dB]		0	0
<input type="checkbox"/> CQI#38 [dB]		0	0
<input type="checkbox"/> CQI#39 [dB]		0	0
<input type="checkbox"/> CQI#40 [dB]		0	0
<input type="checkbox"/> CQI#41 [dB]		0	0
<input type="checkbox"/> CQI#42 [dB]		0	0
<input type="checkbox"/> CQI#43 [dB]		0	0
<input type="checkbox"/> CQI#44 [dB]		0	0
<input type="checkbox"/> CQI#45 [dB]		0	0
<input type="checkbox"/> CQI#46 [dB]		0	0
<input type="checkbox"/> CQI#47 [dB]		0	0
<input type="checkbox"/> CQI#48 [dB]		0	0
<input type="checkbox"/> CQI#49 [dB]		0	0
<input type="checkbox"/> CQI#50 [dB]		0	0

Measure (Counter) Screen

HSDPA Parameter Statistical Analysis

For Developing GSM/GPRS/EGPRS UE

Features

- Supports all GSM bands
- Supports GSM to GSM handover*1
- Supports EGPRS
- Supports DTM (Dual Transfer Mode)

*1: Requires two TDMA2 units (MU848060C)

Main Test Functions

- EGPRS Packet Data Communications Test
- DTM (CS ↔ CS + PS, PS ↔ CS + PS) Test
- GSM/W-CDMA Inter-RAT Handover Test
- EGPRS/HSPA Inter-RAT Handover Test
- GSM Intra-RAT Handover Test
- GSM DTM ↔ W-CDMA Multi Call Handover Test

Basic Functions (GSM)

- Protocol Sequence Test (Basic Connection)
- Voice Communications Test (Handset Loopback)
- GPRS/EGPRS Packet Communications Test
- System Handover Test (GERAN ↔ UTRAN)
- Frequency Hopping (Option)
- GSM/GPRS Ciphering (Option)
- DTM (Dual Transfer Mode, Option)
- SMS (Short Message Service)
- SMSCB (SMS Cell Broadcast)

Supported Data

- Enhanced Full-Rate Speech (EFS)
- Full-Rate Speech (FS, Loopback)
- Half-Rate Speech (HS, Loopback)
- Adaptive Multiple Rate Speech (AMR)
- AMR-WB (Option)
- Packet (GPRS/EGPRS, Option)
- GSM CSD (57.6 kbps max., Option)

Supports All GSM Bands

The MD8480C supports an additional RF unit (MD8480C-04) to support the 8PSK reception modulation method required by EGPRS. The added bandwidth between 350 MHz and 2700 MHz will also support anticipated future bands.

Supported GSM Bands:

GSM450, GSM480, GSM850, GSM900, DCS1800, PCS1900

Supports GSM to GSM Handover Test

Adding two TDMA2 (MU848060C) units*2 supports GSM to GSM handover tests.

Since one MD8480C unit can simulate handover between GSM and W-CDMA base stations or between GSM base stations, this greatly enhances the investment in the test environment.

*2: The MU848077C Baseband Interface Unit cannot be installed.

Supports EGPRS

More GSM service regions are using EGPRS services, which is an enhanced version of the GPRS packet, to offer faster packet data services. The MD8480C supports EGPRS packets by installing the TDMA2 (MU848060C) and EGPRS options (MU848060C-01) to perform data tests up to 230 kbps.

Main Specifications

- Supports 3GPP: Rel. 99 (June 2001)
- Supports MCS (Modulation & Coding Scheme): 1 to 9
- Supports MSC (Multislot Class): 1 to 12, 32 to 34
- ARQ Types: 1, 2
- Bit rate: 230 kbps max.

In addition, expanding development of global GSM and 3G services is increasing sales of dual-mode UE supporting HSPA.

The future will see increasing demand for handover tests between GERAN and UTRAN networks, but just a single MD8480C unit combining the EGPRS and HSPA functions will support EGPRS-HSPA Inter-RAT handover tests.

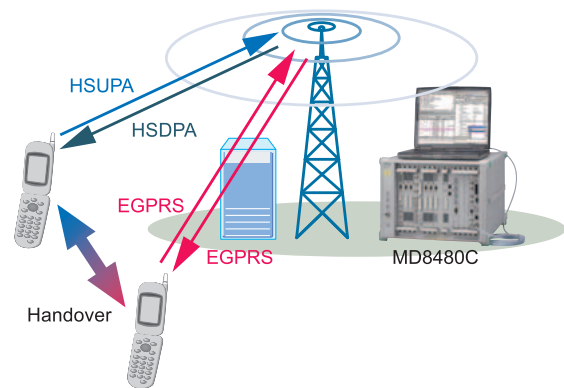

EGPRS-HSPA Handover Test

DTM (Dual Transfer Mode)

Adding the DTM option (MX848001C-30) supports simulation of the Dual Transfer Mode Function at actual Voice (CS) + Data (PS) connection. When the EGPRS (MU848060C-01) option is added to support both CS ↔ CS + PS and PS ↔ PS + CS, GSM DTM and EGPRS function testing is supported. Moreover, when the DTM option is used in combination with the W-CDMA Multi Call configuration, a single MD8480C can also handle W-CDMA Multi Call Handover testing.

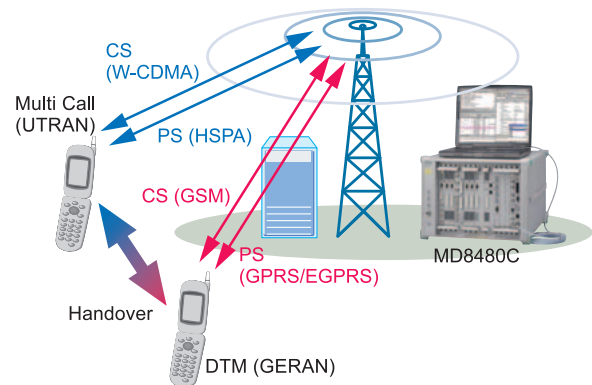

GERAN-UTRAN Handover Test

For Coding/Decoding and Baseband Tests

Coding/Decoding Test Setup 1 (RF, Harikiri)

W-CDMA mobile station coding and decoding functions can be tested using the setup shown in the diagram below. In the coding test, fixed and variable data (such as PN9) output from the W-CDMA mobile station coding unit is compared with the decoding results shown on the Trace screen. In addition, simultaneous BLER and BER tests are supported (BER tests require an external BER counter) and received signal timing errors can be displayed.

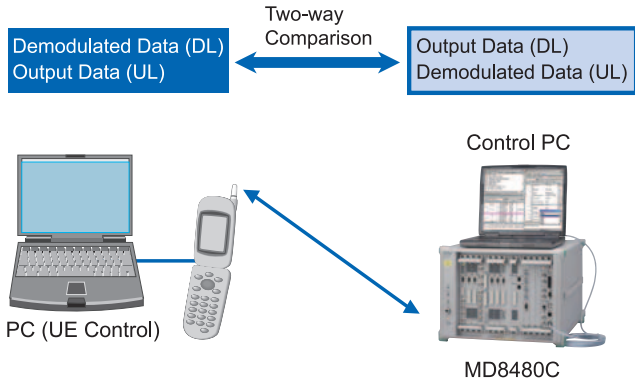

Coding/Decoding Test Setup 2 (RF, Demodulation)

The setup shown on the right can monitor the MD8480C downlink output constellation (QPSK/16QAM/64QAM) and power control condition, using the MS2691A Signal Analyzer to configure a fading simulator. This also enables visual checking of various mobile station operations in a dynamic environment, such as CQI notification to base station.

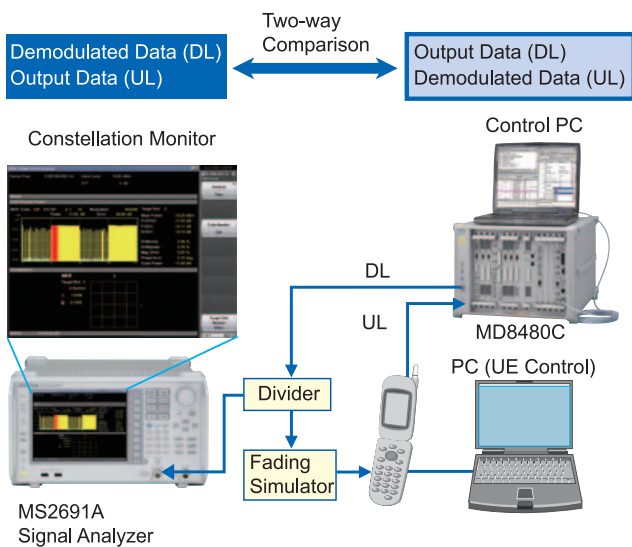

Coding/Decoding Test (Baseband)

The MU848077C Baseband Interface Unit (BIU – sold separately) with both DBB (digital baseband) and ABB (analog baseband) I/O functions can be installed in the MD8480C.

The BIU supports coding/decoding tests with good reproducibility. In addition, the AWGN signal source built into the MD8480C supports evaluation in a noisy environment, as well as coding/decoding tests under a fading environment by connecting an external digital fading simulator*1.

<Main BIU Functions>

- Analog IQ I/O
- Digital IQ I/O
- Select either internal or external clock synchronization for each I/O
- Select any frequency within range of 0.01 MHz to 19.2 MHz at external clock
- Select either 4 or 5 times chip rate for either internal or external clock
- Install two BIU units in one MD8480C*2
- Efficient MIMO tests

Item	I/O Level	Chip X5		Chip X4	
		Internal	External	Internal	External
Analog I/Q	-1.0 V to +1.0 V	√	√*3	√	√*3
Digital I/Q	3.3 V CMOS OUT, TTL IN	√	√	√	√
Fading	LVDS	√	√	√	√

*1: Requires MF6900A Fading Simulator

*2: The TDMA2 (MU848060C) modules cannot be installed. When two BIU modules are installed, the GSM test function using the TDMA2 is not supported.

*3: Only data as analog output. Supports only clock input at sync to external clock

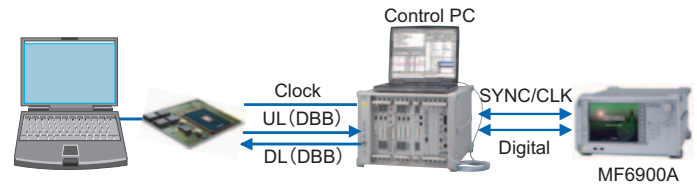

Coding/Decoding Test Setup 3 (Digital baseband)

Protocol Tests

Protocol Sequence Test (in C)

The protocol sequence of W-CDMA/GSM UE can be tested by connecting the equipment as shown in the following diagram to test broadcast information transmission, location registration, mobile station origination, disconnection from mobile station/network, handover. Test parameters and sequence can be defined freely to perform quasi-normal and interrupt testing. In addition, data transfer between the UE and MD8480C can be monitored simultaneously in real time. These functions support troubleshooting as well as efficient protocol sequence tests for chipsets and UE.

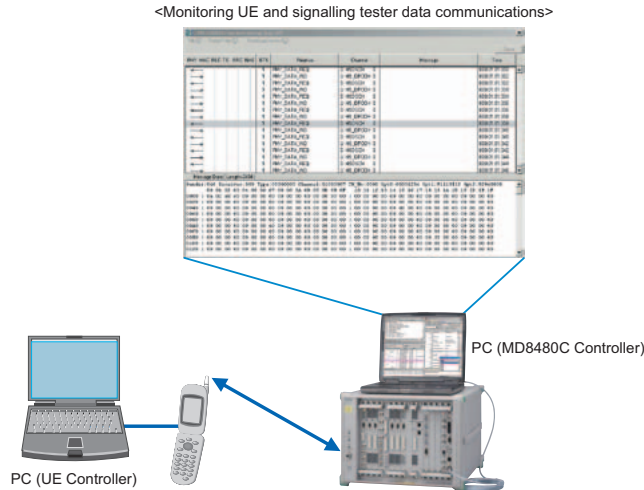

Protocol Sequence Test Example

Scenario Creation and Simulation Result Analysis (Message Coder)

The MD8480C has a built-in Message Coder tool for encoding/decoding important protocol messages at C scenario creation and analysis of simulation results. Message Coder is a software tool for creating and analyzing higher-layer messages exchanged between W-CDMA/GSM base stations and UE. It supports encoding/decoding of RRC, NAS (RR, CC, MM, GMM, SM), SMS, SS (Supplementary Service) protocol messages for efficient scenario creation, including layer-3 messages.

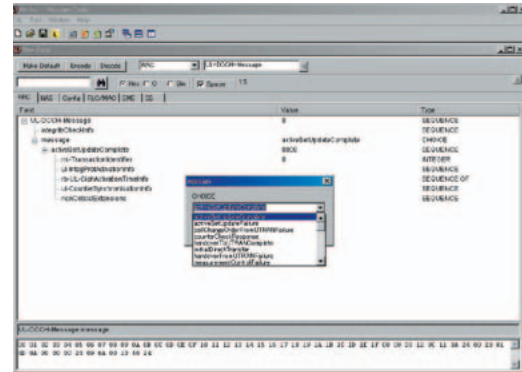

Message Coder Main Screen

Supported Messages

Category	Message	Reference Spec. *1
RRC	RRC Layer	3GPP TS 25.331
NAS	NAS Layer	3GPP TS 24.007, TS 24.008
Config	Layer 1, Layer 2 Control	—
RLC/MAC Control	RLC/MAC Control	3GPP TS 04.60
SS	Supplementary Service	3GPP TS 24.080
SMS	SMS (SM-RL/SM-TL)	3GPP TS 23.040
CBS	CBS	3GPP TS 23.041, TS 25.324
ULP	User-Plane Location Protocol	OMA-TS-ULP-V1_0-20070615-A
RRLP	Radio Resource LCS Protocol	3GPP TS 44.031
Layer 3 Messages *2		Reference Spec. *1
CC	Messages for Circuit-switched Call Control (35)	3GPP TS 24.008, 9.3
MM	Messages for Mobility Management (22)	3GPP TS 24.008, 9.2
GMM	GPRS Mobility Management Messages (23)	3GPP TS 24.008, 9.4
SM	GPRS Session Management Messages (16)	3GPP TS 24.008, 9.5
SMS	Messages for Short Message or Notification Transfer on CM (3)	3GPP TS 24.001, 7.2
RR	Messages for Radio Resource Management (82)	3GPP TS 04.18, 9.1
SS	Messages for Supplementary Services Control (3)	3GPP TS 24.080, 2.2

*1: Bundled RRC and NAS definition files are standardized by 3GPP in June 2001 (R99), March 2002 (R99), December 2002 (R99), December 2005 (Rel. 5), January 2006 (Rel. 6), March 2009 (Rel. 8), March 2011 (Rel. 8) and March 2012 (Rel. 9). RRC definition files standardized in September 2007 (Rel. 7), September 2008 (Rel. 7), June 2008 (Rel. 8), June 2009 (Rel. 8), December 2010 (Rel. 8) and March 2012 (Rel. 9) are also bundled.

*2: High-layer protocols in messages are not supported.

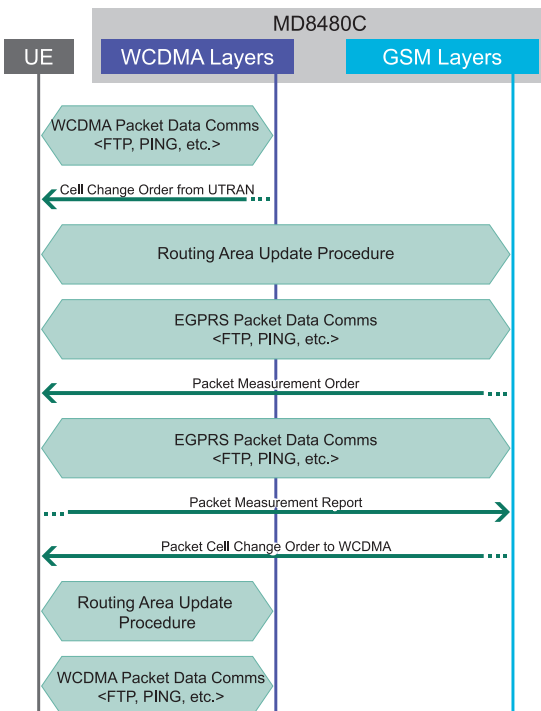

W-CDMA and EGPRS HO Protocol Sequence Test Example

Protocol Tests

Bundle Reference Sample Scenarios

The MX848000C Control Software bundle has over 450 sample scenarios (in C). Of course, there are scenarios for Harikiri testing using encoding/decoding tests, plus sample scenarios*1 based on actual connections with commercial W-CDMA UE, allowing protocol testing to be started almost immediately.

Furthermore, for GSM systems, GSM-GSM Intra-RAT handover and GSM-WCDMA Inter-RAT handover sample scenarios are also bundled as standard. Since any test sequence and parameters can be created and set based on these sample scenarios, protocol tests are easily performed for handover between a huge range of systems*2.

*1: The default setting uses the W-CDMA/GSM Test USIM (P0027/P0035B). Functions are not guaranteed for all commercial UE.

*2: Ensure that the required hardware and software are setup.

Main Sample Scenario List

W-CDMA

Type	Function	Remarks
Registration	Idle, Attach (CS, PS, Combined)	
Voice (AMR-NB, AMR-WB)	Originate, Terminate (UE/Network)	Handset, Loopback
Packet (PPP)	Originate, Release (UE/Network)	Internal Server, External Server
Packet (IP)	Originate, Rate Change, Release (UE/Network)	External Server
Packet (HSPA)	Originate, Release (HSDPA, HSUPA, 64QAM)	External Server
Video call	Originate, Release (UE/Network)	TE, Loopback

Inter-RAT

Type	Function	Remarks
Intra-RAT Handover, Cell Reselection, Cell Change	Intra-cell Handover, Inter-cell Handover (Sync/Async), GSM/GPRS Cell Reselection, GPRS Packet Cell Change Order Inter-SGSN	
Inter-RAT Handover	Voice Handover (W to G to W), GPRS Packet cell change (G to W, W to G) Multi-call Handover (G to W, W to G)	

GSM

Type	Function	Remarks
Registration		
Voice (EFS, AMR)	Originate, Terminate (UE/Network)	Handset, Loopback
Voice (FS, HS, AMR-WB)	Originate, Terminate (UE/Network)	Handset, Loopback
Voice + SMS	Voice (EFS) + SMS Receive	SACCH
SMS	SMS Receive	SDCCH, SACCH
SMS Cell Broadcast	SMSCB Receive	
Packet (GPRS)	Originate, Terminate (UE/Network)	
Packet (EGPRS)	Originate, Terminate (UE/Network)	
CSD/HSCSD	Originate, Terminate (UE/Network)	
Frequency Hopping	Originate, Terminate (Voice Call)	
Multiple PDP Context	IP Packet Originate (UE), Terminate (Network)	Primary + Primary, Primary + Secondary
DTM (Dual Transfer Mode)	Voice (EFS) + Packet (GPRS/EGPRS)	CCCH/BCCH, PCCCH/PBCCH Comb11

Application Tests

Application Tests (Voice)

The MD8480C supports a full range of application tests.

• AMR Voice Test

The handset (standard accessory) is connected to the MD8480C and an AMR Voice Test can be performed between the UE and signalling tester.

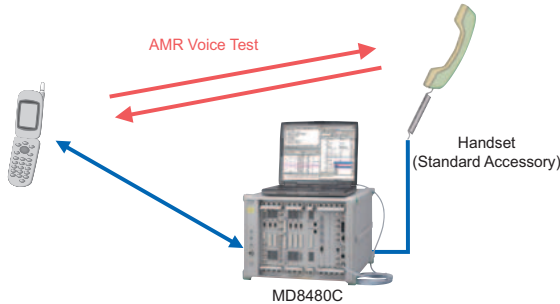

AMR Voice Test Example

• EFR/FR/HR (GSM) Voice Test

The MX848062C Multimedia Interface Software (MIS) option is installed in an external PC and when a handset (PC accessory) is connected to the PC, EFR (Enhanced Half Rate Speech), FR (Full Rate Speech) and HR (Half Rate Speech) voice tests can be performed between the GSM UE and PC handset.

• AMR-WB (W-CDMA/GSM) Voice Test

When the MX848062C-001 AMR-WB option is added to the MX848062C MIS installed in the external PC and a handset (PC accessory) is connected to the PC, voice tests between the UE and PC handset can be performed using the AMR-Wideband codec.

Supported Voice Codecs

Supported Codec	MU848056A Voice Codec (Standard Unit)	MX848062C MIS (option, external PC)	MX848062C-001 AMR-WB (option, external PC)
AMR-NB (W-CDMA, GSM)	√	√	
GSM - EFR (GSM)	√	√	
GSM - FR (GSM)	√ (Loopback only)	√	
GSM - HR (GSM)	√ (Loopback only)	√	
AMR-WB (W-CDMA, GSM)			√

• AMR + Packet Test

Inserting a switching hub enables multicall testing with simultaneous AMR Voice tests using the MIS and packet data communications tests with a connected FTP/application server.

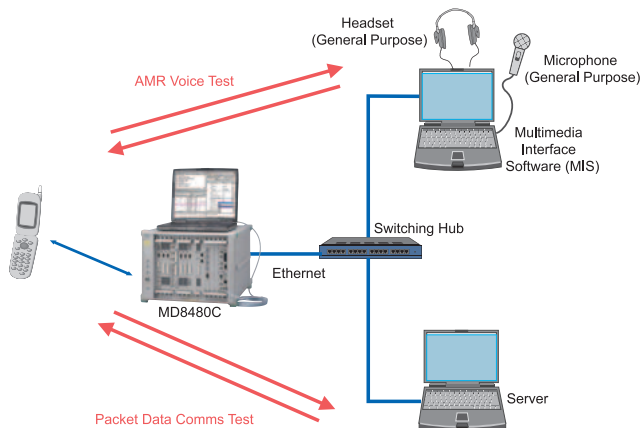

AMR + Packet Test Setup Example

Application Tests (Packet/AV/UDI)

• IP Packet Test

Connect a PC (using 10/100BASE-T) to the MD8480C and perform IP protocol tests.

• PPP (Built-in Server) Packet Test

This packet data test uses the MD8480C built-in PPP protocol stack. Since the connection with the PC is over Ethernet, data communications are performed at high speed (DL: 28 Mbps/UL: 11 Mbps when HSDPA/HSUPA option installed). A unique feature is the PPP termination in the MD8480C.

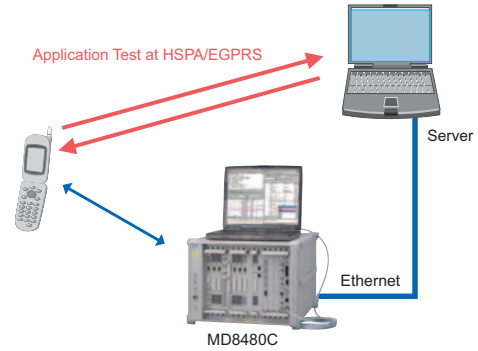

IP Packet Test

• PPP (Serial Connection) Packet Test

Connect a PC (using serial connection) to the MD8480C and data communications can be performed using PPP (requires MU848055C ISDN/CSD).

• User Data Test

Any data can be inserted into the Tx DTCH and the demodulated DTCH data can be captured externally, which is useful for error-rate measurements.

• Videophone (AV) Test

Videophone tests can be performed by using the Loopback mode to loop-back the video and voice to the base station and confirm mobile operation. Moreover, connecting the ISDN Videophone terminal to the MD8480C using an ISDN I/F supports End-to-End videophone tests between the mobile and videophone terminal.

• UDI Communications Test

Using an ISDN I/F and connecting a terminal adapter (TA) supporting UDI allows UDI communications tests.

• MS-to-MS Test

When two MD8480C units are connected by 100BASE-T/BASE-TX, MS-to-MS tests of two mobile terminals can be performed.

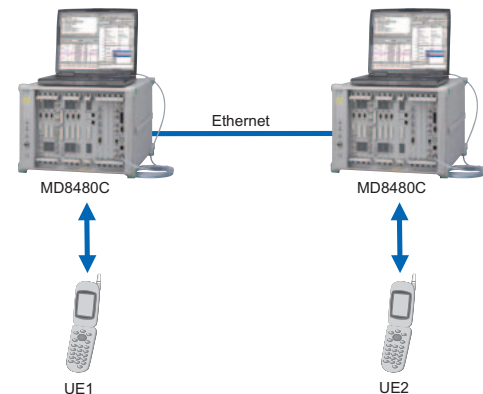

MS-to-MS Test

For 3GPP Protocol Conformance Tests



The MD8480C W-CDMA Signalling Tester is used with the MX785201A PTS Core Software to configure a measurement system for Layer 3 and Layer 2 signalling protocols defined by the Third Generation Partnership Project (3GPP). The PTS is designed for testing 3G W-CDMA UE signalling protocols.

Protocol Testing

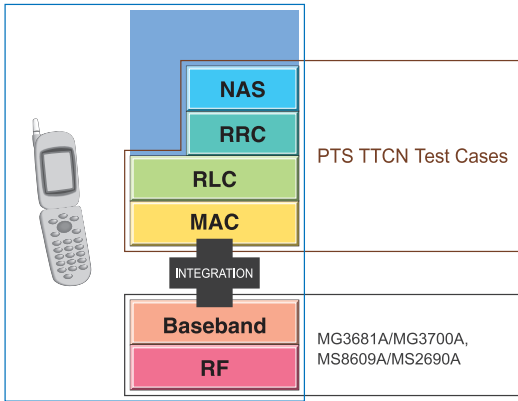

* See the MX785201A data sheet for more details.

Integration and Conformance

Software/Hardware Development and Integration

- Protocol stack development
- UE Integration testing - debugging hardware and software
- Regression testing of new builds

Conformance Testing

- Pre-conformance testing
- GCF/PTCRB Certification

GCF/PTCRB Approved Test Platform

The PTS and MD8480C capability will be extended in-line with the 3GPP specifications.

For GCF/PTCRB terminal certification, PTS delivered with GCF/PTCRB Protocol Conformance Test Toolkits option.

PTS + MD8480C

MX785220A
GCF/PTCRB Protocol Conformance Test Toolkit

Certification Environment
MX785220A-xx
GCF Work Item Test Cases

MX785220A-xx
Frequency Band Options

MX785220A-20
Annual Update and Maintenance Contract

- * See the MX785220A data sheet for more details.
- * Contact Anritsu sales for supported Work Item status.

PTS Libraries

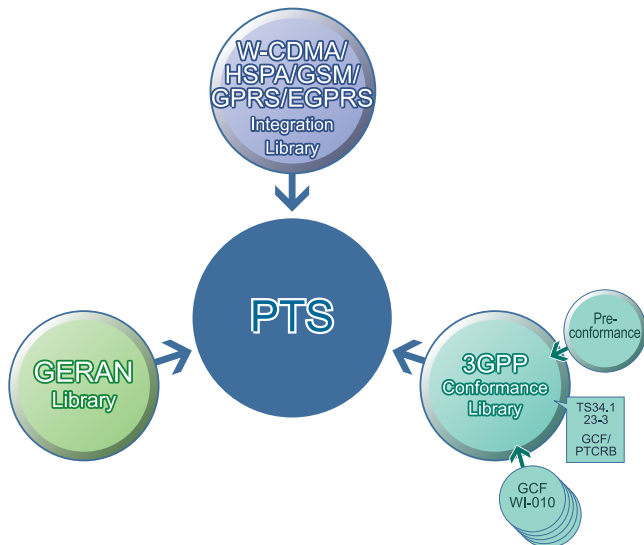

- Frequency band options and Library options can be purchased separately.
- For details of Band options and Libraries, see the MX785201A and MX785220A data sheet.

Protocol Analyzer

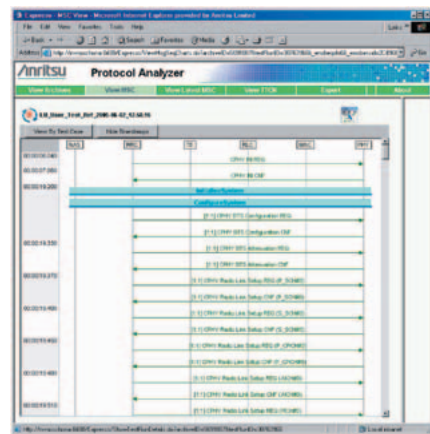

The PTS Core Software includes the Protocol Analyzer which displays comprehensive test results and logs using a web browser.

For Interoperability Test (IOT)

Interoperability

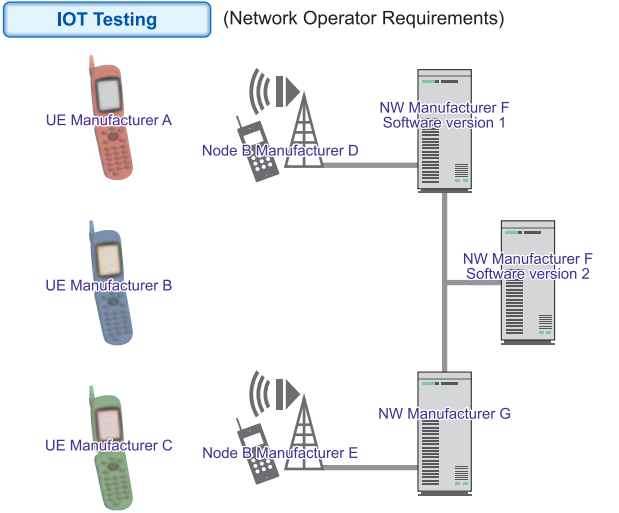

- Test correct functioning of different manufacturers' equipment in real network.
- Ensure terminals stay on their (or preferred) networks.
- Perform initial evaluation of products in 'real world' controlled environments.
- Test future network upgrades in laboratory.

MX786201A Rapid Test Designer (RTD)

The MX786201A RTD is a unique tool that significantly speeds up testing of W-CDMA/HSPA/GSM/GPRS/EGPRS.

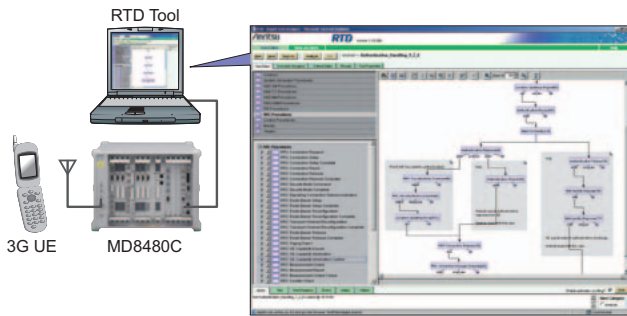

RTD Libraries

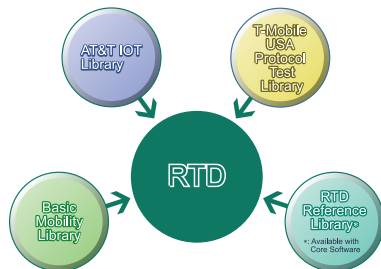

- Library options can be purchased separately.
- For details of libraries and specifications, see the RTD (MX786201A) data sheet.
- For details of T-Mobile USA Protocol Test Library, please contact local Anritsu sales team.

Cell Selection and Re-selection

There is always a compromise between battery life and continuous activities that the UE performs to ensure the correct network cell is used. Setting up controlled network simulations in the laboratory is the best way to check that UE algorithms perform correctly.

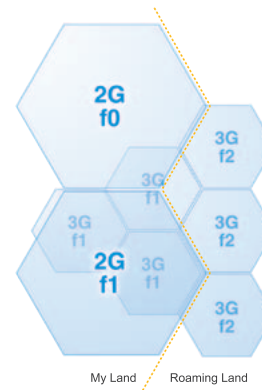

Simulation of Foreign Networks

Roaming between networks with different configurations/parameters and even different ways of implementing procedures creates unpredictable outcomes. Today, the cost of sending engineering teams to perform weeks of network testing can be a significant proportion of a proving budget. Combining the RTD with MD8480C handles roaming between different networks in the real world.

Field Trials vs. System Simulators

Live network testing will always be required, but system simulation in a laboratory is now a viable alternative using the RTD and MD8480C.

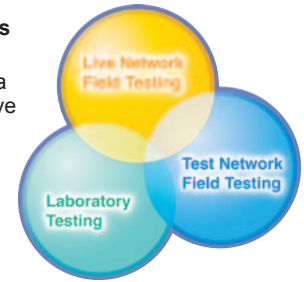

Using RTD and MD8480C for Wide Variety of Tasks

- Operator Acceptance Testing
- Interoperability Testing
- Application Testing
- Regression Testing
- Integration Testing
- Generating Variants
- Pre-conformance Testing
- Prototyping Tests
- Hardware and Software Integration
- Software Development

RTD Tools and MD8480C

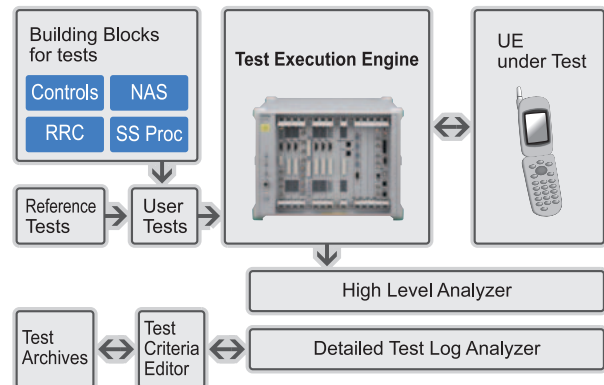

* See the MX786201A data sheet for more details.

Additional Options (Hardware)

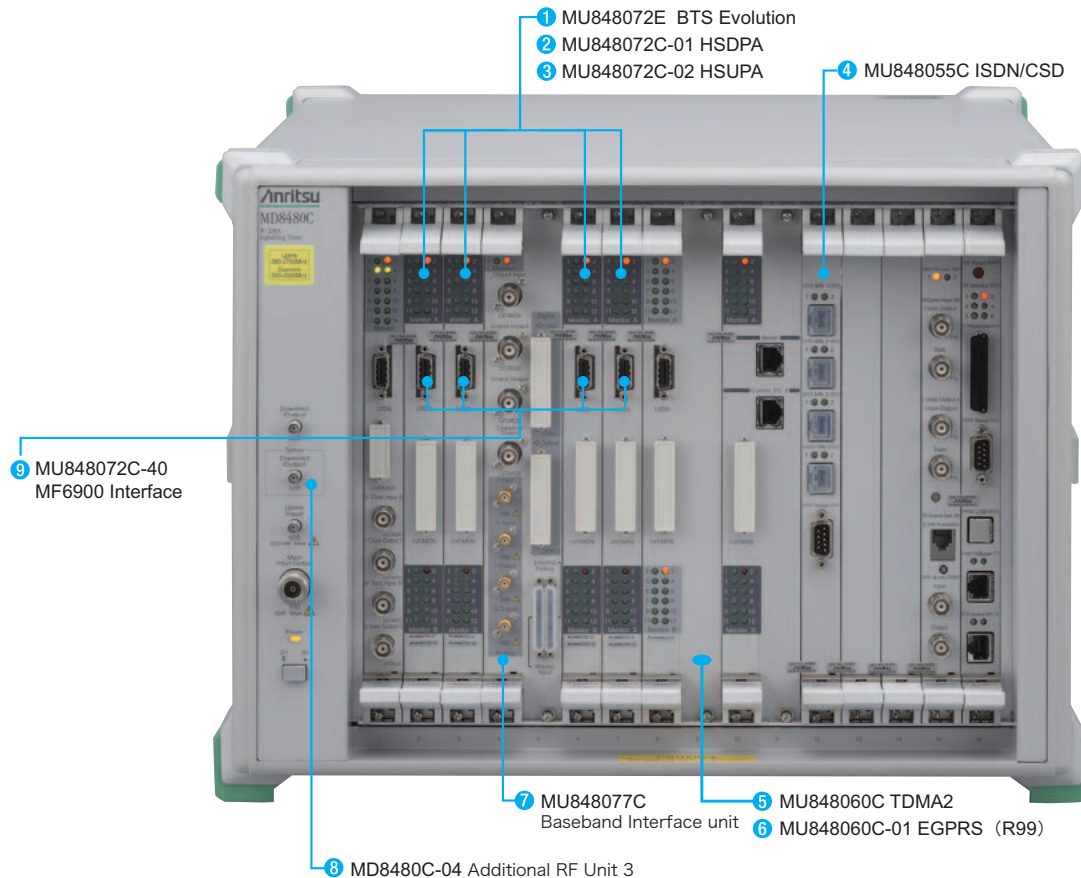

1 W-CDMA Base Station [MU848072E BTS Evolution]*1

The standard MD8480C configuration has one BTS unit for a single W-CDMA base station functionality. Adding this option in a single MD8480C supports for up to four W-CDMA base stations.

*1: HSPA Evolution Support type.

2 HSDPA Base Station [MU848072C-01 HSDPA]

This option adds the HSDPA functions for up to four base stations to the W-CDMA BTS Unit. Requires adding this option to each BTS Evolution unit.

3 HSUPA Base Station [MU848072C-02 HSUPA]

This option adds the HSUPA functions for up to four base stations to the W-CDMA BTS Unit. Requires adding this option to each BTS Evolution unit.

4 ISDN/CSD Unit [MU848055C ISDN/CSD]

This unit is required when adding software supporting CSD (Circuit Switched Data). It also adds an ISDN interface for performing UDI communications and videophone tests at data rates up to a maximum of 2B (64 kbps). PPP packet testing can also be performed using the RS-232C I/F built into this option.

5 GSM/GPRS Base Station [MU848060C TDMA2]

This option installs the GSM/GPRS function to support GSM/GPRS registration, mobile origination and termination, network origination and termination, and handover. And handover tests between W-CDMA (HSPA) and GSM/GPRS units are supported when used in combination with the MD8480C-04 Additional RF Unit 3 and the MX848001A-02 Compressed Mode described below. In addition, up to two units can be installed in one MD8480C, supporting the GSM transmit and receive function for each of two base stations.*2

*2: When two TDMA2 (MU848060C) units are installed, the Baseband Interface Unit (MU848077C) cannot be installed.

6 EGPRS Base Station [MU848060C-01 EGPRS (R99)]

This option installs the EGPRS base station function in the MU848060C TDMA2 option. Using the EGPRS method (3GPP Release 99) supports packet testing at up to 230 kbps.

7 Baseband Interface [MU848077C Baseband Interface Unit]

This option adds I/O interfaces for DBB (digital baseband) and ABB (analog baseband) to the MD8480C. It support baseband evaluation of W-CDMA/HSPA chipsets and UE reference design boards.

8 Additional RF Interface [MD8480C-04 Additional RF Unit 3]

This option adds support for two different frequencies (transmit and receive) and is required when adding the GSM/GPRS base station option (MU848060C). When it is used with the above-described base station options, it supports hard handover testing (HHO) between different frequencies. The continuously covered transmit and receive frequency range is 350 MHz to 2700 MHz.

9 Fading Simulator Connection Function [MU848072C-40 MF6900 Interface] *3

The LVDS interface connects the MF6900A Fading Simulator to support high-reproducibility fading simulation.

*3: Installed in MU848072E BTS Evolution as standard function. This option is required for the conventional MU848072C1 BTS unit.

Additional Options (Software)

* See the table on page 18 and 19 for required hardware and software configurations.

W-CDMA/HSPA Related

• Diversity Function

MX848001A-01 W-CDMA Signalling Tester Tx Diversity

This option supports the Tx diversity functions, including TSTD, STTD, Closed Loop Mode 1 and Closed Loop Mode 2.

• HSDPA Diversity Function

MX848001C-11 HSDPA Tx Diversity

This option supports the Tx/Rx diversity function for HSDPA/HSUPA.

• Compressed Mode Function

MX848001A-02

W-CDMA Signalling Tester Compressed Mode

This option supports the compressed mode function used mainly for hard handover (HHO) tests. SF/2, Puncturing, and Higher Layer Scheduling are also supported by this option.

• W-CDMA CSD Function

MX848001A-06 W-CDMA Signalling Tester W-CDMA CSD

This option supports W-CDMA CSD (Circuit Switched Data) and adds CSD-dedicated layers (L2RCOP, RLP) providing 14.4/28.8/57.6 kbps asynchronous and non-transparent mode test functions.

• 3GPP Release 7 Function

MX848001C-12 HSPA Evolution (Release 7)

This option supports the HSPA Evolution functions, including CPC (Continuous Packet Connectivity), Enhanced Cell FACH, L2 improvement, CS Voice over HSPA.

• HSDPA 64QAM, HSUPA 16QAM Function

MX848001E-13 Higher Order Modulation (Release 7)

This option supports Higher Order Modulation defined by 3GPP Release 7. It supports downlink (DL) 64QAM modulation and Uplink (UL) 16QAM demodulation scheme. It also achieves maximum data transfer speed 21 Mbps (DL) and 11 Mbps (UL).

• 2 × 2 MIMO Function

MX848001E-14 2 × 2 MIMO (Release 7)

This option supports 2 × 2 MIMO defined by 3GPP Release 7. By adding this option, it achieves maximum data transfer speed 28 Mbps (DL).

• 3GPP Release 8 Function

MX848001E-15 HSPA Evolution for uplink (Release 8)

This option supports the Improved L2 for UL, and Enhanced UL for Cell FACH State defined by 3GPP Release 8.

• Dual Cell HSDPA Function

MX848001E-16 DC-HSDPA (Release 8)

This option supports the DC-HSDPA function (3GPP Release 8). It also supports the maximum data transfer speed of 42 Mbps (DL).

• 64QAM and MIMO Function

MX848001E-17 64QAM and MIMO for HSDPA (Release 8)

This option supports the 64QAM and MIMO function defined by 3GPP Release 8. It also supports the maximum data transfer speed of 42 Mbps (DL).

• DB-DC-HSDPA Function

MX848001E-18 DB-DC-HSDPA (Release 9)

This option supports the DB-DC-HSDPA function (3GPP Release 9). It also supports a maximum data download speed of 42 Mbps. Unlike the DC-HSDPA function, which is for use in the same frequency band, this function supports transmission of each carrier frequency in a different frequency band.

• W-CDMA Ciphering

MX848041E Firmware for Ciphering

This option*1 adds support for ciphering functions to KASUMI and SNOW 3G (3GPP standards integrity ciphering algorithm).

• HSPA Ciphering

MX848041E-10 HSDPA Ciphering

This option*1 adds supports for ciphering functions to KASUMI and SNOW 3G (3GPP standards integrity ciphering algorithm).

*1: The integrity function is also supported even without this option.

GSM/GPRS/EGPRS Related

• GSM CSD Function

MX848001A-04 W-CDMA Signalling Tester GSM CSD

This option supports the GSM CSD (Circuit Switched Data) function and PPP packets at data rates from 9.6 to 57.6 kbps (HSCSD). It also supports asynchronous mode data transmission in the non-transparent mode.

• GSM Frequency Hopping Function

MX848001A-05

W-CDMA Signalling Tester GSM Frequency Hopping

This option supports the GSM frequency hopping function, permitting frequency hopping in GSM communications channels at a frame sync of 4.62 ms.

• DTM Function

MX848001C-30 DTM (R99)

This option adds the Dual Transfer Mode (DTM) function which is able to simulate Voice (CS) + Data (PS) communication based on the 3GPP Release 99. In addition, this option is able to Handover test between DTM and Multi Call connection if used with the W-CDMA Multi Call configuration on the single unit.

• GSM/GPRS Ciphering

MX848045C GSM/GPRS 2 Ciphering

This option adds the GSM/GPRS ciphering function to support the GSM A5/1, A5/2 and A5/3 ciphering algorithm as well as the GPRS GEA1, GEA2 and GEA3 ciphering algorithm.

Shared

• Router Connection Function

MX848001A-03

W-CDMA Signalling Tester Router Connection

This option provides support for data communications with PCs on a different subnet mask (segment) and can be used for both W-CDMA and GPRS data. RoHC (Robust Header Compression) is also supported. In addition, it can also be used for testing both IP and PPP packets.

• Message Encoder/Decoder Function

MX848001A-07 Message Encoder/Decoder

The provided protocol message encoder/decoder library supporting RRC, NAS (RR, CC, MM, GMM, SM), SMS and SS (Supplementary Service) makes it easy to change or extract message information elements in test scenarios. This feature supports scenario conditional branch processing and received message analysis.

• WNS Function

MX848060E WNS Evolution

MX848060E-001 3GPP Release 7

MX848060E-002 3GPP Release 8

To install this software in control PC, the following simulation can be performed without creating scenario. - Voice Call Test, Packet Communication Test, Video Call Test, SMS/MMS Test, Out of service Test, Packet Preservation Test, Emergency Call Test, Cell Barred Test, ICE_T Test, and Battery Life Test.

• Voice Codec Function

MX848062C Multimedia Interface Software*2

The Multimedia Interface Software (MIS) is application software providing a voice codec function. When it is installed in an external PC connected to the MD8480C by Ethernet cable, End-to-End Voice communications can be tested between a microphone and speaker connected to the external PC and a mobile terminal. (See the table on page 9 for the supported voice codecs).

• AMR-WB Function

MX848062C-001 AMR-WB*2

This option adds the ANSI-C code for the Adaptive Multi Rate - Wideband (AMR-WB) speech codec (Release 6) specified in 3GPP TS 26.173 to the MIS.

*2: A PC is required to use the MX848062C MIS.

The specifications required for stable operation are listed below.

<Recommended specifications>

OS: Windows 2000/XP

CPU: Pentium 4 (1.6 GHz) or better

Memory: 512 MB min.

Others: Microphone input connector, Headphone output connector, One free LAN port

Other Options

Software Maintenance Contracts

<Provide Service>

- 3GPP Software upgrades and revisions
- Technical support for solving user problems

• W-CDMA/GSM 1-year Support Service [MD8480C-SS120, MD8480C-SS121]*1

This optional 1-year contract provides the support services for W-CDMA/GSM functions. The MD8480C-SS120 software service contract is for W-CDMA/GSM related functions of the MD8480C; the MD8480C-SS121 contract is for ciphering (MX848041E/MX848045C) related functions.

• HSDPA 1-year Support Service [MD8480C-SS122, MD8480C-SS123]*1

This optional 1-year contract provides the support services for HSDPA functions. The MD8480C-SS122 software service contract is for HSDPA-related functions of the MD8480C; the MD8480C-SS123 contract is for HSDPA ciphering (MX848041E-10) related functions.

• HSUPA 1-year Support Service [MD8480C-SS124, MD8480C-SS125]*1

This optional 1-year contract provides the support services for HSUPA functions. The MD8480C-SS124 software service contract is for HSUPA-related functions of the MD8480C; the MD8480C-SS125 contract is for HSDPA ciphering (MX848041E-10) related functions.

*1: For contract details, see the appended materials.

• MD8480C 1-year Package Support Service [MD8480C-SS150, MD8480C-151]*2

This optional 1-year contract provides the support services for all system functions of the MD8480C. The MD8480C-SS150 software service contract is for all MD8480C systems software (W-CDMA/GSM/HSPA functions); the MD8480C-SS151 contract is for MD8480C ciphering (MX848041E/MX848045C) related functions.

• MD8480C 2-year Package Support Service [MD8480C-SS250, MD8480C-251]*2

This optional 2-year contract provides the support services for all system functions of the MD8480C. The MD8480C-SS250 software service contract is for all MD8480C systems software (W-CDMA/GSM/HSPA functions); the MD8480C-SS251 contract is for MD8480C ciphering (MX848041E/MX848045C) related functions.

*2: All options for MD8480C-SS120/SS121/SS122/SS123/SS124/SS125. This option is valid for all W-CDMA/HSPA functions of the MD8480C. See the appended materials for the contract details.

Hardware Maintenance

• 2-year Extended Warranty Service [MD8480C-ES210]*3

This service extends the MD8480C standard 1-year warranty to 2 years.

• 3-year Extended Warranty Service [MD8480C-ES310]*3

This service extends the MD8480C standard 1-year warranty to 3 years.

• 5-year Extended Warranty Service [MD8480C-ES510]*3

This service extends the MD8480C standard 1-year warranty to 5 years.

*3: Consumables not included

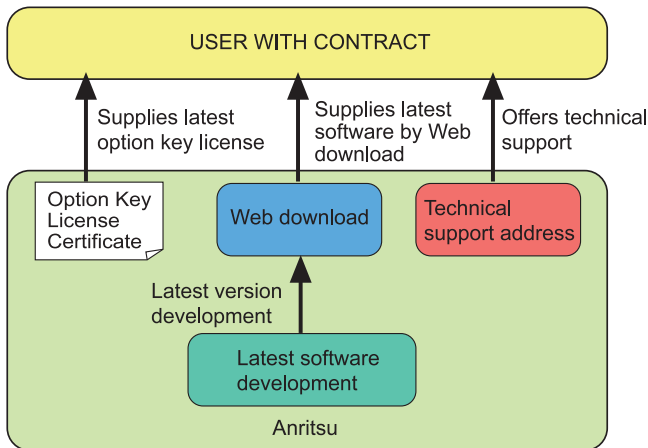

MD8480C Support System

Functions

Decoding Test Channels

Logical	Transport	Physical	Symbol Rate
BCCH	BCH	P_CCPCH+P_SCH+S_SCH	15 ksps
-	-	P-CPICH	
		S-CPICH	
		AICH	
	PICH		
PCCH	PCH		15 ksps to 480 ksps
CCCH/DCCH/DTCH	FACH	S-CCPCH	
MCCH/MSCH/MTCH			
DCCH + DTCH	DCH	DPDCH	7.5 ksps to 960 ksps
		DPCCH	
	HS-DSCH*1	HS-PDSCH*1	240 ksps × 15 code
		HS-SCCH	30 ksps × 4 code
-	-	E-HICH*2	30 ksps
		E-AGCH*2	15 ksps
		E-RGCH*2	30 ksps
-	-	F-DPCH	15 ksps

Coding Test Channels

Logical	Transport	Physical	Symbol Rate
CCCH/DCCH/DTCH	RACH	PRACH	15 ksps to 120 ksps
DCCH/DTCH	DCH	DPDCH	15 ksps to 960 ksps
		DPCCH	15 ksps
	E-DCH*2	E-DPDCH*2	15 ksps to 960 ksps × 4 code
		E-DPCCH*2	15 ksps
-	-	HS-DPCCH*1	15 ksps

*1: MU848072C-01 HSDPA is required

*2: MU848072C-02 HSUPA is required

Supported Services

Service		Data Rate	Physical Channel Downlink (1 symbol = 2 bits)	Physical Channel Uplink (1 symbol = 1 bit)
Protocol	Standalone DCCH	-	1xDPCH (15 ksps)	1xDPDCH (15 ksps)
	Voice (AMR)	12.2 kbps (VAD Opt. 01)	1xDPCH (30 ksps)	1xDPDCH (60 ksps)
	ISDN 1B	64 kbps	1xDPCH (120 ksps)	1xDPDCH (240 ksps)
Packet		32 kbps	1xDPCH (60 ksps)	1xDPDCH (120 ksps)
		64 kbps	1xDPCH (120 ksps)	1xDPDCH (240 ksps)
		128 kbps	1xDPCH (240 ksps)	1xDPDCH (480 ksps)
		384 kbps	1xDPCH (480 ksps)	1xDPDCH (960 ksps)
Audio and visual		32 kbps	1xDPCH (60 ksps)	1xDPDCH (120 ksps)
		64 kbps	1xDPCH (120 ksps)	1xDPDCH (240 ksps)
Reference measurement channel		DCCH	1xDPCH (15 ksps)	1xDPDCH (15 ksps)
		12.2 kbps	1xDPCH (30 ksps)	1xDPDCH (60 ksps)
		64 kbps	1xDPCH (120 ksps)	1xDPDCH (240 ksps)
		144 kbps	1xDPCH (240 ksps)	1xDPDCH (480 ksps)
		384 kbps	1xDPCH (480 ksps)	1xDPDCH (960 ksps)
		BTFD	1xDPCH (30 ksps)	1xDPDCH (60 ksps)
Multi call	Voice + Packet	12.2 kbps + 32 kbps	1xDPCH (15 ksps)	1xDPDCH (240 ksps)
		12.2 kbps + 64 kbps		
		12.2 kbps + 384 kbps		
	Voice + ISDN 1B	12.2 kbps + 64 kbps		1xDPDCH (240 ksps)

Specifications

MD8480C W-CDMA Signalling Tester

Electrical characteristics	Frequency range	Tx: 300 MHz to 3000 MHz Rx: 350 MHz to 2700 MHz*1
	Maximum input level (total level)	+40 dBm (Main connector), +20 dBm (Uplink connector)
	RF Input/Output connector	Main: N type, Impedance: 50Ω, VSWR: ≤1.3 Downlink 1: SMA type, Impedance: 50Ω, VSWR: ≤2.0 Downlink 2*2: SMA type, Impedance: 50Ω, VSWR: ≤2.0 Uplink: SMA type, Impedance: 50Ω, VSWR: ≤2.0
	Reference oscillator	Frequency: 10 MHz Startup characteristics: $\leq \pm 5 \times 10^{-8}$ (10 minutes after power-on, referenced to 24 hours after power-on) Aging rate: $\leq \pm 2 \times 10^{-8}$ /day, $\leq \pm 1 \times 10^{-7}$ /year (referenced to 24 hours after power-on) Temperature: $\leq \pm 5 \times 10^{-8}$ (0° to 40°C, referenced to 25°C) External reference input: BNC type, 10 MHz, 2 to 5 Vp-p Reference output: BNC connector, 10 MHz, TTL level
Transmitter	Frequency resolution	100 kHz
	Maximum Tx channels	30 ch (120 ch max. with option)
	Maximum Tx power	Main: -25 dBm/ch Downlink 1: -10 dBm/ch Downlink 2: -10 dBm/ch
	Tx Power setting range	Setting range: 0 to -120 dB from Tx power (by ATT) Resolution: 0.1 dB steps
	Level accuracy	±1.5 dB ≥ -113 dBm (18° to 28°C with calibrated CW)
	Modulation	QPSK, 16QAM (with MU848072C-01), 64QAM (with MX848001E-13)
	Chip rate	3.84 MHz
	Modulation band limit	Root Nyquist roll off ($\alpha = 0.22$)
	EVM	$\leq 7\%$ rms (1 ch)
Receiver	Frequency resolution	100 kHz
	Input level range	Main: -30 to +40 dBm Uplink: -50 to +20 dBm
	Modulation	BPSK, 4PAM (with MX848001E-13)
Others	Ambient temperature (operating)	0° to +40°C
	Ambient temperature (storage)	-40° to +70°C
	Power supply	100 V(ac) to 120 V(ac)/200 V(ac) to 240 V(ac), 50 Hz to 60 Hz, ≤650 VA
	Dimensions and mass	Dimensions: 426 (W) × 310 (H) × 500 (D) mm Mass: ≤35 kg
	EMC	EN61326-1 EN61000-3-2
	LVD	EN61010-1

*1: With yellow "Uplink 350 MHz to 2700 MHz" label attached to MD8480C front panel.

Units with no label are 350 MHz to 550 MHz, 700 MHz to 1100 MHz and 1400 MHz to 2200 MHz.

*2: With MD8480C-04 Additional RF unit 3. MD8480C-04 electrical and transmission characteristics same as above.

■ GSM Specifications: MU848060C TDMA2

Transmitter (GSM)	Frequency resolution	100 kHz
	Maximum Tx RF channel	2 ch*1
	Maximum output power	Main: -15 dBm Downlink 1: 0 dBm*1, *2 Downlink 2: 0 dBm
	Tx power setting range	Setting range: 0 to -120 dB from average Tx power (by ATT) Resolution: 0.1 dB steps
	Level accuracy	≤1.5 dB ≥-113 dBm (18° to 28°C with calibrated CW)
	Modulation	GMSK, 8PSK (with MU848060C-01)
	Symbol rate	270.833 kHz
	Phase error (GMSK)	≤5.0°rms
Receiver (GSM)	EVM (8PSK)	≤7%rms
	Frequency resolution	100 kHz
	Input level range	Main: -30 to +35 dBm Uplink: -50 to +15 dBm
	Modulation	GMSK, 8PSK (with MU848060C-01)

*1: Only when two MU848060C TDMA2 units installed

*2: No GSM signal is output from this connector when only one TDMA2 unit is installed.

■ ISDN Specifications: MU848055C ISDN/CSD

Electrical characteristics (interface and others)	BRI 1	ISDN Basic Rate Interface (BRI) 1 Channels: 2B + D (B: 64 kbps, D: 16 kbps) Connector: 8 pin modular connector
	BRI 2	ISDN Basic Rate Interface (BRI) 2 Channels: 2B + D (B: 64 kbps, D: 16 kbps) Connector: 8 pin modular connector
	BRI 3	ISDN Basic Rate Interface (BRI) 3 Channels: 2B + D (B: 64 kbps, D: 16 kbps) Connector: 8 pin modular connector
	Serial	RS-232C Standard serial interface Connector: 9 pin D-Sub connector
Others	Functions	Connection with ISDN terminals.

Software Options				Software Support Contract				Additional Function	No.						
MX848060E	MX848060E-001	MX848060E-002	MX848062C	MX848062C-001	MX848041E*1	MX848041E-10	MX848045C*1								
							MD8480C-SS120	1	1*3	1*4	W-CDMA 1BTS	1			
							MD8480C-SS121								
							MD8480C-SS122		1*2	1*2	1*3	1*4	HSPA 1BTS	2	
							MD8480C-SS123								
							MD8480C-SS124		1*2	1*2	1*3	1*4	2BTS Soft Handover (HSPA)	3	
							MD8480C-SS125		1*2	1*2	1*3	1*4	3BTS Soft Handover (HSPA)	4	
							MD8480C-SS150*2		1*2	1*2	1*3	1*4	4BTS Soft Handover (HSPA)	5	
							MD8480C-SS151*2								
							MD8480C-SS250*2								
							MD8480C-SS251*2								
							Z1217A*3		1*3	1*4			Hard Handover (WCDMA - WCDMA)	6	
							Z1218A*3								
							MC0011A*4		1*3	1*4			Inter System Handover (GSM/GPRS/EGPRS)	7	
									1*3	1*4			Intra-System Handover (GSM/GPRS/EGPRS)	8	
									1*3	1*4			Baseband Interface (W-CDMA)	9	
									1*2	1*2	1*3	1*4	HSPA Evolution (CPC, CS Voice over HSPA etc)	10	
									1*2	1*2	1*3	1*4	DL 64QAM (21 Mbps), UL 16QAM (11 Mbps)	11	
									1*2	1*2	1*3	1*4	MIMO (RF)	12	
									1*2	1*2	1*3	1*4	MIMO (RF+Baseband)	13	
									1*2	1*2	1*3	1*4	Improved L2 for UL/ Enhanced UL for Cell FACH	14	
									1*2	1*2	1*3	1*4	DC-HSDPA	15	
									1*2	1*2	1*3	1*4	64QAM & MIMO	16	
									1*2	1*2	1*3	1*4	DB-DC-HSDPA (Rel-9)	17	
									1*3	1*4			Tx Diversity (1 Antenna W-CDMA)	18	
									1*3	1*4			Tx Diversity (2 Antenna W-CDMA)	19	
									1*2	1*3	1*4		Tx/Rx Diversity (1 Antenna HSPA)	20	
									1*2	1*3	1*4		Tx/Rx Diversity (2 Antenna HSPA)	21	
					1*1					1*3	1*4		Ciphering (W-CDMA)	22	
					1*1	1				1*2	1*2	1*3	1*4	Ciphering (HSPA)	23
									1*1	1				Ciphering (GSM/GPRS)	24
										1*3	1*4		Router Connection (W-CDMA)	25	
										1*3	1*4		RoHC	26	
										1*3	1*4		L3 Message Encoder/ Decoder (W-CDMA)	27	
										1*3	1*4		CSD (W-CDMA)	28	
										1*3	1*4		CSD (GSM)	29	
										1*3	1*4		GSM Frequency Hopping	30	
										1*3	1*4		Dual Transfer Mode (DTM)	31	
										1*3	1*4		Voice Codec (AMR-NB, EFR, FR, HR)	32	
										1*3	1*4		Voice Codec (AMR-WB)	33	
									1*2	1*2	1*3	1*4	WNS (W-CDMA: R99/Rel-5/Rel-6, GSM/GPRS/EGPRS)	34	
									1*2	1*2	1*3	1*4	WNS (Rel-7)	35	
									1*2	1*2	1*3	1*4	WNS (Rel-8)	36	
										1*3	1*4		Support Service (W-CDMA/GSM)	37	
									1	1			Support Service (HSDPA)	38	
										1*2	1*2	1*3	1*4	Support Service (HSUPA)	39
														Your Choice	

- *1: The MX848041A-xx, MX848041C-yy or MX848041E-zz must be ordered when the unit/option is used with MX848001A-xx, MX848001C-yy or MX848001E-zz.
- *2: Package Support Option (supports all systems). This option integrates the MD8480C-SS120, MD8480C-SS121, MD8480C-SS122, MD8480C-SS123, MD8480C-SS124, and MD8480C-SS125.
- *3: Software CD-ROM including latest firmwares and documents.
- *4: The Web Access Key (MC0011A) is for downloading the latest firmware and documents from the Anritsu download website.

Software Options										Software Support Contract										Example of Configuration	No.	
MX848060E	MX848060E-001	MX848060E-002	MX848062C	MX848062C-001	MX848041E*1	MX848041E-10	MX848045C*1	MD8480C-SS120	MD8480C-SS121	MD8480C-SS122	MD8480C-SS123	MD8480C-SS124	MD8480C-SS125	MD8480C-SS150*2	MD8480C-SS151*2	MD8480C-SS250*2	MD8480C-SS251*2	Z1217A*3	Z1218A*3			MC0011A*4
					1*1			1										1*3	1*4		3G W-CDMA Minimum (1BTS) Configuration Package	1
					1*1			1										1*3	1*4		3G W-CDMA SHO/HHO (3BTS) Configuration Package	2
					1*1	1*1	1											1*3	1*4		2G GSM/EGPRS Intra-RAT HO (2BTS) Configuration Package	3
					1*1	1*1	1											1*3	1*4		Dual mode 3G/2G Configuration Package A (for W-CDMA 3BTS & GSM 1BTS)	4
					1*1	1	1*1	1	1									1*3	1*4		Dual mode 3G/2G Configuration Package B (for W-CDMA/HSDPA 3BTS & GSM/EGPRS 1BTS)	5
					1*1	1	1*1							1*2	1*2	1*3	1*4				Dual mode 3G/2G Configuration Package C (for W-CDMA/HSPA Evolution 3BTS & GSM/EGPRS 2BTS)	6
					1*1	1	1*1							1*2	1*2	1*3	1*4				Non-CT PTS Configuration Package (for W-CDMA/HSPA 3BTS & GSM/EGPRS 1BTS)	1
					1*1		1*1	1										1*3	1*4		TS 34.123 GCF Conformance Test Toolkit Configuration Package A (for W-10, 12 & 13)	2
					1*1	1	1*1							1*2	1*2	1*3	1*4				TS 34.123 GCF Conformance Test Toolkit Configuration Package B (for W-10, 12, 13, 14, 24 & 25)	3
					1*1	1	1*1							1*2	1*2	1*3	1*4				TS 34.123 GCF Conformance Test Toolkit Configuration Package C (for Rel. 99 to Rel. 7)	4
					1*1	1	1*1							1*2	1*2	1*3	1*4				AT & T IOT Library Configuration Package	1

Standalone MD8480C

PTS/PCT

RTD

																						1
																						2
																						3
																						4
																						5
																						6
																						7
																						8

Customer's Configuration

*1: The MX848041A-xx, MX848041C-yy or MX848041E-zz must be ordered when the unit/option is used with MX848001A-xx, MX848001C-yy or MX848001E-zz.
 *2: Package Support Option (supports all systems).
 This option integrates the MD8480C-SS120, MD8480C-SS122, MD8480C-SS123, MD8480C-SS124, and MD8480C-SS125.
 *3: Software CD-ROM including latest firmwares and documents.
 *4: The Web Access Key (MC0011A) is for downloading the latest firmware and documents from the Anritsu download website.

• **United States**

Anritsu Company

1155 East Collins Blvd., Suite 100, Richardson,
TX 75081, U.S.A.
Toll Free: 1-800-267-4878
Phone: +1-972-644-1777
Fax: +1-972-671-1877

• **Canada**

Anritsu Electronics Ltd.

700 Silver Seven Road, Suite 120, Kanata,
Ontario K2V 1C3, Canada
Phone: +1-613-591-2003
Fax: +1-613-591-1006

• **Brazil**

Anritsu Eletrônica Ltda.

Praça Amadeu Amaral, 27 - 1 Andar
01327-010 - Bela Vista - São Paulo - SP - Brazil
Phone: +55-11-3283-2511
Fax: +55-11-3288-6940

• **Mexico**

Anritsu Company, S.A. de C.V.

Av. Ejército Nacional No. 579 Piso 9, Col. Granada
11520 México, D.F., México
Phone: +52-55-1101-2370
Fax: +52-55-5254-3147

• **United Kingdom**

Anritsu EMEA Ltd.

200 Capability Green, Luton, Bedfordshire, LU1 3LU, U.K.
Phone: +44-1582-433200
Fax: +44-1582-731303

• **France**

Anritsu S.A.

12 avenue du Québec, Bâtiment Iris 1- Silic 612,
91140 VILLEBON SUR YVETTE, France
Phone: +33-1-60-92-15-50
Fax: +33-1-64-46-10-65

• **Germany**

Anritsu GmbH

Nemetschek Haus, Konrad-Zuse-Platz 1
81829 München, Germany
Phone: +49-89-442308-0
Fax: +49-89-442308-55

• **Italy**

Anritsu S.r.l.

Via Elio Vittorini 129, 00144 Roma, Italy
Phone: +39-6-509-9711
Fax: +39-6-502-2425

• **Sweden**

Anritsu AB

Borgarfjordsgatan 13A, 164 40 KISTA, Sweden
Phone: +46-8-534-707-00
Fax: +46-8-534-707-30

• **Finland**

Anritsu AB

Teknobulevardi 3-5, FI-01530 VANTAA, Finland
Phone: +358-20-741-8100
Fax: +358-20-741-8111

• **Denmark**

Anritsu A/S (Service Assurance)

Anritsu AB (Test & Measurement)

Kay Fiskers Plads 9, 2300 Copenhagen S, Denmark
Phone: +45-7211-2200
Fax: +45-7211-2210

• **Russia**

Anritsu EMEA Ltd.

Representation Office in Russia

Tverskaya str. 16/2, bld. 1, 7th floor.

Russia, 125009, Moscow
Phone: +7-495-363-1694
Fax: +7-495-935-8962

• **United Arab Emirates**

Anritsu EMEA Ltd.

Dubai Liaison Office

P O Box 500413 - Dubai Internet City
Al Thuraya Building, Tower 1, Suit 701, 7th Floor
Dubai, United Arab Emirates
Phone: +971-4-3670352
Fax: +971-4-3688460

• **India**

Anritsu India Private Limited

2nd & 3rd Floor, #837/1, Binnamangla 1st Stage,
Indiranagar, 100ft Road, Bangalore - 560038, India
Phone: +91-80-4058-1300
Fax: +91-80-4058-1301

• **Singapore**

Anritsu Pte. Ltd.

60 Alexandra Terrace, #02-08, The Comtech (Lobby A)
Singapore 118502
Phone: +65-6282-2400
Fax: +65-6282-2533

• **P.R. China (Shanghai)**

Anritsu (China) Co., Ltd.

Room 1715, Tower A CITY CENTER of Shanghai,
No.100 Zunyi Road, Chang Ning District,
Shanghai 200051, P.R. China
Phone: +86-21-6237-0898
Fax: +86-21-6237-0899

• **P.R. China (Hong Kong)**

Anritsu Company Ltd.

Unit 1006-7, 10/F., Greenfield Tower, Concordia Plaza,
No. 1 Science Museum Road, Tsim Sha Tsui East,
Kowloon, Hong Kong, P.R. China
Phone: +852-2301-4980
Fax: +852-2301-3545

• **Japan**

Anritsu Corporation

8-5, Tamura-cho, Atsugi-shi, Kanagawa, 243-0016 Japan
Phone: +81-46-296-1221
Fax: +81-46-296-1238

• **Korea**

Anritsu Corporation, Ltd.

502, 5FL H-Square N B/D, 681
Sampyeong-dong, Bundang-gu, Seongnam-si,
Gyeonggi-do, 463-400 Korea
Phone: +82-31-696-7750
Fax: +82-31-696-7751

• **Australia**

Anritsu Pty. Ltd.

Unit 21/270 Ferntree Gully Road, Notting Hill,
Victoria 3168, Australia
Phone: +61-3-9558-8177
Fax: +61-3-9558-8255

• **Taiwan**

Anritsu Company Inc.

7F, No. 316, Sec. 1, NeiHu Rd., Taipei 114, Taiwan
Phone: +886-2-8751-1816
Fax: +886-2-8751-1817

Please Contact: