

High-power Programmable DC Electronic Load



FT6804 2.6 kW/100A/500V

- Voltage range: 40 V, 120 V, 500 V, 800 V, 1000 V, 1200 V;
- Current range: 2400A max. per unit;
- Rated power: 2.6kW, 4kW, 5.2kW, 8kW, 12kW, 16kW, 20kW, 24kW, 28kW, 32kW, 36kW, 42kW, 48kW, 52kW, max. 300kW (parallel);
- CC, CV, CR, CP, CV+CC, CR+CC modes;
- Dynamic frequency up to 20kHz;
- Ultra high precision V & I measurement;
- Store and recall up to 20 groups setups;
- Flexible triggering options via front panel, external input, or bus (used for transient, sequence, automatic test);
- Adjustable CV loop speed test, match different power supplies;
- Programmable sequence , automatic test;
- OCP test, super capacitor test, battery test;
- Short circuit simulation;
- Voltage-on (Von) & voltage-off (Voff) operation and timer unloading;
- Analog interfaces provides current programming and voltage/current monitoring;
- ±OVP, ±OCP, ±OPP, OTP, ±current limit;
- Standard RS232, USB (serial), LAN, optional GPIB interface;
- SCPI and ModBus RTU protocol;

General

FT6800 series high-power programmable DC electronic load is a multi-functional, large-capacity electronic load product designed with the principle of high reliability and high stability. FT6800 series has the advantages of fast transient response, high precision (0.05% accuracy), capability of low voltage operation at full scale current, they are widely used in testing and evaluating a variety of DC sources such as DC-DC converters, power batteries, solar cell array, BMS, charging piles, charging pile modules, vehicle On Board chargers (OBC), high-power switching power supplies, telecom power supply, vehicle power supply, super capacitor, etc.

For bench top applications, this series provides an intuitive user interface with full keypad and rotary knob. System integrators benefit from the standard USB (virtual SERIAL), RS232 and LAN interfaces supporting both SCPI commands and ModBus RTU protocol. The optional Windows application software allows users to control the electronic load, execute various tests such as sequence test, automatic test, dynamic test, static test, OCP/OVP/OPP test, battery discharging test etc...

FT6800 Series (2.6 kW...52 kW)

Transient test

Modern electronic devices operate at very high speeds and demand rapid transient response characteristics. To address these applications, the series offers high speed, programmable dynamic current loading. The figure shown below exhibits the programmable parameters such as current high/low level, T1/T2, rise/fall rate. The dynamic loading supports continuous, pulse, and toggle modes. When configured as pulse or toggle mode, the load accepts a trigger signal via front panel, external input, or bus, which allow the dynamic load behavior to be synchronized with other events. The max. current rise rate is 60 A/ μ s and the dynamic change is up to 20kHz.

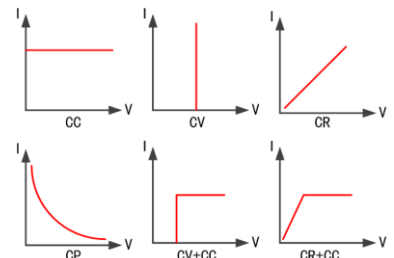
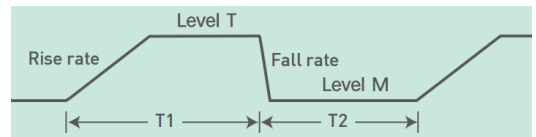

Static test

In addition to the basic test modes of CC, CV, CR, CP, the series load provides users with CV+CC and CR+CC complex modes to meet comprehensive test requirements (complex modes are unavailable for 40V voltage models).

Programmable sequence test

All models provides users with a programmable sequence function to simulate various load input changes. The sequence feature allows users to program a list of steps to the electronic load's internal memory and execute them. A total of 50 steps can be allocated to each internal memory location, up to a maximum of 20 locations (sequences). The test sequence can be programmed locally through the keypad and rotary knob, also it can be programmed remotely via the USB, GPIB, or LAN interfaces using SCPI commands with the included application software. Each steps' settings include operate mode (CC/CV/CR/CP), range, load value, step time (0.0001 ~ 90000 seconds), rise slew rate, fall slew rate. Sequence files can be run continuously, or by trigger signal.

OCP test

All models provides OCP test feature, which enables the user to set current orders to test overcurrent protections, also to judge the test result as Pass or Fail on electronic load. The maximum current (I_{max}) during testing can be captured and showed on the display without using an oscilloscope to verify the correctness of designed overcurrent. It can save a lot of testing time for the user. Furthermore, users can collaborate with remote control software to conduct OCP/OVP/OPP test.

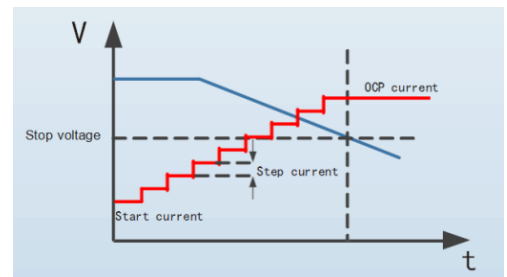

Automatic test

The automatic test feature allows users to program a list of steps to the load's internal memory and execute them. A total of 50 steps can be allocated to each internal memory location, up to a maximum of 20 locations (test files). The test file can be programmed locally through the keypad and rotary knob, also it can be programmed remotely via the USB, GPIB, or LAN interfaces using SCPI commands with the included application software. Each steps' settings include operate mode (CC/CV/CR/CP), range, load value, step time (0.2 ~ 25.5 seconds), short circuit status (ON/OFF), judge parameter (OFF / V / I / P), lower limit, upper limit. The load can compare the test parameters with corresponding upper and lower limits, and display the test results in the form of NG/GO. This feature greatly improves the test efficiency.

Battery internal resistance and capacity test

Internal resistance test adopts constant current discharging method.

For battery capacity test, it adopts transient current discharging, in which the discharging current is switching between main value (LEVEL M) and transient value (LEVEL T). When transient current LEVEL M equals LEVEL T, it turns into constant current discharging method. Users can set cut off voltage, discharging current (LEVEL M & LEVEL T), discharging time (WIDTH M & WIDTH T) for capacity test.

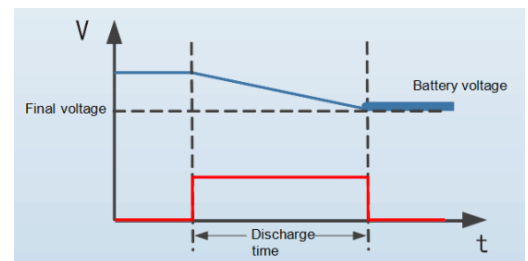

Super capacitor test

The series can test the internal resistance and capacity of the super capacitor at the same time. You can test the super capacitor by setting the discharge current, cut off voltage, and the start/end points of the capacity calculation. The test terminates when the super capacitor voltage drops to cut off voltage, the capacity and ESR value of super capacitor will be displayed on the TFT screen.

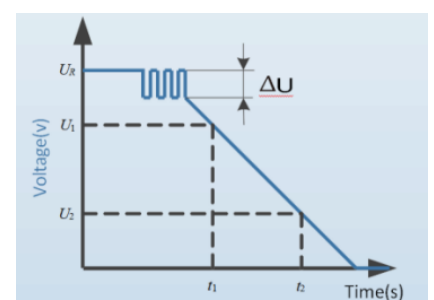

FT6800 Series (2.6 kW...52 kW)

Master-slave parallel

For increased power and current, two or more loads can be run in parallel to achieve the desired power and load current. All models provides the user with smart Master-Slave parallel controls, which enables the user to program the load currents of the Master unit and have them automatically calculated and distributed to the slave loads. Using several loads in parallel to simulate a single load dramatically simplifies the operation. All models of the series can be integrated into a 19" width standard rack to save space, as well as controlled and reconfigured with automated testing applications via standard RS232 and GPIB interfaces.

Voltage-on (Von) & voltage-off (Voff) operation and timer unloading

In static mode (CC, CV, CP and CP) operation, users are able to control the input turn on/off state for the DC electronic load by configuring the Von/Voff function. Also this series provides users with a timer unloading function, the electronic load automatically turns off loading when time finishes.

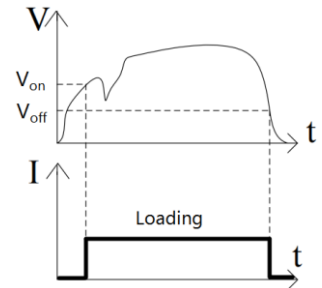

Low voltage operation

The FT6800 series can operate at low voltages for high current applications such as testing of superconducting material, solar cell, fuel cell, CPU power supply circuit, etc..

FT6826N	FT6840N	FT6880N	FT68120N
0.2V/400A	0.2V/600A	0.3V/1200A	0.3V/1500A

Protective features

For protection of the equipment connected, it is possible to set an overvoltage protection threshold (OVP), as well as one for overcurrent (OCP) and overpower (OPP). As soon as one of these thresholds is reached for any reason, the loading will be immediately shut off and a status signal will be prompt on the display and via the interfaces. There is furthermore an overtemperature protection (OTP), which will shut off the loading if the power supply overheats.

External analog programming and monitoring

In addition to front panel and remote interface control, current values can also be programmed from 0...100% with an analog control signal of 0 V...10 V (available in CC mode only). To monitor the input voltage and current, there are analog outputs with 0 V...10 V.

Digital interfaces

In addition to the local controls through full keypad rotary knob, there are standard remote control interfaces such as USB, RS232 and LAN interfaces. USB, RS232 and LAN can be used to control and monitor the devices either with SCPI language commands or ModBus RTU protocol, while with GPIB only SCPI is supported.

Optional control software

Faithtech provides an optional control software for Windows PCs, which allows for the user to remotely control the power supply, execute various tests such as sequence test, automatic test, dynamic test, static test, OCP/OVP/OPP test, battery discharging test. Furthermore, the control software allows user to conduct parallel operations (Software parallel operations are available via RS232 and GPIB interfaces ONLY).

Options

FT68001A graphical visualization control software FaithLoad;
AC load rectifier accessories.

FT6800 Series (2.6 kW...52 kW)
Model options

Model	Specification	Model	Specification	Model	Specification
FT6803B	2.6kW/300A/120V	FT68020A	20kW/900A/120V	FT68036A	36kW/1kA/120V
FT6804B	2.6kW/100A/500V	FT68020B	20kW/500A/500V	FT68036B	36kW/800A/500V
FT6805B	4kW/300A/120V	FT68020C	20kW/400A/800V	FT68036C	36kW/640A/800V
FT6806B	4kW/100A/500V	FT68020D	20kW/400A/1kV	FT68036D	36kW/640A/1kV
FT6807B	5.2kW/600A/120V	FT68020E	20kW/300A/1.2kV	FT68036E	36kW/480A/1.2kV
FT6808B	5.2kW/200A/500V	FT68024A	24kW/900A/120V	FT68042A	42kW/1.2kA/120V
FT6809B	5.2kW/60A/800V	FT68024B	24kW/600A/500V	FT68042B	42kW/800A/500V
FT6810B	8kW/600A/120V	FT68024C	24kW/480A/800V	FT68042C	42kW/640A/800V
FT6811B	8kW/200A/500V	FT68024D	24kW/480A/1kV	FT68042D	42kW/640A/1kV
FT6812B	8kW/160A/800V	FT68024E	24kW/360A/1.2kV	FT68042E	42kW/480A/1.2kV
FT6813B	8kW/160A/1000V	FT68028A	28kW/1kA/120V	FT68048A	48kW/1.2kA/120V
FT6814B	12kW/600A/120V	FT68028B	28kW/700A/500V	FT68048B	48kW/900A/500V
FT6815B	12kW/300A/500V	FT68028C	28kW/560A/800V	FT68048C	48kW/720A/800V
FT6817B	12kW/240A/800V	FT68028D	28kW/560A/1kV	FT68048D	48kW/720A/1kV
FT6818B	12kW/240A/1kV	FT68028E	28kW/420A/1.2kV	FT68048E	48kW/540A/1.2kV
FT6819B	12kW/180A/1.2kV	FT68032A	32kW/1kA/120V	FT68052A	52kW/1.2kA/120V
FT68016A	16kW/900A/120V	FT68032B	32kW/800A/500V	FT68052B	52kW/1kA/500V
FT68016B	16kW/400A/500V	FT68032C	32kW/640A/800V	FT68052C	52kW/720A/800V
FT68016C	16kW/320A/800V	FT68032D	32kW/640A/1kV	FT68052D	52kW/720A/1kV
FT68016D	16kW/320A/1kV	FT68032E	32kW/480A/1.2kV	FT68052E	52kW/540A/1.2kV
FT68016E	16kW/240A/1.2kV				

Optional accessories table 1

Item	Type	Notes
Host PC software	FT68001A	
AC load rectifier	MD220-50	80~260Vac/50A single phase input
AC load rectifier	MD220-100	80~260Vac/100A single phase input
AC load rectifier	MD380-100	190~450Vac/100A three phase input
AC load rectifier	MD220-200	190~450Vac/200A three phase input

Optional accessories table 2: High current test cable matching table

Specification	DC2-2P15M	DC16-2P20M	DC25-2P25M	DC50-2P20M	DC50-2P40M	DC120-2P20M	DC150-2P20M
Max voltage	750V						
Max current	10A	60A	100A	200A	200A	300A	400A
Terminal	M8/Alligator	M8/M8	M8/M8	M8/M8	M8/M8	M8/M8	M10/M10
Cross-sectional area	4.0mm ²	16mm ²	25mm ²	50mm ²	50mm ²	120mm ²	150mm ²
Length	~1.5m	~2m	~2m	~2m	~4m	~2m	~2m
Shape							

FT6800 Series (2.6 kW...52 kW)

Specification - 1								
Model	FT6826N		FT6840N		FT6880N		FT68120N	
Voltage	40V		40V		40V		40V	
Current	400A		600A		1200A		1500A	
Power	2,600W		4,000W		8,000W		12,000W	
U _{Min} for I _{Max}	0.2V/400A		0.2V/600A		0.3V/1200A		0.3V/1500A	
Constant Current (CC)								
Range	0-40A	0-400A	0-60A	0-600A	0-120A	0-1200A	0-150A	0-1500A
Resolution	0.7mA	8mA	1mA	10mA	2mA	20mA	2.5mA	25mA
Accuracy	0.1%+0.1%F.S.		0.1%+0.1%F.S.		0.1%+0.1%F.S.		0.1%+0.1%F.S.	
Constant Voltage (CV)								
Range	0-40V		0-40V		0-40V		0-40V	
Resolution	0.7mV		0.7mV		0.5mV		0.7mV	
Accuracy	0.05%+0.05%F.S.		0.05%+0.05%F.S.		0.05%+0.05%F.S.		0.05%+0.05%F.S.	
Constant Power (CP)								
Range	0-2,600W		0-4,000W		0-8,000W		0-12,000W	
Resolution	50mW		70mW		140mW		200mW	
Accuracy	0.5%+1%F.S.		0.2%+0.3%F.S.		0.2%+0.3%F.S.		0.2%+0.3%F.S.	
Constant Resistance (CR)								
Range	0.064~512Ω		0.013~107Ω		0.007~54Ω		0.006~44Ω	
Resolution	0.35%+0.006 S		0.35%+0.03 S		0.35%+0.06 S		0.35%+0.07 S	
Accuracy	16 bits		16 bits		16 bits		16 bits	
Slew Rate								
I Slew Rate	1-80A/ms	80-4000A/ms	1.5-120A/ms	120-6000A/ms	3-240A/ms	240-12000A/ms	3-300A/ms	300-15000A/ms
V Slew Rate	0.3-16V/ms	16-160V/ms	0.3-16V/ms	16-160V/ms	0.3-16V/ms	16-160V/ms	0.3-16V/ms	16-160V/ms
P Slew Rate	1-80A/ms	80-4000A/ms	1.5-120A/ms	120-6000A/ms	3-240A/ms	240-12000A/ms	3-300A/ms	300-15000A/ms
R Slew Rate	1-80A/ms	80-4000A/ms	1.5-120A/ms	120-6000A/ms	3-240A/ms	240-12000A/ms	3-300A/ms	300-15000A/ms
Voltage Measurement								
Range	0-40V		0-40V		0-40V		0-40V	
Resolution	16 bits		16 bits		16 bits		16 bits	
Accuracy	0.025%+0.025%F.S.		0.025%+0.025%F.S.		0.025%+0.025%F.S.		0.025%+0.025%F.S.	
Current Measurement								
Range	0-40A	0-400A	0-60A	0-600A	0-120A	0-1200A	0-150A	0-1500A
Resolution	16 bits		16 bits		16 bits		16 bits	
Accuracy	0.1%+0.1%F.S.		0.1%+0.1%F.S.		0.1%+0.1%F.S.		0.1%+0.1%F.S.	
Power Measurement								
Range	0-2,600W		0-4,000W		0-8,000W		0-12,000W	
Resolution	16 bits		16 bits		16 bits		16 bits	
Accuracy	0.5%+1%F.S.		0.5%+1%F.S.		0.2%+0.3%F.S.		0.2%+0.3%F.S.	
Transient Measurement								
T1&T2	0.025-60ms	1-6000ms	0.025-60ms	1-6000ms	0.025-60ms	1-6000ms	0.025-60ms	1-6000ms
Resolution	1us	1ms	1us	1ms	1us	1ms	1us	1ms
Accuracy	1us+100ppm	1ms+100ppm	1us+100ppm	1ms+100ppm	1us+100ppm	1ms+100ppm	1us+100ppm	1ms+100ppm
Size (W*H*D)	440×200×630 mm		440×200×630 mm		440×420×680 mm		440×600×630 mm	
Temperature	Protection temperature 85°C, working ambient temperature 0~40°C, full power operation ambient temperature 0~25°C							

FT6800 Series (2.6 kW...52 kW)

Specification - 2								
Model	FT6803B		FT6804B		FT6805B		FT6806B	
Voltage	120V		500V		120V		500V	
Current	300A		100A		300A		100A	
Power	2600W		2600W		4000W		4000W	
U _{Min} for I _{Max}	2V/300A		4.5V/100A		2V/300A		4.5V/100A	
Constant Current (CC)								
Range	0-30A	0-300A	0-10A	0-100A	0-30A	0-300A	0-10A	0-100A
Resolution	0.5mA	5mA	0.2mA	2mA	0.6mA	6mA	0.2mA	2mA
Accuracy	0.1%+0.15%F.S	0.05%+0.1%F.S	0.1%+0.15%F.S	0.05%+0.1%F.S	0.1%+0.15%F.S	0.05%+0.1%F.S	0.1%+0.15%F.S	0.05%+0.1%F.S
Constant Voltage (CV)								
Range	0-12V	0-120V	0-50V	0-500V	0-12V	0-120V	0-50V	0-500V
Resolution	0.2mV	2mV	1mV	10mV	0.2mV	2mV	1mV	10mV
Accuracy	0.05%+0.05%.S.							
Constant Power (CP)								
Range	0-2600W		0-2600W		0-4000W		0-4000W	
Resolution	50mW		50mW		70mW		70mW	
Accuracy	0.5%+1%F.S.		0.5%+1%F.S.		0.2%+0.3%F.S.		0.2%+0.3%F.S.	
Constant Resistance (CR)								
Range	0.004~40Ω	0.08~640Ω	0.05~500Ω	1~8000Ω	0.004~40Ω	0.08~640Ω	0.05~500Ω	1~8000Ω
Accuracy	0.01%+0.075S	0.01%+0.005S	0.01%+0.0062S	0.01%+0.0004S	0.01%+0.083S	0.01%+0.0052S	0.01%+0.025S	0.01%+420uS
Resolution	16bits							
Slew Rate								
I Slew Rate	5-300A/ms	300-15000A/ms	1-100A/ms	100-5000A/ms	5-300A/ms	300-15000A/ms	1-100A/ms	100-5000A/ms
V Slew Rate	1.0-50V/ms	50-500V/ms	4.0-200V/ms	200-2000V/ms	1.0-50V/ms	50-500V/ms	4.0-200V/ms	200-2000V/ms
P Slew Rate	5-300A/ms	300-15000A/ms	1-100A/ms	100-5000A/ms	5-300A/ms	300-15000A/ms	1-100A/ms	100-5000A/ms
R Slew Rate	5-300A/ms	300-15000A/ms	1-100A/ms	100-5000A/ms	5-300A/ms	300-15000A/ms	1-100A/ms	100-5000A/ms
Accuracy	(1±35%) * Set value							
Voltage Measurement								
Range	0-12V	0-120V	0-50V	0-500V	0-12V	0-120V	0-50V	0-500V
Accuracy	0.025%+0.025%F.S.							
Current Measurement								
Range	0-30A	0-300A	0-10A	0-100A	0-30A	0-300A	0-10A	0-100A
Accuracy	0.1%+0.15%F.S	0.05%+0.1%F.S	0.1%+0.15%F.S	0.05%+0.1%F.S	0.1%+0.15%F.S	0.05%+0.1%F.S	0.1%+0.15%F.S	0.05%+0.1%F.S
Power Measurement								
Range	0-2600W		0-2600W		0-4000W		0-4000W	
Accuracy	0.2%+0.3%F.S							
Dynamic								
T1&T2	0.025-60ms	1-60000ms	0.025-60ms	1-60000ms	0.025-60ms	1-60000ms	0.025-60ms	1-60000ms
Resolution	1us	1ms	1us	1ms	1us	1ms	1us	1ms
Accuracy	1us+100ppm	1ms+100ppm	1us+100ppm	1ms+100ppm	1us+100ppm	1ms+100ppm	1us+100ppm	1ms+100ppm
Dimension	440(W)×200(H)×630(D)							
Temperature	Protection temperature 85°C, working ambient temperature 0~40°C, full power operation ambient temperature 0~25°C							

FT6800 Series (2.6 kW...52 kW)

Specification - 3								
Model	FT6807B		FT6808B		FT6810B		FT6811B	
Voltage	120V		500V		120V		500V	
Current	600A		200A		600A		200A	
Power	5200W		5200W		8000W		8000W	
U _{Min} for I _{Max}	2.5V/600A		4.5V/200A		2.5V/600A		4.5V/200A	
Constant Current (CC)								
Range	0-60A	0-600A	0-20A	0-200A	0-60A	0-600A	0-20A	0-200A
Resolution	1mA	10mA	0.4mA	4mA	1mA	10mA	0.4mA	4mA
Accuracy	0.1%+0.15%F.S.	0.1%+0.1%F.S.	0.1%+0.15%F.S.	0.1%+0.1%F.S.	0.1%+0.15%F.S.	0.1%+0.1%F.S.	0.1%+0.15%F.S.	0.1%+0.1%F.S.
Constant Voltage (CV)								
Range	0-12V	0-120V	0-50V	0-500V	0-12V	0-120V	0-50V	0-500V
Resolution	0.2mV	2mV	1mV	10mV	0.2mV	2mV	1mV	10mV
Accuracy	0.05%+0.05%F.S.							
Constant Power (CP)								
Range	0-5200W		0-5200W		0-8000W		0-8000W	
Resolution	90mW		90mW		140mW		140mW	
Accuracy	0.2%+0.3%F.S.							
Constant Resistance (CR)								
Range	0.002~20Ω	0.04~320Ω	0.025~250Ω	0.5~4000Ω	0.002~20Ω	0.04~320Ω	0.025~250Ω	0.5~4000Ω
Accuracy	0.01%+0.15S	0.01%+0.01S	0.01%+0.12S	0.01%+830uS	0.01%+0.15S	0.01%+0.01S	0.01%+0.012S	0.01%+830uS
Resolution	16bits							
Slew Rate								
I Slew Rate	10-600A/ms	600-30000A/ms	3.2-160A/ms	160-8000A/ms	10-600A/ms	600-30000A/ms	4-200A/ms	200-10000A/ms
V Slew Rate	1.0-50V/ms	50-500V/ms	4.0-200V/ms	200-2000V/ms	1-50V/ms	50-500V/ms	4-200V/ms	200-2000V/ms
P Slew Rate	10-600A/ms	600-30000A/ms	3.2-160A/ms	160-8000A/ms	10-600A/ms	600-30000A/ms	4-200A/ms	200-10000A/ms
R Slew Rate	10-600A/ms	600-30000A/ms	3.2-160A/ms	160-8000A/ms	10-600A/ms	600-30000A/ms	4-200A/ms	200-10000A/ms
Accuracy	(1±35%) * Set value							
Voltage Measurement								
Range	0-12V	0-120V	0-50V	0-500V	0-12V	0-120V	0-50V	0-500V
Accuracy	0.025%+0.025%F.S.							
Current Measurement								
Range	0-60A	0-600A	0-20A	0-200A	0-60A	0-600A	0-20A	0-300A
Accuracy	0.1%+0.15%F.S.	0.1%+0.1%F.S.	0.1%+0.15%F.S.	0.1%+0.1%F.S.	0.1%+0.15%F.S.	0.1%+0.1%F.S.	0.1%+0.15%F.S.	0.1%+0.1%F.S.
Power Measurement								
Range	0-5200W		0-5200W		0-8000W		0-8000W	
Accuracy	0.2%+0.3%F.S.							
Transient Measurement								
T1&T2	0.025-60ms	1-60000ms	0.025-60ms	1-60000ms	0.025-60ms	1-60000ms	0.025-60ms	1-60000ms
Resolution	1us	1ms	1us	1ms	1us	1ms	1us	1ms
Accuracy	1us+100ppm	1ms+100ppm	1us+100ppm	1ms+100ppm	1us+100ppm	1ms+100ppm	1us+100ppm	1ms+100ppm
Dimension	440(W)×420(H)×680(D)							
Temperature	Protection temperature 85°C, working temperature 0~40°C, full power operation temperature 0~25°C							

FT6800 Series (2.6 kW...52 kW)

Dimension *

2.6kW~4kW model dimension

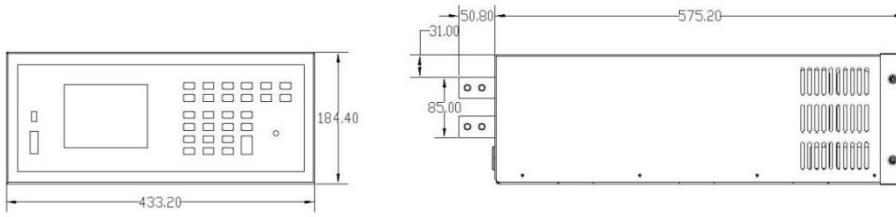

5.2kW~8kW model dimension

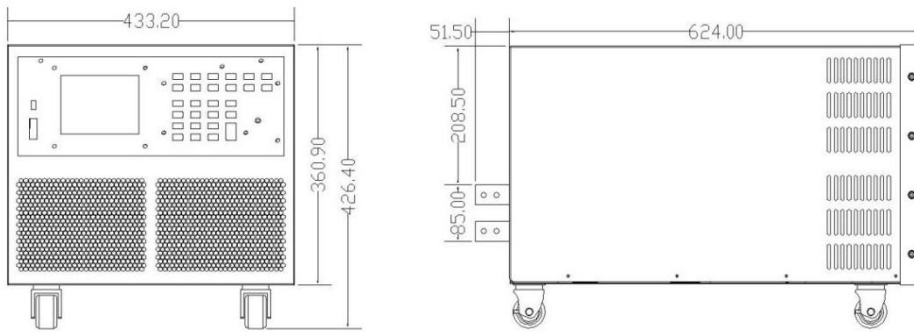

12kW model dimension

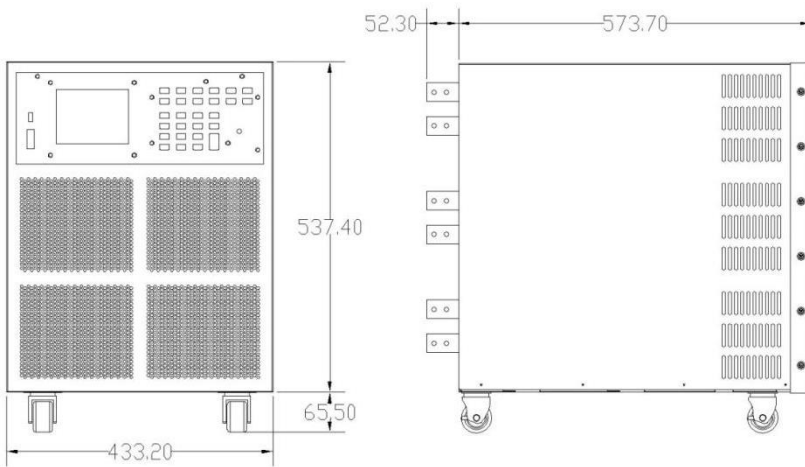

* Specifications are subject to changes without notice.

Made in broke – Impasse des Colchiques, 31150 Fenouillet – Tel: 05 62 79 15 14 – contact@madeinbroke.com