

# Product Data

## Power Amplifier — Type 2706

### USES:

- To drive the Vibration Exciter Type 4809
- To drive the Mini-Shaker Type 4810 safely to full rating
- General purpose power amplifier, supplying for example 75 W into a 3Ω loudspeaker for reverberation measurements

### FEATURES:

- 75 VA power output capability
- Switchable 5 A or 1.8 A max. current limiting
- 40 dB voltage gain
- Built-in attenuator and continuously variable gain control
- Low distortion over wide frequency range
- Built-in protection against short-circuit and excess heat sink temperature
- Front panel indicator light showing clipped output signal

The Power Amplifier Type 2706 has been designed to drive small vibration exciters, particularly the Brüel & Kjær Vibration Exciter Type 4809. It can also be used to drive the Mini-Shaker Type 4810 to full rating. For this application, the maximum output current should be limited to 1.8 A.

The power amplifier has a flat frequency response from 10 Hz to 20 kHz ( $\pm 0.5$  dB). The power output capability is 75 VA into a 3Ω exciter or resistive load and the maximum voltage gain is 40 dB. This enables the power amplifier to be used in acoustical measurement set-ups, even when third-octave narrow band noise is employed.

The use of a transformerless power output stage and high negative feedback results in very low harmonic distortion. A balanced preamplifier and rugged solid-state design results in a stable instrument which can tolerate temperature fluctuations and supply line variations.

### Description

The block diagram for the various circuit functions is shown in Fig. 1.

The input circuitry includes an attenuator for attenuation of the input signal in 10 dB steps from 0 to 40 dB. This is followed by a continuously

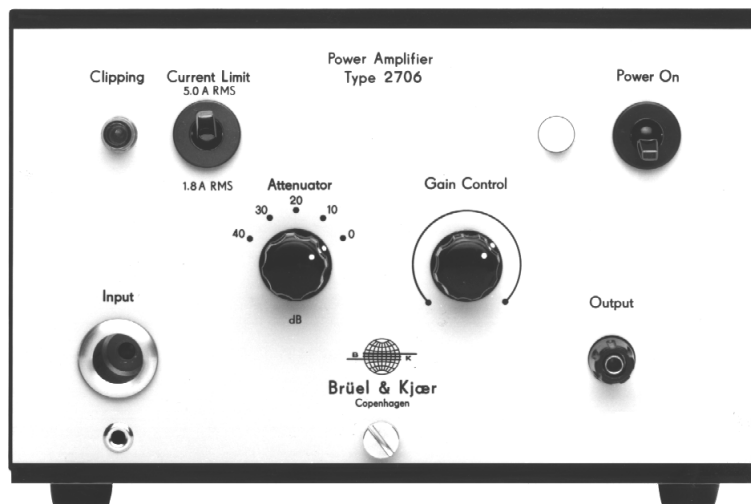

951140e

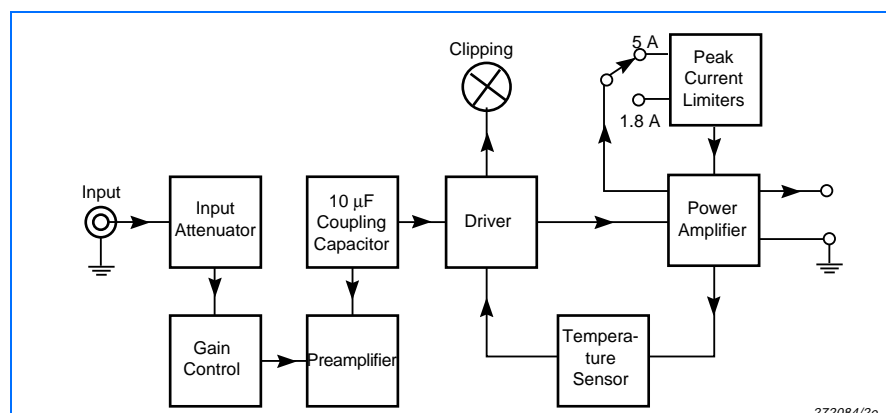

272084/2e

Fig. 1 Block diagram of Power Amplifier Type 2706

variable gain control and a preamplifier. The preamplifier is capacitively coupled to the driver stage, which is equipped with a clipping detector. Excessive signal levels at the input will saturate the amplifier and cause clipping of the output waveform. This will trigger the clipping detector, which then lights the yellow clipping warning light on the front panel. The instrument remains in operation during clipping.

The power stage employs an output current limiter, which limits the instantaneous positive and negative peaks of the output current. The power output stage is protected by a temperature sensing device. Abnormal load conditions, high ambient temperatures or an output short-circuit could result in output transistor temperatures well in excess of design limits. To prevent any subsequent damage, the temperature protective circuitry blocks the amplifier input signal. When the heat-sink temperature reverts to the normal level the power amplifier will automatically regain operation.

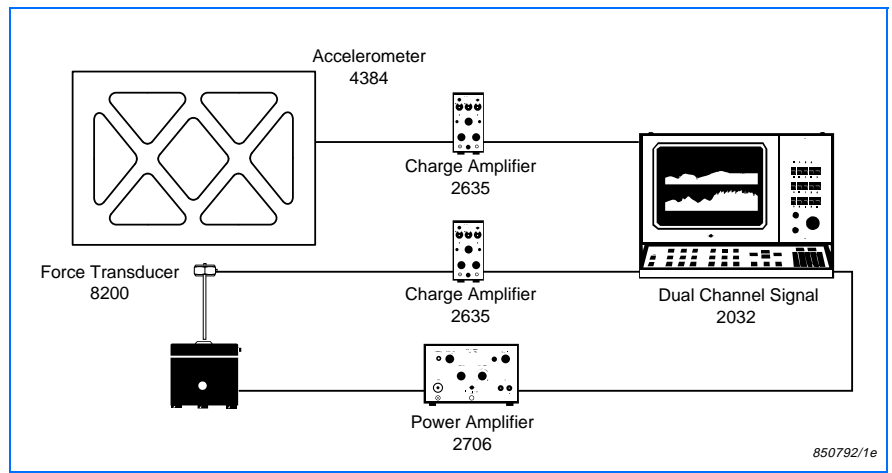

Fig. 2 Typical frequency response test set-up

### Example Of Set-Up

A typical frequency response test set-up for vibration testing is shown in Fig. 2.

An input forcing signal is taken directly from the Signal Analyzer Type 2032 and is fed to the power

amplifier which drives the Vibration Exciter Type 4809. The signal analyzer measures the input forcing signal and the structural response signal and uses them to produce a representation of frequency response function of the structure under test.

# Specifications 2706

## POWER OUTPUT CAPABILITY:

75 VA into 3Ω exciter or resistive load

## CURRENT LIMITING:

Switchable,  
Max. 5 A for Vibration Exciter Type 4809  
Max. 1.8 A for Mini-Shaker Type 4810

## FREQUENCY RESPONSE:

10 Hz to 20 kHz ( $\pm 0.5$  dB)  
2 Hz to 50 kHz ( $\pm 3$  dB)

## HARMONIC DISTORTION:

<0.2% (20 Hz to 10 kHz)  
<0.5% (20 Hz to 20 kHz)  
at full output capacity

## INPUT IMPEDANCE:

15 kΩ

## OUTPUT IMPEDANCE:

<0.04 Ω (10 Hz to 5 kHz)  
<0.08 Ω (5 kHz to 20 kHz)

## PROTECTION:

Short circuit  
Excessive heat sink temperature  
Input overload

## DC STABILITY:

<25 mV drift for  $\pm 5\%$  supply line variation  
<25 mV drift for ambient temperature variations  
between 10 and 40 °C (50 and 104 °F)

## HUM AND NOISE:

<5 mV RMS

## MAX. VOLTAGE GAIN AT 1 KHZ:

40 dB ( $\pm 1$  dB)

## ATTENUATOR:

0 to 40 dB in 10 dB steps

## GAIN CONTROL:

0 to -x dB logarithmic

## POWER REQUIREMENTS:

110, 115, 127, 220 and 240 V AC ( $\pm 5\%$ , 50 to 60 Hz)  
Approximately 140 VA  
Complies with safety class 1 of IEC 348

## DIMENSIONS:

**Height:** 133 mm (5.2 in)  
**Width:** 210 mm (8.3 in)  
**Depth:** 240 mm (9.5 in)  
(KK 0042 Cabinet, 6/12 of 19 in rack module)

## WEIGHT:

6 kg (13.2 lb)

## COMPLIANCE WITH STANDARDS:

<b>CE</b>	CE-mark indicates compliance with: EMC Directive and Low Voltage Directive.
<b>Safety</b>	IEC 348: Safety Requirements for Electronic Apparatus
<b>EMC Emission</b>	EN 50081-1: Generic emission standard. Part 1: Residential, commercial and light industry. EN 50081-2: Generic emission standard. Part 2: Industrial environment. CISPR 22: Limits and methods of radio disturbance characteristics of information technology equipment. Class B Limits. FCC Rules, Part 15: Complies with the limits for a Class B digital device.
<b>EMC Immunity</b>	EN 50082-1: Generic immunity standard. Part 1: Residential, commercial and light industry. EN 50082-2: Generic immunity standard. Part 2: Industrial environment. <b>Note 1:</b> The above is guaranteed using accessories listed in this Product Data sheet only. <b>Note 2:</b> RF disturbances above 3 MHz may result in demodulation and overload conditions.
<b>Temperature</b>	IEC 68-2-1 & IEC 68-2-2: Environmental Testing. Cold and Dry Heat. Operating Temperature: +5 to +40°C (41 to 104°F) Storage Temperature: -25 to +70°C (-13 to 158°F)
<b>Humidity</b>	IEC 68-2-3: Damp Heat 90% RH (non-condensing at 40°C (104°F))

## Ordering Information

**Type 2706** Power Amplifier includes the following accessories:

	Mains Cable
JP 0101	Standard Coaxial Plug
3×VF 0010	2 A, 250 V Fuse, time-lag
2×VF 0013	1 A, 250 V Fuse, time-lag

Brüel&Kjær reserves the right to change specifications and accessories without notice



**WORLD HEADQUARTERS:**

DK-2850 Naerum · Denmark · Telephone: +45 45 80 05 00 · Fax: +45 45 80 14 05 · Internet: <http://www.bk.dk> · e-mail: [info@bk.dk](mailto:info@bk.dk)

Australia (02 ) 9450-2066 · Austria 00 43-1-865 74 00 · Belgium 016/44 92 25 · Brazil (011) 246-8166 · Canada: (514) 695-8225 · China 10 6841 9625 / 10 6843 7426

Czech Republic 02-67 021100 · Finland 90-229 3021 · France (01) 69 90 69 00 · Germany 0610 3/908-5 · Holland (0)30 6039994 · Hong Kong 254 8 7486

Hungary (1) 215 83 05 · Italy (02) 57 60 4141 · Japan 03-3779-8671 · Republic of Korea (02) 3473-0605 · Norway 66 90 4410 · Poland (0-22) 40 93 92 · Portugal (1) 47114 53

Singapore (65) 275-8816 · Slovak Republic 07-37 6181 · Spain (91) 36810 00 · Sweden (08) 71127 30 · Switzerland 01/94 0 09 09 · Taiwan (02) 713 9303

United Kingdom and Ireland (0181) 954-236 6 · USA 1 - 800 - 332 - 2040

Local representatives and service organisations worldwide