

2520

Pulsed Laser Diode Test System



- Simplifies laser diode LIV testing prior to packaging or active temperature control
- Integrated solution for in-process LIV production testing of laser diodes at the chip or bar level
- Sweep can be programmed to stop on optical power limit
- Combines high accuracy source and measure capabilities for pulsed and DC testing
- Synchronized DSP based measurement channels ensure highly accurate light intensity and voltage measurements
- Programmable pulse on time from 500ns to 5ms up to 4% duty cycle
- Pulse capability up to 5A, DC capability up to 1A
- 14-bit measurement accuracy on three measurement channels (V_{fr} front photodiode, back photodiode)
- Measurement algorithm increases the pulse measurement's signal-to-noise ratio
- Up to 1000-point sweep stored in buffer memory eliminates GPIB traffic during test, increasing throughput
- Digital I/O binning and handling operations
- IEEE-488 and RS-232 interfaces



Remote Electrical Test Head included

recently, these producers were forced to use relatively slow and cumbersome test stands for testing laser diodes at the chip and bar level, which often led to production bottlenecks.

Higher Resolution for Higher Yields

To achieve the required signal-to-noise ratio, traditional chip- and bar-level LIV testing solutions have required the use of boxcar averagers or test system control software modifications to allow averaging several pulsed measurements. The resolution of these measurements is critical for the "kink" test and threshold current calculations. With earlier test system designs, particularly when performing the kink test, low resolution and poor linearity of the analog digitizer made it extremely difficult to discriminate between noise in the measurement and an actual device kink. The Model 2520's unique DSP-based measurement approach automatically

The Model 2520 Pulsed Laser Diode Test System is an integrated, synchronized system for testing laser diodes early in the manufacturing process, when proper temperature control cannot be easily achieved. The Model 2520 provides all sourcing and measurement capabilities needed for pulsed and continuous LIV (light-current-voltage) testing of laser diodes in one compact, half-rack instrument. The tight synchronization of source and measure capabilities ensures high measurement accuracy, even when testing with pulse widths as short as 500ns.

LIV Test Capability

The Model 2520 can perform pulsed LIV testing up to 5A and continuous LIV testing up to 1A. Its pulsed testing capability makes it suitable for testing a broad range of laser diodes, including the pump laser designs for Raman amplifiers. The instrument's ability to perform both DC and pulsed LIV sweeps on the same device simplifies analyzing the impact of thermal transients on the LIV characteristics of the laser diode.

Maximize Throughput and Eliminate Production Bottlenecks

By working in cooperation with leading laser diode manufacturers, Keithley designed the Model 2520 specifically to enhance chip- and bar-level test stand yield and throughput. Its integrated design, ease of use, high speed, and high accuracy provides a complete solution to help laser diode manufacturers meet their production schedules. Producers of laser diodes face constant pressure to increase test throughput and optimize return on investment for their capital equipment used in production testing. Until

APPLICATIONS

Production testing of:

- Telecommunication laser diodes
- Optical storage read/write head laser diodes
- Vertical Cavity Surface-Emitting Lasers (VCSELs)
- Thermal impedance
- Junction temperature response

Multi-channel pulsed test of laser diodes

OPTOELECTRONICS TEST

1.888.KEITHLEY (U.S. only)

www.keithley.com

KEITHLEY

A GREATER MEASURE OF CONFIDENCE

2520**Ordering Information****2520 Pulsed Laser Diode Test System with Remote Test Head****2520/KIT1****Pulsed Laser Diode Measurement Kit (includes 2520, 2520INT, and 3 ft. triax cable)****Accessories Supplied****User's Manual, Quick Reference Guide, Triax Cables (2), BNC 10Ω Coaxial Cables (4)****ACCESSORIES AVAILABLE**

2520INT-1-GE	Integrating Sphere (1 inch) with Germanium Detector
7007-1	Double Shielded GPIB Cable, 1m (3.3 ft.)
7007-2	Double Shielded GPIB Cable, 2m (6.6 ft.)
KPCI-488LPA	IEEE-488 Interface/Controller for the PCI Bus
KUSB-488B	IEEE-488 USB-to-GPIB Adapter for USB Port

SERVICES AVAILABLE

2520-3Y-EW	1-year factory warranty extended to 3 years from date of shipment
C/2520-3Y-DATA 3 (Z540-1 compliant)	calibrations within 3 years of purchase*

*Not available in all countries

Pulsed Laser Diode Test System

identifies the settled region of the pulsed waveforms measured. This means the Model 2520 stores only that portion of the pulse that is "flat" and contains meaningful data. All measurements made in the flat portion of the pulse are averaged to improve the Signal-to-Noise ratio still further. If greater resolution is required, the Model 2520 can be programmed to perform several pulse and measure cycles at the same pulse amplitude. By making it possible to conduct more thorough testing at the bar or chip level, the Model 2520 also eliminates the wasted time and costs associated with assembling then scrapping modules with non-compliant diodes.

Simple, One-Box Test Solution

The Model 2520 offers three channels of source and measurement circuitry. All three channels are controlled by a single digital signal processor (DSP), which ensures tight synchronization of the sourcing and measuring functions. The laser diode drive channel provides a current source coupled with voltage measurement capability. Each of the two photodetector channels supplies an adjustable voltage bias and voltage compliance, in addition to current measurement capability. These three channels provide all the source and measure capabilities needed for full LIV characterization of laser diodes prior to integration into temperature controlled modules. By eliminating the need for GPIB commands to perform test sweeps with multiple separate instruments, the Model 2520's integrated sourcing and measurement allows a significant improvement in throughput.

Remote Test Head Maximizes Signal-to-Noise Ratio

The mainframe and remote test head architecture of the Model 2520 is designed to enhance pulsed measurement accuracy, even at the sub-microsecond level. The remote test head ensures the measurement circuitry is located near the DUT, mounted on the fixture, minimizing cable effects. As the schematic in **Figure 1** shows, traditional semi-custom systems typically employed in the past require significant integration. The architecture of the Model 2520 (**Figure 2**) offers a far more compact and ready-to-use solution.

High Speed Pulse and Measure to Minimize Thermal Effects

The Model 2520 can accurately source and measure pulses as short as 500 nanoseconds to minimize unwanted thermal effects during LIV testing. Users can program the pulse width from 500ns to 5ms and pulse off time from 20μs to 500ms. There is a software duty cycle limit of 4% for currents higher than 1A. To ensure greater accuracy, the instrument provides pulse width programming resolution levels of 10μs (off time) and 100ns (on time).

Prior to the introduction of the Model 2520, test instrument limitations often placed barriers on test performance. However, with the Model 2520, the limiting factor is not the test instrument, but the

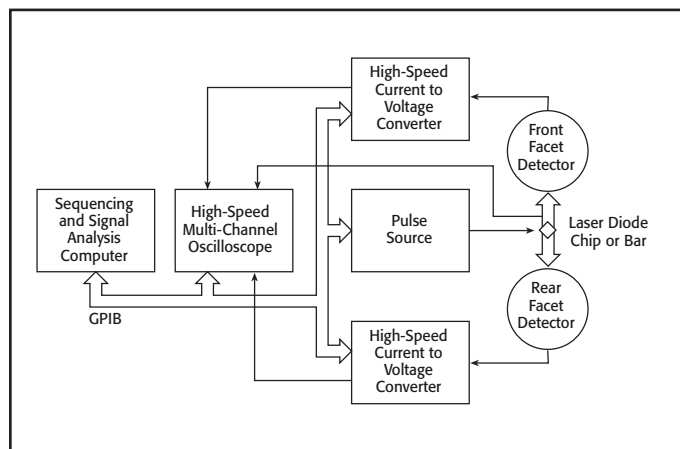

Figure 1. This schematic reflects the current testing practices of major laser diode manufacturers. Note that the use of discrete test components increases the integration and programming effort, while severely limiting the flexibility of the test system.

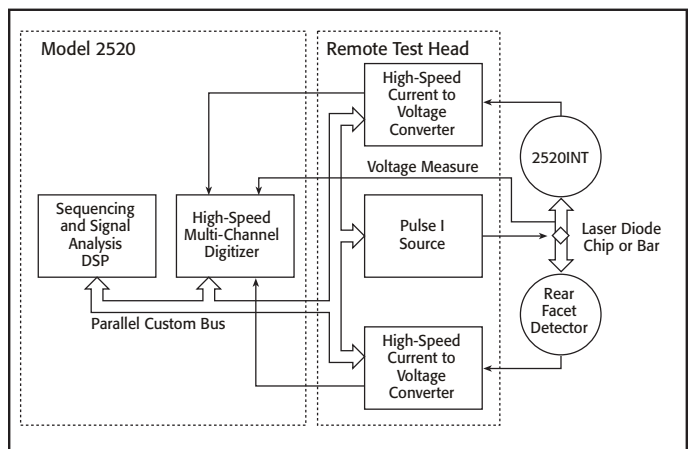

Figure 2. The Model 2520 integrates synchronization, source, and measure capabilities in a single half-rack instrument (with remote test head) to provide maximum flexibility and test throughput.

1.888.KEITHLEY (U.S. only)**www.keithley.com****KEITHLEY**

A GREATER MEASURE OF CONFIDENCE

physics of the connections to the device. Keithley's optoelectronics applications engineers have addressed these issues by studying and documenting the optimum cable configuration to enhance measurement accuracy with extremely fast pulses. **Figure 3** illustrates the results of a typical pulse LIV sweep test with the Model 2520. In this test, a 100-point pulsed LIV sweep using a $1\mu\text{s}$ pulse width, at 1% duty cycle, was completed in just 110ms (including data transfer time), several orders of magnitude faster than existing, semi-custom test systems.

ESD Protection

A laser diode's material make-up, design, and small size make it extremely sensitive to temperature increases and electrostatic discharges (ESDs). To prevent damage, prior to the start of the test and after test completion, the Model 2520 shorts the DUT to prevent transients from destroying the device. The instrument's 500 nanosecond pulse and measure test cycle minimizes device heating during test, especially when a short duty cycle is used.

Test Sequencing and Optimization

Up to five user-definable test setups can be stored in the Model 2520 for easy recall. The Model 2520's built-in Buffer Memory and Trigger Link interface can reduce or even eliminate time-consuming GPIB traffic during a test sequence. The Buffer Memory can store up to 1000 points of measurement data during the test sweep. The Trigger Link combines six independent software selectable trigger lines on a single connector for simple, direct control over all instruments in a system. This interface allows the Model 2520 to operate autonomously following an input trigger. The Model 2520 can be programmed to output a trigger to a compatible OSA or wavelength meter several nanoseconds prior to outputting a programmed drive current value to initiate spectral measurements.

Accessories and Options

The Model 2520 comes with all the interconnecting cables required for the main instrument and the remote test head. Production test practices vary widely (automated vs. semi-automated vs. manual), so the cable assemblies from the remote test head to the DUT can vary significantly. To accommodate these differing requirements, Keithley has developed the Model 2520 RTH to DUT Cable Configuration Guide to help customers determine the proper cable assemblies to use to connect the remote test head (RTH) to the DUT.

Interface Options

The Model 2520 provides standard IEEE-488 and RS-232 interfaces to speed and simplify system integration and control. A built-in digital I/O interface can be used to simplify external handler control and binning operations.

Additional LIV Test Solutions

For production testing laser diodes after they have been packaged in temperature controlled modules, Keithley offers the Laser Diode LIV Test System with increased 28-bit core measurement resolution, allowing for more detailed characterization. This flexible system combines all the DC measurement capabilities required to test these modules with tight temperature control over the DUT in a modular instrument package. Configured from proven Keithley instrumentation, the basic configuration can be easily modified to add new measurement functions as new testing needs evolve.

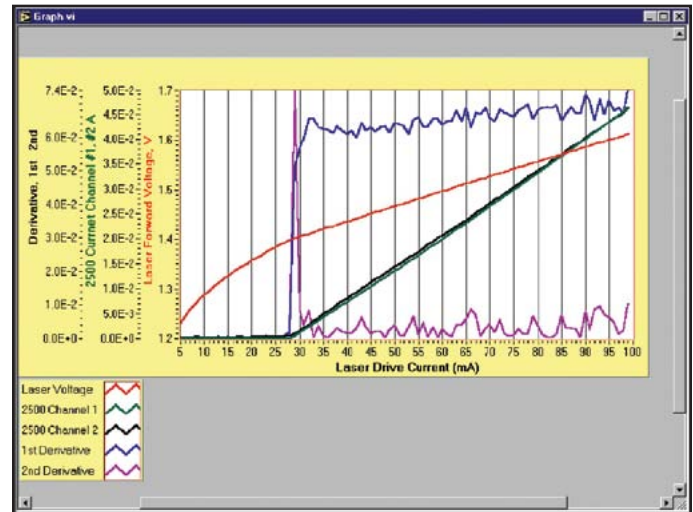

Figure 3. This plot illustrates the Model 2520's pulsed LIV sweep capability. The sweep was programmed from 0 to 100mA in 1mA steps. Pulse width was programmed at $1\mu\text{s}$ at 1% duty cycle, providing for a complete sweep in just 10ms (excluding data transfer time).



Figure 4. Model 2520 Remote Test Head

LASER DIODE PULSE OR DC CURRENT SOURCE SPECIFICATIONS

DRIVE CURRENT					OFF CURRENT ⁴			
Source Range	Programming Resolution	Approx. Electrical Resolution	Accuracy ^{1, 6} ±(%rdg. + mA) ^{2, 3}	RMS Noise (typical) (1kHz–20MHz)	Range	Programming Resolution	Approx. Electrical Resolution	Accuracy ¹ ±(%rdg. + mA)
0–500 mA	10 μA	8 μA	0.2 + 0.45	70 μA	0–15 mA	1 μA	7 nA typ.	0.2 + 0.45
0–1.0 A DC 0–5.0 A Pulse	100 μA	80 μA	0.2 + 4.5	800 μA	0–150 mA	10 μA	70 nA typ.	0.2 + 4.5

TEMPERATURE COEFFICIENT (0°–18°C & 28°–50°C): ±(0.15 × accuracy specification)/°C.

PULSE ON TIME¹⁹: 500ns to 5ms, 100ns programming resolution.

PULSE OFF TIME¹⁹: 20μs to 500ms, 10μs programming resolution.

PULSE DUTY CYCLE^{19, 20, 21}: 0 to 99.6% for ≤1.0A; 0 to 4% for >1.0A.

VOLTAGE COMPLIANCE: 3V to 10V, 10mV programming resolution⁵.

POLARITY: 1 quadrant source, polarity reversal available through internal relay inversion.

OUTPUT OFF: <200mΩ short across laser diode; measured at Remote Test Head connector.

LASER DIODE VOLTAGE MEASURE SPECIFICATIONS

Range	Minimum Resolution	Accuracy ±(%rdg. + volts) ^{1, 12}	RMS Noise (typical) ¹³
5.00 V	0.33 mV	0.3% + 6.5 mV	60 μV
10.00 V	0.66 mV	0.3% + 8 mV	120 μV

TEMPERATURE COEFFICIENT (0°–18°C & 28°–50°C): ±(0.15 × accuracy specification)/°C.

MAX. LEAD RESOLUTION: 100Ω for rated accuracy.

INPUT IMPEDANCE: 2MΩ differential, 1MΩ from each input to common.

Input bias current ±7.5μA max.

PHOTODIODE VOLTAGE BIAS SOURCE SPECIFICATIONS (each channel)

RANGE: 0 to ±20VDC.

PROGRAMMING RESOLUTION: 10mV.

ACCURACY: ±(1% + 50mV).

CURRENT: 160mA max. with V-Bias shorted to I-Measure.

RMS NOISE (1kHz to 5MHz): 1mV typical.

PHOTODIODE CURRENT MEASURE SPECIFICATIONS (each channel)

Range	Minimum Resolution ⁴	DC Input Impedance	Accuracy ±(%rdg. + current) ^{1, 2}	RMS Noise (typical) ³
10.00 mA	0.7 μA	< 10 Ω	0.3% + 20 μA	90 nA
20.00 mA	1.4 μA	< 6 Ω	0.3% + 65 μA	180 nA
50.00 mA	3.4 μA	< 3 Ω	0.3% + 90 μA	420 nA
100.00 mA	6.8 μA	<2.5 Ω	0.3% + 175 μA	840 nA

TEMPERATURE COEFFICIENT (0°–18°C & 28°–50°C): ±(0.15 × accuracy specification)/°C.

INPUT PROTECTION: The input is protected against shorting to the associated channel's internal bias supply. The input is protected for shorts to external supplies up to 20V for up to 1 second with no damage, although calibration may be affected.

SYSTEM SPEEDS

READING RATES (ms)^{15, 16}

Number of Source Points ¹⁷	To Memory	To GPIB
1	5.3	6.8
10 ¹⁸	9.5	18
100 ¹⁸	48	120
1000 ¹⁸	431	1170

Setting and Range	Load ⁷	Pulse Mode	Pulse Overshoot Max. ^{6, 8, 9}	Rise/Fall Time ^{6, 8, 9, 10}	
				Typical	Max.
500 mA	10 Ω ¼ Watt	Fast	1.0%	55 ns	80 ns
500 mA	10 Ω ¼ Watt	Slow	0.1%	1 μs	1.3 μs
5.00 A	1.5 Ω 1 Watt	Fast	1.0%	100 ns	130 ns
5.00 A	1.5 Ω 1 Watt	Slow	0.1%	1 μs	1.3 μs

GENERAL

DC FLOATING VOLTAGE: User may float common ground up to ±10VDC from chassis ground.

COMMON MODE ISOLATION: >10⁹Ω.

OVERRANGE: 105% of range on all measurements and voltage compliance.

SOURCE OUTPUT MODES:

- Fixed DC Level
- Fixed Pulse Level
- DC Sweep (linear, log, and list)
- Pulse Sweep (linear, log, and list)
- Continuous Pulse (continuous – low jitter)

PROGRAMMABILITY: IEEE-488 (SCPI-1995.0), RS-232, 5 user-definable power-up states plus factory default and *RST.

DIGITAL INTERFACE:

Safety Interlock: External mechanical contact connector and removable key switch.

Aux. Supply: +5V @ 300mA supply.

Digital I/O: 2 trigger input, 4 TTL/Relay Drive outputs (33V @ 500mA max., diode clamped).

Trigger Link: 6 programmable trigger input/outputs.

Pulse Trigger Out BNC: +5V, 50Ω output impedance, output trigger corresponding to current source pulse; pulse to trigger delay <100ns. See Figure 3.

MAINS INPUT: 100V to 240V rms, 50–60Hz, 140VA.

EMC: Conforms to European Union Directive 89/336/EEC (EN61326-1).

SAFETY: Conforms to European Union Directive 73/23/EEC (EN61010-1) CAT 1.

VIBRATION: MIL-PRF-28800F Class 3, Random.

WARM-UP: 1 hour to rated accuracy.

DIMENSIONS, WEIGHT:

Main Chassis, bench configuration (with handle & feet): 105mm high × 238mm wide × 416mm deep (4½ in. × 9½ in. × 16½ in.). 2.67kg (5.90 lbs).

Remote Test Head: 95mm high × 178mm deep (with interlock key installed) × 216mm wide (3½ in. × 7 in. × 8½ in.). 1.23kg (2.70 lbs).

ENVIRONMENT:

Operating: 0°–50°C, 70% R.H. up to 35°C. Derate 3% R.H./°C, 35°–50°C.

Storage: –25° to 65°C.

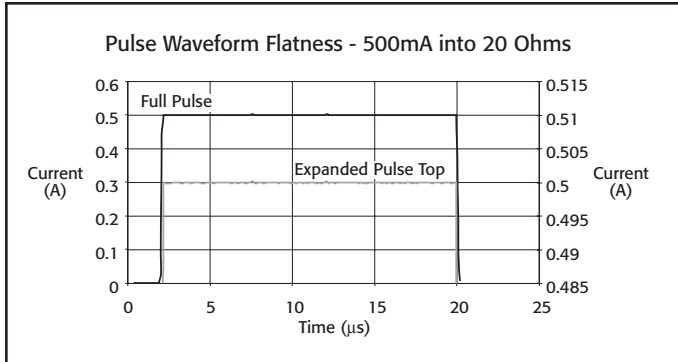

Figure 1

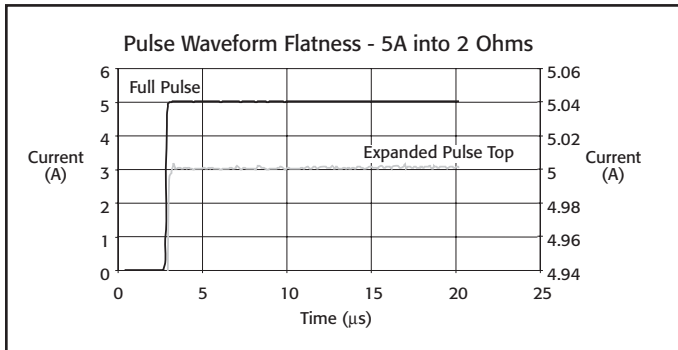

Figure 2

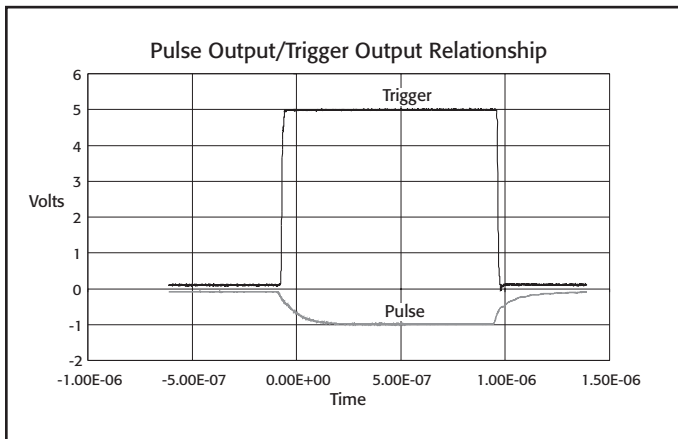

Figure 3

NOTES

1. 1 year, 23°C ±5°C.
2. If $\sqrt{\text{Duty Cycle}} \cdot I$ exceeds 0.2, accuracy specifications must be derated with an additional error term as follows:
 500mA Range: $\pm 0.1\% \text{ rdg.} \cdot \sqrt{D} \cdot I$
 5A Range: $\pm 0.3\% \text{ rdg.} \cdot \sqrt{D} \cdot I$
 where: I = current setting
 D = duty cycle
 This derating must also be applied for a period equal to the time that $\sqrt{D} \cdot I$ was ≥ 0.2 .
3. Not including overshoot and setting time.
4. Pulse mode only.
5. Output: 500mA DC on 500mA range and 1A DC on 5A range.
6. Refer to Model 2520 Service Manual for test setup of current accuracy.
7. Figures 1 and 2 are typical pulse outputs into resistive loads.
8. Typical.
9. Per ANSI/IEEE Std 181-1977.
10. Per ANSI/IEEE Std 181-1977 10% to 90%.
11. DC accuracy $\pm 700\text{mV}$ @ output terminal. 0.2Ω typical output impedance.
12. At DC, 10µs measurement pulse width, filter off.
13. Standard deviation of 10,000 readings with 10µs pulse width, filter off, with I source set to 0A DC.
14. The A/D converter has 14 bit resolution. The useful resolution is improved by reading averaging. The useful resolution is:

$$\text{Useful Resolution} = \frac{\text{Range}}{2^{14}} \cdot \frac{1}{\sqrt{\frac{\text{Pulse Width (ns)} - 400\text{ns}}{100\text{ns}} \cdot \text{Averaging Filter Setting}}}$$
15. Excluding total programmed (Pulse ON time + Pulse OFF time).
16. Front panel off, calc off, filter off, duty cycle <10%, binary communications.
17. Returning 1 voltage and 2 current measurements for each source point.
18. Sweep mode.
19. Valid for both continuous pulse and sweep modes.
20. Shown is the Power Distribution % based on current settings.
21. Timing Cycle ($P\%/(pw + pd)$): 4% max.