

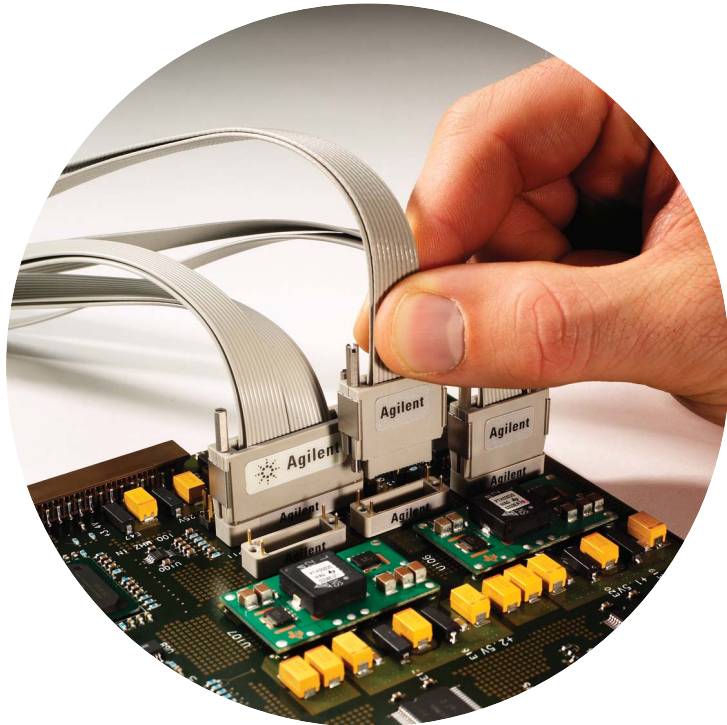

Probing Solutions for Logic Analyzers

Data Sheet

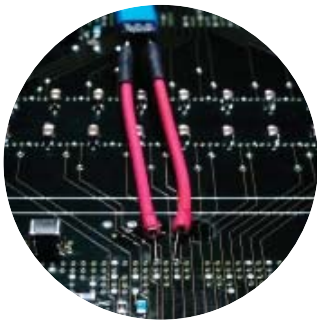

Bring the full power of your Agilent logic analyzer to your project with high quality probing solutions

- Wide range of solutions to meet your measurement needs
- Soft Touch Connectorless probing
- High-density, high-performance probing solutions
- General-purpose probing



Agilent Technologies

Table of Contents

| | |
|---|------------|
| Reliable Connections Ensure Accuracy | 3 |
| Which Logic Analyzer? | 3 |
| Probe Selection Guide for All Agilent Logic Analyzers | 4 |
| Selecting the Optimum Probing Strategy | 7 |
| Probing Solutions for 40-pin Logic Analyzers | 9 |
| General-Purpose Probing | 9 |
| Designing for Logic Analysis Probing | 11 |
| Soft Touch Connectorless Probing | 12 |
| Mictor and Samtec Probing | 23 |
| Custom Probing | 31 |
| Probing Solutions for 90-pin Logic Analyzers | 36 |
| General-Purpose Probing | 36 |
| Soft Touch Connectorless Probing | 42 |
| Mictor and Samtec Probing | 59 |
| High-Speed Timing Probing | 62 |
| General-Purpose Probing Flying Lead Probing Accessories | 63 |
| 40-pin and 90-pin Logic Analyzers Probe Cables | 64 |
| Related Information | 65 |
| Agilent Advantage Services | Back cover |
| Contact Agilent | Back cover |

Reliable Connections Ensure Accuracy

- **Impedance**

High input impedance ensures minimum intrusion on your circuit. Although many probes might be acceptable for lower frequencies, capacitive loading becomes significant at higher frequencies. The Agilent probing products perform over a wide frequency spectrum.

- **Ruggedness**

Probes with quality mechanical design provide solid electrical connections. Intermittent open circuits would only add one more variable to your debugging equation. Agilent probes are mechanically designed to relieve strain and ensure rugged, reliable connection.

- **Immunity to Noise**

Electromagnetic noise can corrupt data captured by the logic analyzer. Agilent probing solutions are designed for a high immunity to transient noise.

- **Performance**

Agilent logic analyzers have front-end circuitry that supports the state and timing specifications of the analyzer. This circuitry, together with the Agilent probing solutions described in this document, will accurately capture the target signals at the specified clock rates.

Other Considerations

Physical connection compatibility between various Agilent probes may allow you to mix and match a variety of probes and accessories. However, a probe accessory designed for slower clock speeds will not deliver high-speed target performance simply because it is used with a higher speed analyzer module. Also, the serial connection of multiple probe leads and/or accessories will degrade signal integrity.

Signal Frequency Content Drives Probing Solutions

Faster clock rates demand tighter timing tolerances, such as setup and hold specifications. Systems with faster clock rates usually have shorter rise and fall times. Signals with shorter transition times have more high frequency content and are more susceptible to high frequency analog problems such as cross talk, reflections, ground bounce, noise and emissions. Susceptibility of a system to analog problems relates to the transition times of the signals, not the clock rate. A system with slow transition times cannot have high clock rates. However, it is possible for a system with slower clock rates to have signals with very fast transition times.

General-purpose probing solutions provide the analog bandwidth required to run each logic analyzer module at its maximum clock rate. The high input impedance of these probes, especially at high frequencies, presents a minimal load to most systems. Systems that are operating with little margin should be designed with consideration for both the system components and the input impedance of the probing solution being used during debug. Input impedance specifications or equivalent load diagrams can be found for each of the probing solutions described in this document.

Which Logic Analyzer?

Agilent logic analyzers have two methods of connection to the probes. One uses a 3M-style connector with two rows of 20 pins on 0.1-inch centers, as illustrated in Figure 1.1. Probes for these analyzers are identified in this document as “for analyzers with 40-pin pod connectors.”

The other style uses a 90-pin, high-density connector, as illustrated in Figure 1.2. Probes for these analyzers are identified in this document as “for analyzers with 90-pin pod connectors.”

Currently available Agilent logic analyzers in these two groups are as follows:

40-pin pod connector (pages 9 – 35)

16911A

16910A

16800 Series benchtop analyzers

90-pin pod connector (pages 36 – 62)

16950B, 16951B

16962A and U4154A

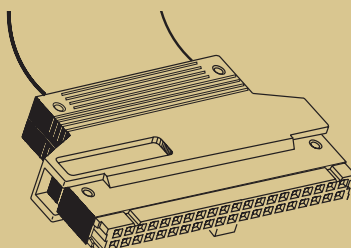

Figure 1.1. 40-pin pod connector

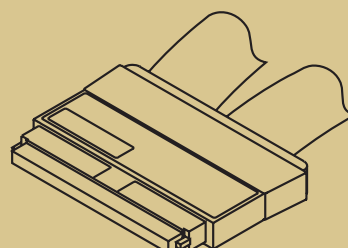

Figure 1.2. 90-pin pod connector

Probe Selection Guide for All Agilent Logic Analyzers

Compatible with Agilent models 16910A/11A, 16800 Series, 16750/51/52A/B, 1674X Series, 1671x Series, 165xx Series modules, 1690 Series, 1680 Series, 1670 Series, 1660 Series, 1650 Series, and E9340 logic analyzers



| | Soft touch connectorless probes Supplied with five retention modules | | | Samtec probe | Mictor probe | General purpose flying lead set |
|-----------------------------|---|---|---|---|---|---|
| Model number | E5396A | E5404A | E5394A | E5385A | E5346A | E5383A |
| Application | Quick connection to many channels in a small footprint without a header designed into the target system | | | Quick connection to many signals in a small footprint | Quick connection to many signals in a small footprint | Flexible connection to individual signals |
| Number of channels | 17 16 data, 1 clock | 34 32 data, 2 clock | 34 32 data, 2 clock | 34 32 data, 2 clock | 34 32 data, 2 clock | 17 16 data, 1 clock |
| Supported signal types | All probes: single-ended clock, single-ended data | | | | | |
| Maximum data rate | > 2.5 Gb/s | > 2.5 Gb/s | > 2.5 Gb/s | 1.5 Gb/s | Equivalent to the logic analyzer data rate the probe is attached to | Equivalent to the logic analyzer data rate the probe is attached to |
| Minimum signal amplitude | 500 mV p-p | 500 mV p-p | 500 mV p-p | 500 mV p-p | 500 mV p-p ¹ | 600 mV p-p |
| Connection to target system | Requires half-size soft touch footprint designed into the target | Requires Pro Series soft touch footprint designed into the target | Requires original soft touch footprint designed into the target | Requires 100-pin Samtec connector designed into the target system | Requires 38-pin Mictor connector designed into the target system ² | Compatible with a wide assortment of accessories to connect to individual leads |
| Input capacitance | < 0.7 pF | < 0.7 pF | < 0.7 pF | 1.5 pF | 3.0 pF | 1.5 pF |
| Additional supplies | Additional five retention modules | Additional five retention modules | Additional five retention modules | See Table 1 page 29 for pc board connectors and shrouds | See Table 1 page 29 for pc board connectors and shrouds | See Figure 2.3 page 9 for additional leads and grabbers |
| Orderable as | Order kit E5396-68702 | Order kit E5403A | Order kit E5387-68701 | | | |

1. Model E5339A low voltage Mictor probe = 250 mV p-p

2. Model E5351A unterminated Mictor probe requires isolation networks to be provided on the target system. See page 27 for details.

Probe Selection Guide for All Agilent Logic Analyzers

Compatible with Agilent logic analyzers U4154A, 16962A, 16951B, 16950A/B, 16760A, 16756A, 16755A, 16754A, and 16753A



Soft touch connectorless probes

All soft touch probes are supplied with 5 retention modules

| | E5406A | | | | |
|---------------------------------------|--|---|---|--|--|
| Model number | E5398A | E5402A * | E5390A | E5405A | E5387A |
| Application | Quick connection to many channels in a small footprint without a header designed into the target | | | | |
| Number of channels | 17 16 data, 1 clock | 34 32 data, 2 clocks | 34 32 data, 2 clocks | 17 16 data, 1 clock | 17 16 data, 1 clock |
| Supported signal types | Differential or single-ended clock single-ended data | | | Differential or single-ended clock and or data | |
| Maximum data rate | > 2.5 Gb/s | > 2.5 Gb/s | > 2.5 Gb/s | > 2.5 Gb/s | > 2.5 Gb/s |
| Minimum signal amplitude | 250 mV _{p-p} | 250 mV _{p-p} | 250 mV _{p-p} | $V_{max} - V_{min}$ 200 mV | $V_{max} - V_{min}$ 200 mV |
| Connection to target system | Requires half-size soft touch footprint designed into the target | Requires Pro Series soft touch footprint designed into the target | Requires original soft touch footprint designed into the target | Requires Pro Series soft touch footprint designed into the target system | Requires original soft touch footprint designed into the target system |
| Input capacitance | < 0.7 pF | < 0.7 pF | < 0.7 pF | < 0.7 pF | < 0.7 pF |
| Kit of 5 additional retention modules | E5396-68702 | E5403A | E5387-68701 | E5403A | E5387-68701 |

* The E5402A Soft Touch Pro probe is a low profile right angle version of the E5406A above

Probe Selection Guide for All Agilent Logic Analyzers

Compatible with Agilent logic analyzers U4154A, 16962A, 16951B, 16950A/B, 16760A, 16756A, 16755A, 16754A, and 16753A





| | Samtec probes | | Mictor probes | General purpose flying lead sets | |
|-----------------------------|---|---|--|---|---|
| Model number | E5378A | E5379A | E5380A | E5382A | E5381A |
| Application | Quick connection to many channels in a small footprint | | | Flexible connection to many signals | |
| Number of channels | 34 32 data, 2 clocks | 17 16 data, 1 clock | 34 32 data, 2 clocks | 17 16 data, 1 clock | 17 16 data, 1 clock |
| Supported signal types | Differential or single-ended clock single-ended data | Differential or single-ended clock and or data | Single-ended clock single-ended data | Differential or single-ended clock single-ended data | Differential or single-ended clock and or data |
| Maximum data rate | 1.5 Gb/s | 1.5 Gb/s | 600 Mb/s | 1.5 Gb/s | 1.5 Gb/s |
| Minimum signal amplitude | 250 mV _{p-p} | $V_{max} - V_{min}$ 200 mV | 300 mV _{p-p} | 250 mV _{p-p} | $V_{max} - V_{min}$ 200 mV |
| Connection to target system | Requires 100-pin Samtec connector designed into the target system | Requires 100-pin Samtec connector designed into the target system | Requires 38-pin Mictor connector designed into the target system | Compatible with a wide assortment of accessories to connect to individual leads | Compatible with a wide assortment of accessories to connect to individual leads |
| Input capacitance | 1.5 pF | 1.5 pF | 3.0 pF | 1.3 pF | 0.9 pF |
| Additional supplies | See Table 8 page 60 for shrouds and pc board connectors | | | See Table 5 page 36 | See Figure 5.4 page 39 |

Note: E5386A half-channel transition adapter provides transition between probes and 16760A logic analyzer cables. Use to reduce the number of probes and connectors required to run in half channel mode. Adapter maps to even channels to all pins of an E5387A, E5379A, E5387A, E5390A, E5405A, or E5406A.



Selecting the Optimum Probing Strategy

What is the best way to probe your signals, given their unique characteristics?

| Available probing options for all Agilent logic analyzers | | |
|---|--|---|
| | Connectorless | Connector Samtec |
| |  |  |
| Connection to the target system | Requires appropriate pro series soft touch or original soft touch footprint designed into the target system. Retention module is used for alignment and mechanical retention only. | Requires 100-pin Samtec connector designed into the target system |
| Advantages | <ul style="list-style-type: none"> • Reduces cost and shortens the design cycle by eliminating a connector • Eliminates the capacitive loading of a connector, which gives you the lowest-loading (less than 0.7 pF), highest-performance (> 2.5 Gbits/s rate) logic analyzer probing option available • Pliable micro spring-pin design with four-point crown tip allows you to easily attach and get a reliable, repeatable contact even for contaminated or uneven board surfaces • Flow through signal routing streamlines design flow and maintains differential pair spacing to ensure constant differential-mode impedance and virtually eliminate stubs • Acquire high-speed single-ended or differential signals without impacting the performance of your circuit, while providing an accurate representation to the logic analyzer • Provides ability to attach retention module to probe and browse multiple signals by pressing the probe against the target device • Compatible with all board finishes, including lead free | <ul style="list-style-type: none"> • High-performance connector solution (1.5 pF loading, 1.5 Gb/s data rate) • Supports single-ended and differential signals • 3 times the performance and half the loading of Mictor solution |
| Disadvantages | <ul style="list-style-type: none"> • Requires up-front design of probe footprint on PCB | <ul style="list-style-type: none"> • Added cost to include connector • Requires up-front design of connector on PCB |

Selecting the Optimum Probing Strategy

What is the best way to probe your signals, given their unique characteristics?

| Available probing options for all Agilent logic analyzers | | |
|---|---|--|
| | Connector Mictor | Flying leads |
| |  |  |
| Connection to the target system | Requires 38-pin Mictor connector designed into the target system | Connects to individual, widely dispersed signals at IC pins, traces, pads, vias |
| Advantages | <ul style="list-style-type: none"> Reliable and cost-effective solution for lower data rates (600 Mb/s) Supports single-ended signaling 3.0 pF capacitive loading | <ul style="list-style-type: none"> High-performance accessories are based on award winning, InfiniiMax scope probes Compatible with a wide variety of accessories to connect to IC pins, traces, pads, vias Maintains a one-to-one signal-to-ground ratio Doesn't require up-front design effort |
| Disadvantages | <ul style="list-style-type: none"> Added cost to include connector Combination of through-hole and surface-mount technology can make signal routing and board component loading difficult Requires up-front design of connector on PCB | <ul style="list-style-type: none"> More time-consuming to connect |

Probing Solutions for 40-pin Logic Analyzers

General-Purpose Probing

E5383A 17-channel single-ended flying lead probe

Ideal when only a few lines may need to be probed or probe points are distributed across a target. The E5383A includes a set of 20 IC test clips and five ground leads.

Logic analysis general-purpose probes

General-purpose probing requires connecting probe leads to individual signal lines. This method is most convenient for a small to moderate number of signals, very flexible, and can be used in conjunction with other probing methods.

Note: Any probed signal line must be able to supply a minimum of 600 mV to the probe with the specified loading.

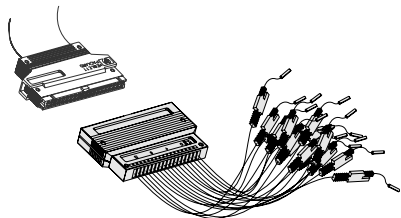

Figure 2.2. E5383A 17-channel probe lead set

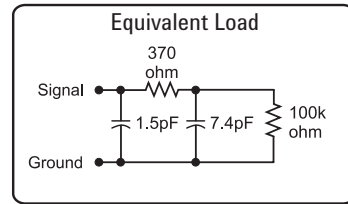
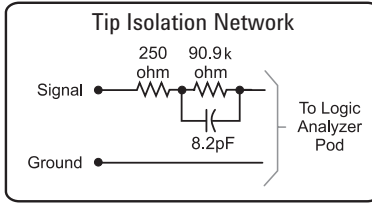

Figure 2.1. Probe tip Isolation network and equivalent load

The standard probing system

The standard probing system consists of IC clips, probe leads, probe housing and probe cable. Because it is passive, the standard probing system is smaller, lighter, and much easier to use than active probing systems. This passive probing system is similar to a probing system used on a high frequency oscilloscope. It consists of an isolation network (as shown in Figure 2.1) at the probe tip and a shielded resistive transmission line. The advantages of this system are:

- High input impedance. See Figure 2.1.
- Signal ground at the probe tip for high-speed signals.
- Inexpensive, removable probe tip assemblies.

Probe leads and lead sets

Probe leads are configured into lead sets, which can probe 16 data channels with ground, one clock channel, and a common ground. A 17-channel probe lead set (E5383A) is shown in Figure 2.2, along with the replacement part numbers for individual components in Figure 2.3.

Each probe lead is a 12-inch, twisted-pair cable connected to the probe housing (see Figure 2.3). The probe tip includes a signal lead, a connector for a ground lead, and the isolation network.

The signal and ground leads can be connected directly to the target system. This requires installing 0.63 mm (0.025 inch) square pins, or round pins with a diameter of between 0.66 mm (0.026 inch) and 0.84 mm (0.033 inch) directly on the board. An IC test clip can also be used. The same specifications apply for the pin dimensions of the test clip. (See Figure 2.6 for IC test clips available from commercial sources.)

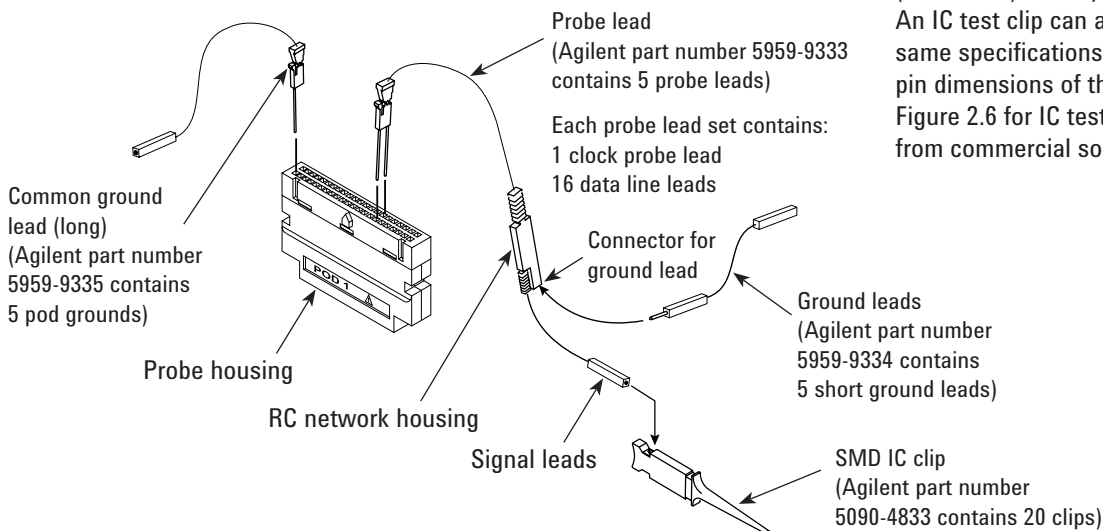

Figure 2.3. E5383A 17-channel probe lead set replacement parts

Probing Solutions for 40-pin Logic Analyzers

General-Purpose Probing

IC clips

The surface-mount device IC clip with twin hooks (part number 5090-4833, containing 20 IC clips) is designed for fine surface-mounted component leads. The twin hook 0.5 mm IC clip (part number 10467-68701, containing four 0.5 mm IC clips), is very useful for 0.5 mm pitch components. See Figure 2.5.

Grounding

There are three methods of grounding the probe system. First, the entire probe lead set can be grounded through the common ground. This requires only one connection, but is not recommended because it will cause poor signal fidelity in systems with fast transition times. The recommended method is to individually ground each probe lead. This yields optimal signal fidelity and is required for signals with faster transition times (< 4 - 5 ns).

For moderate rise times (greater than 2 ns), it may be acceptable to ground every other (or every fourth) ground connection to the target.

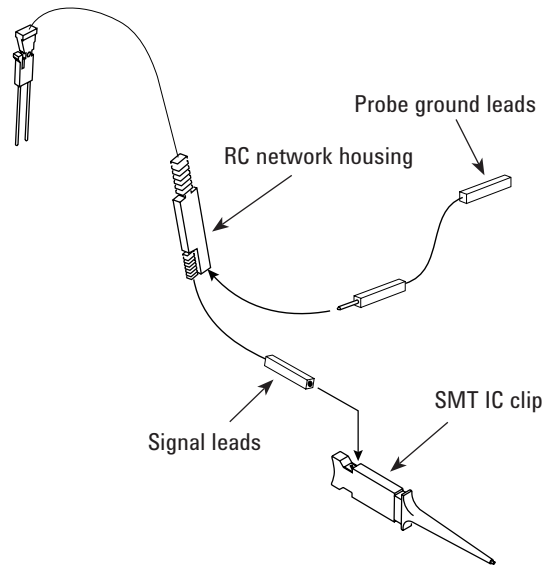

Figure 2.4. Connecting IC clips and ground leads to probes

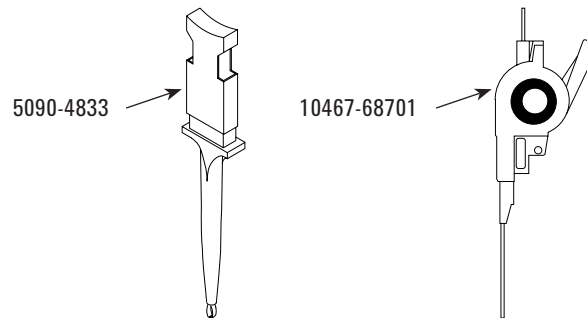

Figure 2.5. SMD IC clip and 0.5 mm IC clip

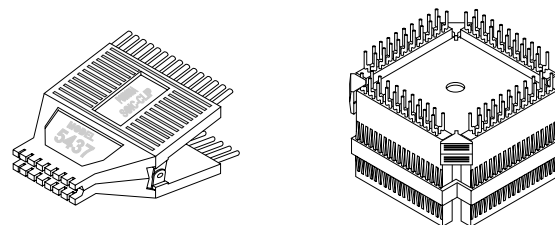

Figure 2.6. Typical IC test clips available from commercial test clip vendors

Probing Solutions for 40-pin Logic Analyzers

Designing for Logic Analysis Probing

Agilent recommends that targets with probing constraints have connectors designed into the prototype versions of the product for effective hardware and software debug. The following should be considered when designing with connectors:

- Select the appropriate connector technology for your target speed and target density.
- Carefully select all lines for routing to the connectors that may be needed for debug.
- Group the lines at each connector for your probing convenience. For example, Agilent may have written an inverse assembler for your device that has a preconfigured signal order. Before designing, refer to the documentation for this inverse assembler for essential signal lines and order.
- Keep the routing to connectors as short as possible to minimize target impact and provide accurate data.
- Examine the impact of probing isolation networks designed into the target versus the isolation network products offered by Agilent Technologies.

An isolation network must be located between the target and the logic analyzer. It can be located on the target board in through-hole or SMT parts; or it can be attached to the logic analyzer cable with the probe leads (the isolation network is molded into the end of the probe); or the Agilent 01650-63203 isolation adapter with self contained isolation networks can be used. Probe leads can be used with connectors but are not the most convenient method. Direct connection of the connectors with the analyzer cable (isolation network parts on the target) or with a probe or isolation adapter is the faster, more convenient method.

Probing Solutions for 40-pin Logic Analyzers

Soft Touch Connectorless Probing

High-density, high-performance probes

Agilent Pro Series soft touch connectorless logic analyzer probes

Agilent has developed connectorless logic analyzer probes based on soft touch probing technology. Connectorless logic analyzer probing removes the connector that is traditionally attached to the target board and replaces it with an array of probe pads. This reduces the probe load on the target by eliminating the loading associated with the physical body of the connector. Additionally, this streamlines the design flow by eliminating the need to assign a logic analyzer connector to the bill of material of your board, procuring those connectors and then having them loaded onto your board.

Agilent's soft touch connectorless probes use micro spring-pin technology to provide reliable contact which is not dependent on the planarity of

the PC board or the plating processes used to fabricate the board. No special cleaning processes are required when using Agilent's soft touch probes.

The new Agilent Technologies Pro Series soft touch connectorless probes offer a 30% smaller footprint than the original soft touch probes and are the basis for the industry standard connectorless probing footprint.

The probes use a retention module that ensures soft touch pin-to-PC board pad alignment and holds the probe in place while in use. The Pro Series soft touch uses a "top-side" mountable retention module. The retention module is mounted on the same side of the board as the probing footprint so there is no need to access the back-side of the board. Because there is no requirement for the retention module pins to extend beyond the back-side of the board, the retention module is compatible with virtually any board thickness.

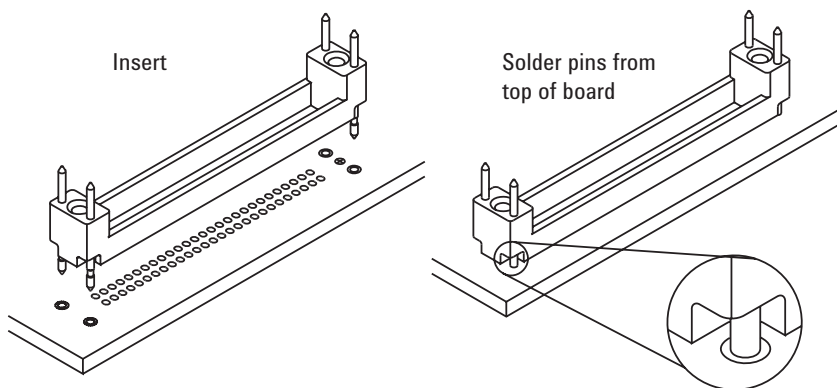

Figure 3.1. "Top-side" mountable retention module

E5404A Pro Series soft touch connectorless probe

The E5404A is a 34-channel single-ended Pro Series soft touch connectorless probe compatible with all Agilent logic analyzers that have a 40-pin pod connector. It is capable of acquiring data at the maximum rates of the logic analyzer it is connected to.

Features

- No connector on the target board
- Top-side mount retention module
- Industry-standard connectorless footprint
- 34 channels, single-ended clock and data
- Extremely low, < 0.7 pF, equivalent load capacitance
- Capable of data rates > 2.5 Gb/s (maximum rate dependent on analyzer used)
- 500 mV p-p minimum signal amplitude
- Robust and reliable soft touch technology

Unused clock inputs can be used as data inputs.

The E5404A (used with logic analyzers with a 40-pin cable connector) uses the same footprint, pinout, and retention module as the E5406A Pro Series soft touch connectorless probe (used with logic analyzers with a 90-pin cable connector).

A kit of five retention modules is shipped with each Pro Series soft touch probe. Additional kits can be ordered using Agilent part number E5403A.

Probing Solutions for 40-pin Logic Analyzers

Soft Touch Connectorless Probing

E5394A soft touch connectorless probe

The E5394A is a 34-channel single-ended soft touch connectorless probe compatible with all Agilent logic analyzers that have a 40-pin pod connector. It is capable of acquiring data at the maximum rates of the logic analyzer it is connected to. The probe has the following inputs:

- 32 single-ended data inputs
- two single-ended clock inputs
- < 0.7 pf input capacitance
- 500 mV p-p minimum signal amplitude

Unused clock inputs can be used as data inputs.

The E5394A (used with logic analyzers with a 40-pin pod connector) uses the same footprint, pinout and retention module as the E5390A single-ended soft touch connectorless probe (used with logic analyzers with a 90-pin pod connector).

A kit of five retention modules is shipped with each soft touch probe. Additional kits can be ordered using Agilent part number E5387-68701.

E5396A half-size soft touch connectorless probe

The E5396A is a small space saving probe compatible with all Agilent logic analyzers that have a 40-pin cable connector. It is a 17-channel, single-ended probe capable of capturing data at the maximum rates of the logic analyzer it is connected to. The probe has the following inputs:

- 16 single-ended data inputs
- one single-ended clock input
- < 0.7 pf equivalent load capacitance
- 500 mV p-p minimum signal amplitude

The unused clock input can be used as a data input.

The E5396A (used with logic analyzers with a 40-pin cable connector) uses the same footprint, pinout, and retention module as the E5398A single-ended soft touch connectorless probe (used with logic analyzers with a 90-pin cable connector).

More information about soft touch connectorless probes is available on the web at www.agilent.com/find/softtouch.

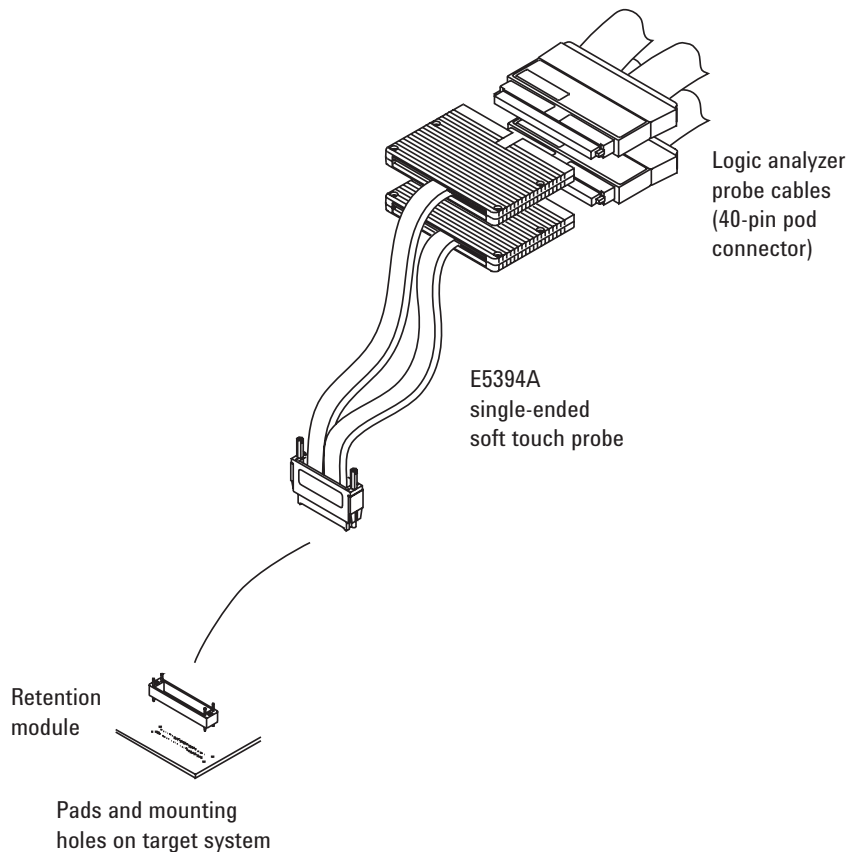

Figure 3.2. Agilent E5394A soft touch probe connection

Probing Solutions for 40-pin Logic Analyzers

Soft Touch Connectorless Probing

Probe dimensions

The following figures show dimensions, footprint, and pinout information you will need to design your target system board for use with the Agilent Pro Series soft touch probes.

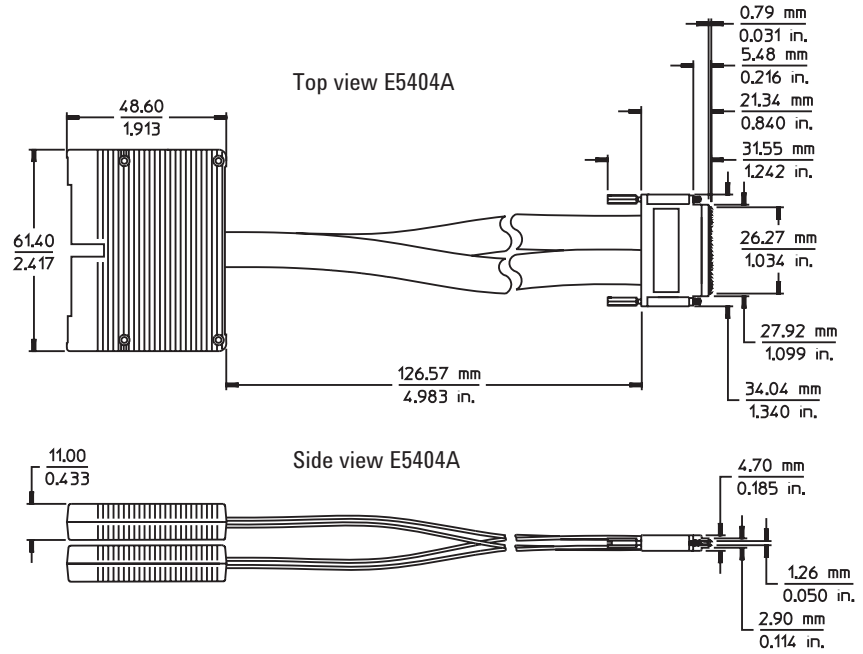

Figure 3.3. E5404A probe dimensions

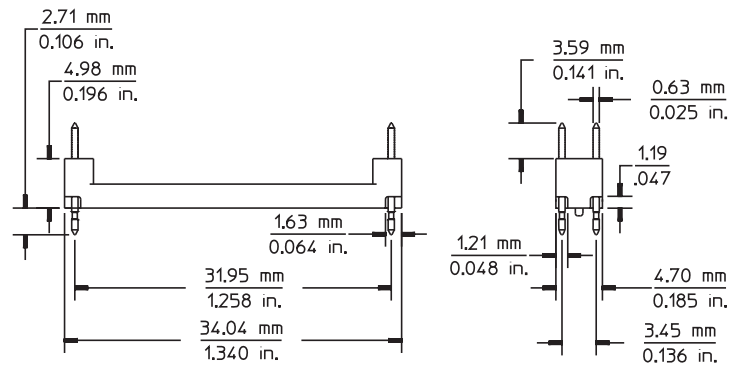

Figure 3.4. Pro Series soft touch retention module dimensions

Probe and retention module dimensions

The following dimensions show the Pro Series soft touch probe attached to the retention module. The retention module is mounted on the PC board.

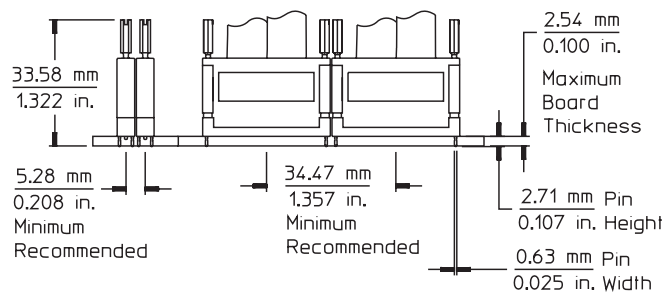
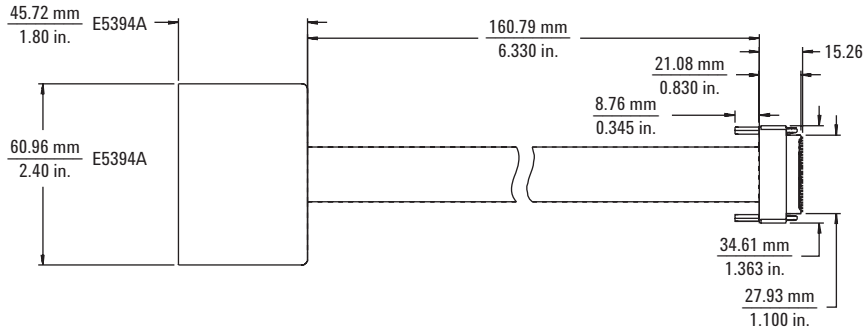

Figure 3.5. Pro Series soft touch side-by-side dimensions

Probing Solutions for 40-pin Logic Analyzers

Soft Touch Connectorless Probing

Top view E5394A



Side view E5394A

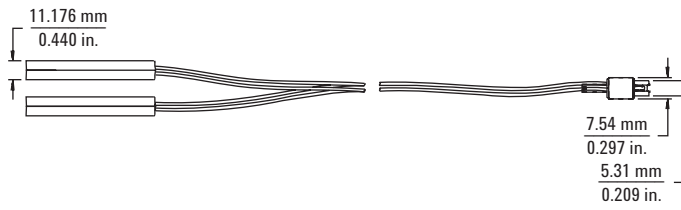

Top view E5396A

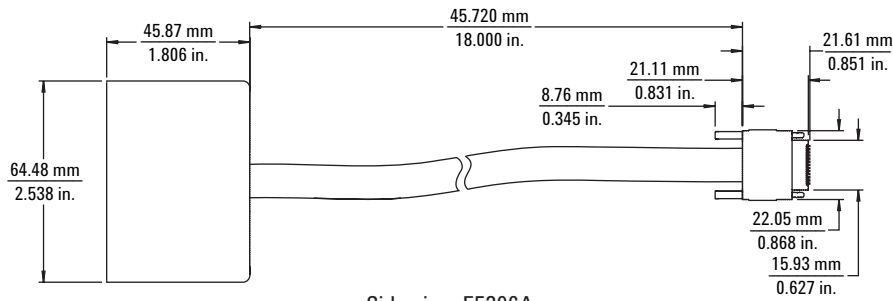

Side view E5396A



Figure 3.6. E5394A and E5396A soft touch probe dimensions

Probing Solutions for 40-pin Logic Analyzers

Soft Touch Connectorless Probing

Retention module dimensions

The soft touch probes are attached to the PC board using a retention module which ensures pin-to-pad alignment and holds the probe in place. A board thickness of up to 2.54 mm (0.100 inch) is recommended. Insert the retention module into the board, noting the keying pin, and solder the four alignment pins to the backside of the board.

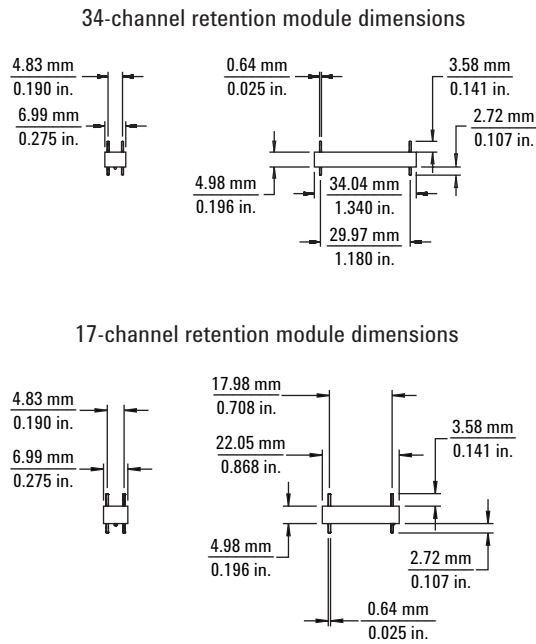

Figure 3.7. Retention module dimensions

Probe and retention module dimensions

The following dimensions show the soft touch probe attached to the retention module. The retention module is mounted on the PC board.

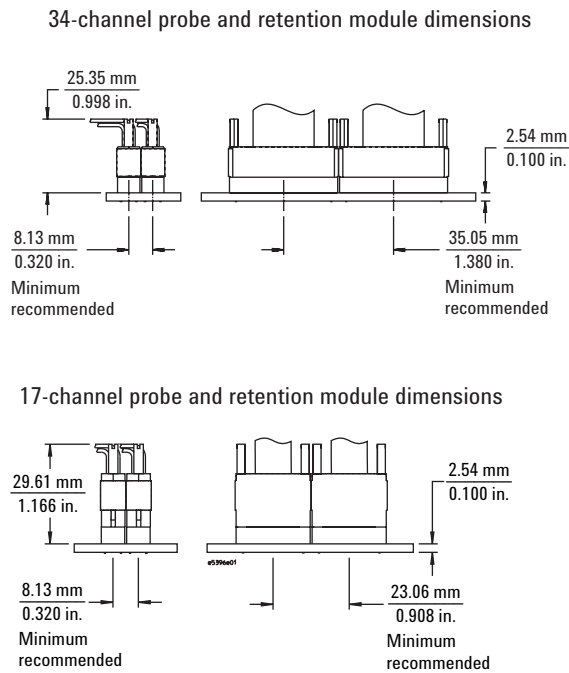

Figure 3.8. Side-by-side dimensions

Probing Solutions for 40-pin Logic Analyzers

Soft Touch Connectorless Probing

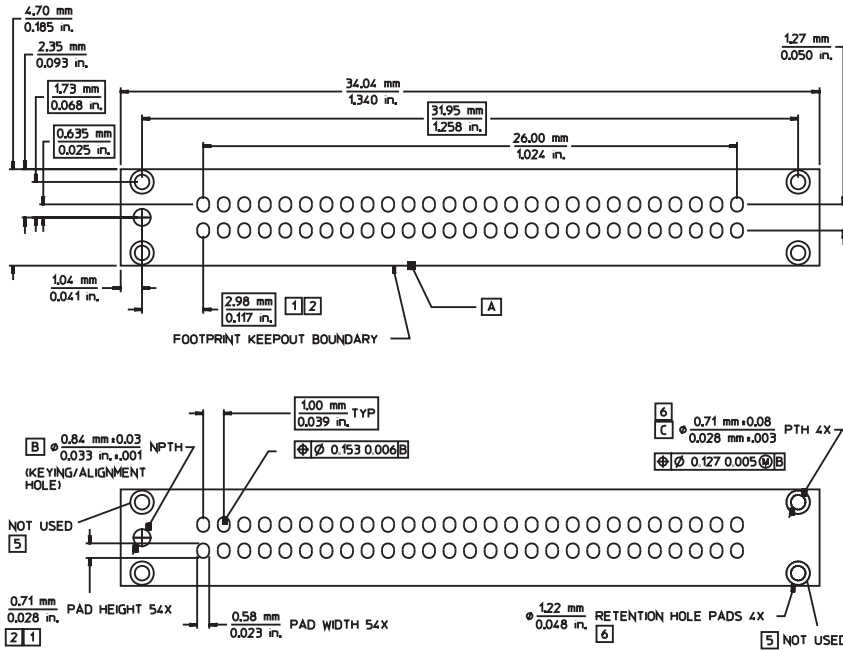
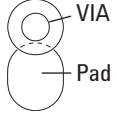

Figure 3.9. Pro Series soft touch footprint dimensions (see drawing notes)

Drawing notes:

- 1 Maintain a solder mask web between pads when traces are routed between the pads on the same layer. The solder mask may not encroach onto the pads within the pad dimension shown.
- 2 VIAs not allowed on these pads. VIA edges may be tangent to pad edges as long as a solder mask web between VIAs and pads is maintained. 
- 3 Surface finishes on pads should be HASL immersion silver, or gold over nickel.
- 4 This footprint is compatible with retention module Agilent part number E5405-68702.
- 5 This through hole is not used with the Agilent retention module.
- 6 Plated through hole should not be tied to ground plane for thermal relief.

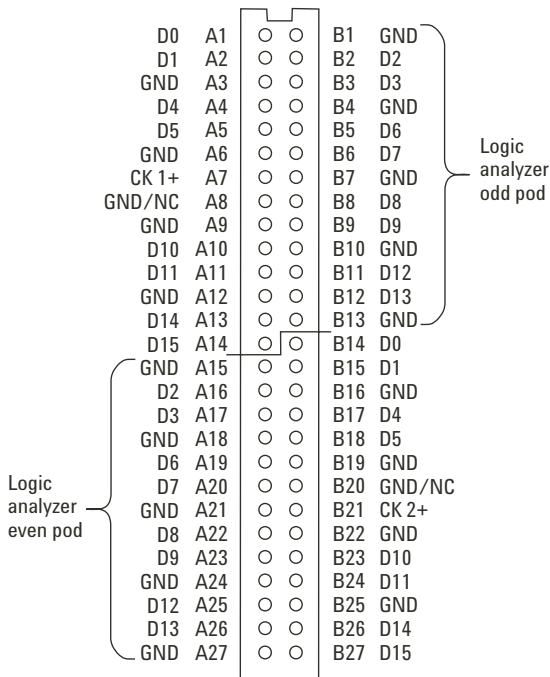

Figure 3.10. Pad numbers for E5404/06A 34-channel single-ended probes

Probing Solutions for 40-pin Logic Analyzers

Soft Touch Connectorless Probing

| E5404/06A 34-channel single-ended probe | | | | Logic analyzer |
|---|-------|---------|--|---|
| Signal name | Pad # | Channel | Pod | |
| D0 | A1 | → 0 | Whichever pod is connected to "Odd" on the E5404/06A probe | |
| D1 | A2 | → 1 | | |
| Ground | A3 | | | |
| D4 | A4 | → 4 | | |
| D5 | A5 | → 5 | | |
| Ground | A6 | | | |
| Clock 1+ | A7 | → Clock | | |
| GND/NC/Clock 1- | A8 | | | |
| Ground | A9 | | | |
| D10 | A10 | → 10 | | |
| D11 | A11 | → 11 | | |
| Ground | A12 | | | |
| D14 | A13 | → 14 | | |
| D15 | A14 | → 15 | | |
| Ground | A15 | | | Whichever pod is connected to "Even" on the E5404/06A probe |
| D2 | A16 | → 2 | | |
| D3 | A17 | → 3 | | |
| Ground | A18 | | | |
| D6 | A19 | → 6 | | |
| D7 | A20 | → 7 | | |
| Ground | A21 | | | |
| D8 | A22 | → 8 | | |
| D9 | A23 | → 9 | | |
| Ground | A24 | | | |
| D12 | A25 | → 12 | | |
| D13 | A26 | → 13 | | |
| Ground | A27 | | | |

| E5404/06A 34-channel single-ended probe | | | | Logic analyzer | |
|---|-------|---------|--|---|--|
| Signal name | Pad # | Channel | Pod | | |
| Ground | B1 | | Whichever pod is connected to "Odd" on the E5404/06A probe | | |
| D2 | B2 | → 2 | | | |
| D3 | B3 | → 3 | | | |
| Ground | B4 | | | | |
| D6 | B5 | → 6 | | | |
| D7 | B6 | → 7 | | | |
| Ground | B7 | | | | |
| D8 | B8 | → 8 | | | |
| D9 | B9 | → 9 | | | |
| Ground | B10 | | | | |
| D12 | B11 | → 12 | | | |
| D13 | B12 | → 13 | | | |
| Ground | B13 | | | | |
| D0 | B14 | → 0 | | Whichever pod is connected to "Even" on the E5404/06A probe | |
| D1 | B15 | → 1 | | | |
| Ground | B16 | | | | |
| D4 | B17 | → 4 | | | |
| D5 | B18 | → 5 | | | |
| Ground | B19 | | | | |
| GND/NC/Clock 2- | B20 | | | | |
| Clock 2+ | B21 | → Clock | | | |
| Ground | B22 | | | | |
| D10 | B23 | → 10 | | | |
| D11 | B24 | → 11 | | | |
| Ground | B25 | | | | |
| D14 | B26 | → 14 | | | |
| D15 | B27 | → 15 | | | |

Probing Solutions for 40-pin Logic Analyzers

Soft Touch Connectorless Probing

Pinout for the E5394A single-ended soft touch probe

The following graphic and table show the E5394A single-ended soft touch probe pad numbers and logic analyzer pod inputs.

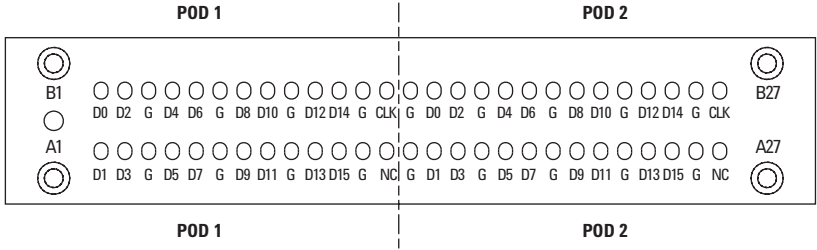

Figure 3.12. Pinout

| E5394A single-ended probe | | Logic analyzer | |
|---------------------------|-------|----------------|--|
| Signal name | Pad # | Channel | Pod |
| D1 | A1 | → 1 | Whichever pod is connected to "Odd" on the E5394A probe |
| D3 | A2 | → 3 | |
| Ground | A3 | | |
| D5 | A4 | → 5 | |
| D7 | A5 | → 7 | |
| Ground | A6 | | |
| D9 | A7 | → 9 | |
| D11 | A8 | → 11 | |
| Ground | A9 | | |
| D13 | A10 | → 13 | |
| D15 | A11 | → 15 | |
| Ground | A12 | | |
| NC | A13 | → NC | |
| Ground | A14 | | Whichever pod is connected to "Even" on the E5394A probe |
| D1 | A15 | → 1 | |
| D3 | A16 | → 3 | |
| Ground | A17 | | |
| D5 | A18 | → 5 | |
| D7 | A19 | → 7 | |
| Ground | A20 | | |
| D9 | A21 | → 9 | |
| D11 | A22 | → 11 | |
| Ground | A23 | | |
| D13 | A24 | → 13 | |
| D15 | A25 | → 15 | |
| Ground | A26 | | |
| NC | A27 | → NC | |

| E5394A single-ended probe | | Logic analyzer | |
|---------------------------|-------|----------------|--|
| Signal name | Pad # | Channel | Pod |
| D0 | B1 | → 0 | Whichever pod is connected to "Odd" on the E5394A probe |
| D2 | B2 | → 2 | |
| Ground | B3 | | |
| D4 | B4 | → 4 | |
| D6 | B5 | → 6 | |
| Ground | B6 | | |
| D8 | B7 | → 8 | |
| D10 | B8 | → 10 | |
| Ground | B9 | | |
| D12 | B10 | → 12 | |
| D14 | B11 | → 14 | |
| Ground | B12 | | |
| Clock | B13 | → Clock | |
| Ground | B14 | | Whichever pod is connected to "Even" on the E5394A probe |
| D0 | B15 | → 0 | |
| D2 | B16 | → 2 | |
| Ground | B17 | | |
| D4 | B18 | → 4 | |
| D6 | B19 | → 6 | |
| Ground | B20 | | |
| D8 | B21 | → 8 | |
| D10 | B22 | → 10 | |
| Ground | B23 | | |
| D12 | B24 | → 12 | |
| D14 | B25 | → 14 | |
| Ground | B26 | | |
| Clock | B27 | → Clock | |

Probing Solutions for 40-pin Logic Analyzers

Soft Touch Connectorless Probing

Pinout for the E5396A 17-channel single-ended soft touch probe

The following graphic and table show the E5396A single-ended soft touch probe pad numbers and logic analyzer pod inputs.

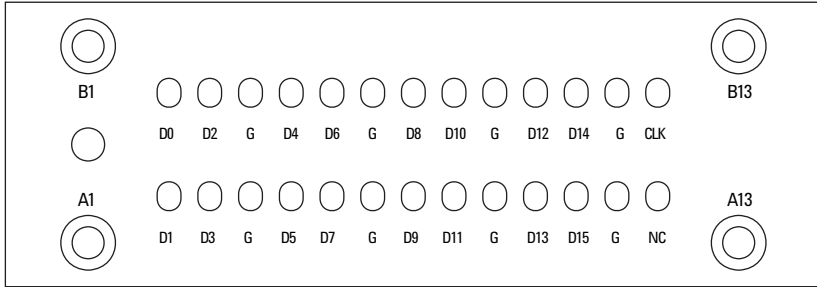

Figure 3.13. Pinout

| E5396A 17-channel single-ended probe | | Logic analyzer | |
|--------------------------------------|-------|----------------|--|
| Signal name | Pad # | Channel | Pod |
| D1 | A1 | → 1 | Whichever pod is plugged into the E5396A probe |
| D3 | A2 | → 3 | |
| Ground | A3 | | |
| D5 | A4 | → 5 | |
| D7 | A5 | → 7 | |
| Ground | A6 | | |
| D9 | A7 | → 9 | |
| D11 | A8 | → 11 | |
| Ground | A9 | | |
| D13 | A10 | → 13 | |
| D15 | A11 | → 15 | |
| Ground | A12 | | |
| NC | A13 | → n/a | |

| E5396A 17-channel single-ended probe | | Logic analyzer | |
|--------------------------------------|-------|----------------|--|
| Signal name | Pad # | Channel | Pod |
| D0 | B1 | → 0 | Whichever pod is plugged into the E5396A probe |
| D2 | B2 | → 2 | |
| Ground | B3 | | |
| D4 | B4 | → 4 | |
| D6 | B5 | → 6 | |
| Ground | B6 | | |
| D8 | B7 | → 8 | |
| D10 | B8 | → 10 | |
| Ground | B9 | | |
| D12 | B10 | → 12 | |
| D14 | B11 | → 14 | |
| Ground | B12 | | |
| Clock | B13 | → Clock | |

Probing Solutions for 40-pin Logic Analyzers

Soft Touch Connectorless Probing

Equivalent probe loads

The following probe load models are based on in-circuit measurements made with an Agilent 8753E 6 GHz network analyzer and an Agilent 54750A TDR/TDT using a 50 Ω test fixture. The following schematic accurately models the probe load out to 6 GHz.

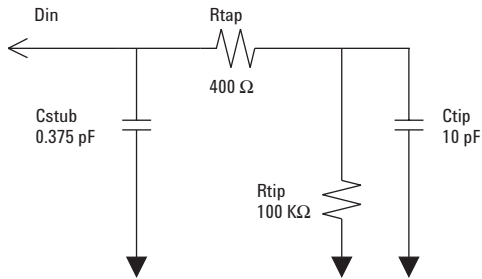

Figure 3.14. Simple (does not include capacitive coupling between channels or inductance of the spring pins)

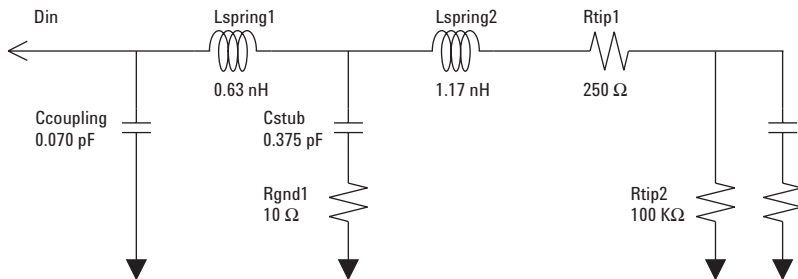

Figure 3.15. Complex (includes capacitive coupling between channels and inductance of spring pins)

Probing Solutions for 40-pin Logic Analyzers

Mictor and Samtec Probing

High-Density, High-Performance

Agilent has developed high-density probing solutions based on the 100-pin Samtec and AMP Mictor 38-pin connectors. The Agilent probes and adapter cables, E5346A, E5339A, E5351A, and E5385A provide a connection strategy to route your important signals to the Agilent logic analyzer. Simply design the connectors onto the board for the critical signals

such as address, data, and status bits. The connectors consume a minimal amount of board space. Each connector provides 32 channels of logic analysis per connector and two clocks (unused clocks can be used as data). Connectors for use with the E5385A, E5346A, E5339A, and E5351A can be purchased directly from AMP, Samtec, or Agilent Technologies. See the "Related Information" at the end of this document.

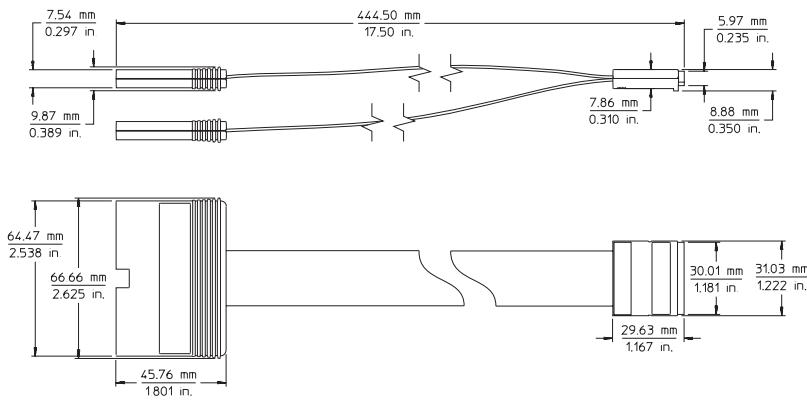

Figure 3.16. E5385A Samtec 100-pin probe mechanical dimensions

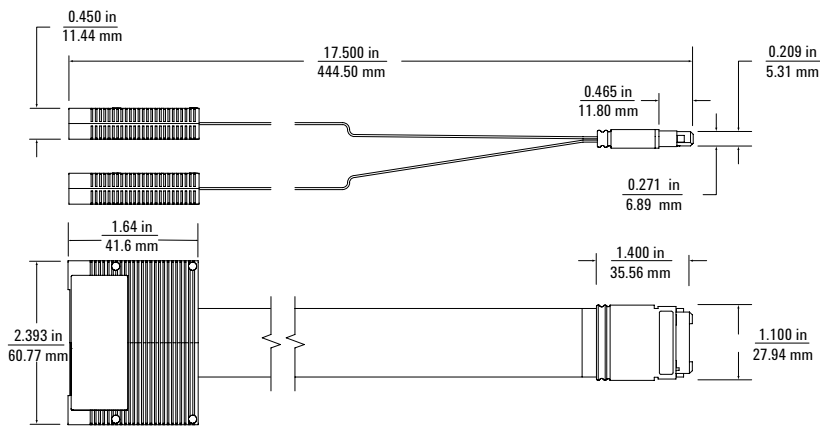

Figure 3.17. E5346A, E5351A, E5339A Mictor probes mechanical dimensions

Probing Solutions for 40-pin Logic Analyzers

Mictor and Samtec Probing

Agilent Technologies E5346A, E5339A, and E5385A probes

The E5346A, E5339A, and E5385A probes include the required isolation networks for the logic analyzer right at the probe tip, close to the target. The E5346A and E5385A are designed to acquire signals with peak-to-peak amplitude as low as 500 mV. The E5339A is designed to acquire signals as small as 250 mV peak-to-peak. Figure 3.18 shows the equivalent load for the E5339A, and Figure 3.19 shows the equivalent load for the E5346A. Figure 3.20 shows the equivalent load for the E5385A.

To use the E5346A, E5339A, or E5385A at high clock speeds, the following design guidelines should be observed:

- Calculate the electrical length of the probe hookup stub.
- For PC board material with $E_r=4.9$, use a propagation delay of 160 ps/inch.
- Check that the propagation delay of the probe hookup stub is less than 20% of the bus signal rise time (T_r). If it is, the E5346A, E5339A, or E5385A can be used for connection.

For example, if $E_r=4.9$, a 2.5 inch probe hookup stub generates a propagation delay of 400 ps. If T_r is > 2 ns, the E5346A, E5339A, or E5385A is a viable probing choice.

The E5346A and E5339A use the AMP Mictor 38-pin connector. The E5385A uses a 100-pin connector manufactured by Samtec. Agilent recommends the E5394A or E5385A for new applications, due to the reduced input capacitive loading and improved isolation between adjacent channels.

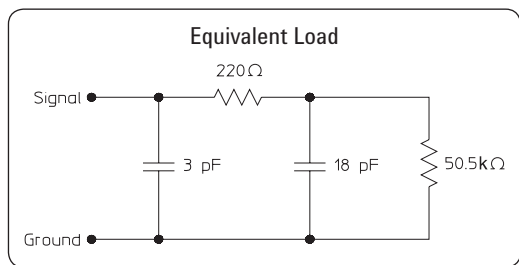

Figure 3.18. E5339A Low Voltage Mictor probe input equivalent load

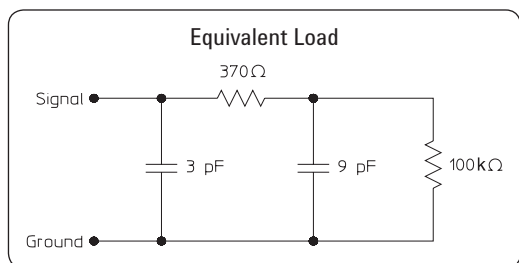

Figure 3.19. E5346A Mictor probe input equivalent load

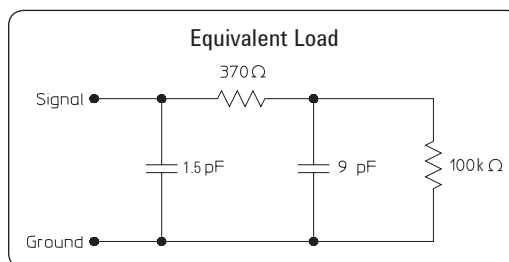

Figure 3.20. E5385A Samtec probe input equivalent load

For additional information on designing connectors into a target system, refer to the following documents:

| | | |
|--|-------------------------------|---|
| Agilent Technologies E5346A/E5351A Probe/Adapter Cable | Installation Note E5346-92014 | http://literature.agilent.com/litweb/pdf/E5346-92014.pdf |
| Agilent Technologies E5339A Low Voltage Probe | Installation Note E5339-92002 | http://literature.agilent.com/litweb/pdf/E5339-92002.pdf |
| Agilent Technologies E5385A Probe | Installation Note E5385-92001 | http://literature.agilent.com/litweb/pdf/E5385-92001.pdf |

Probing Solutions for 40-pin Logic Analyzers

Mictor and Samtec Probing

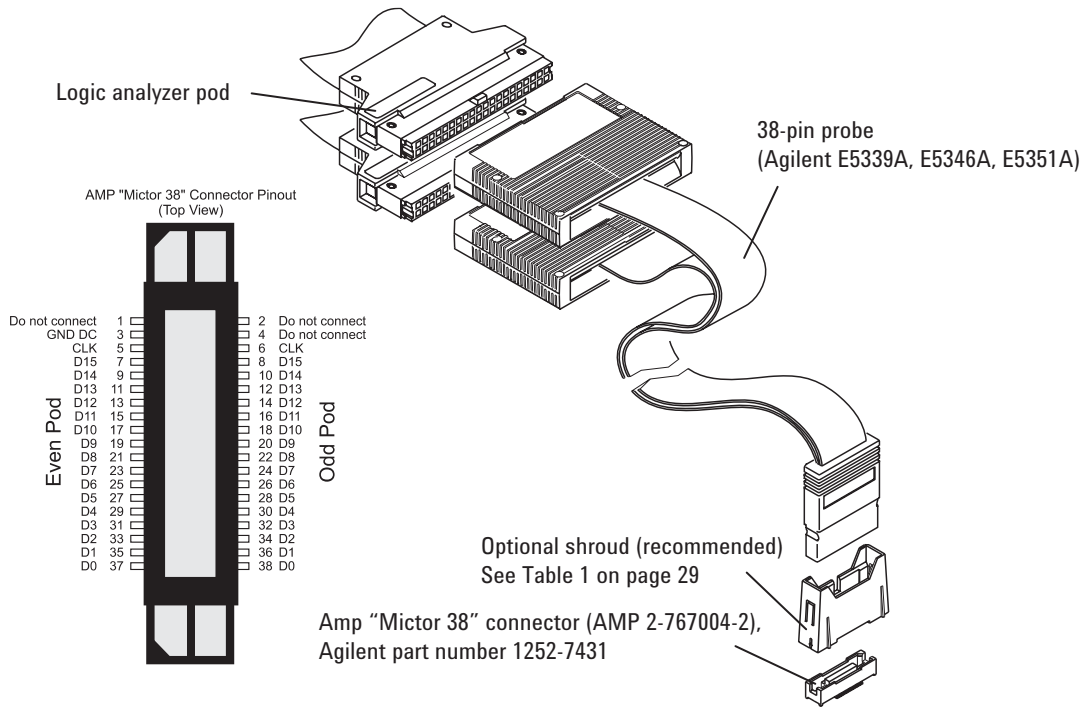

Figure 3.21. Agilent E5339A, E5346A, and E5351A connection and pinout

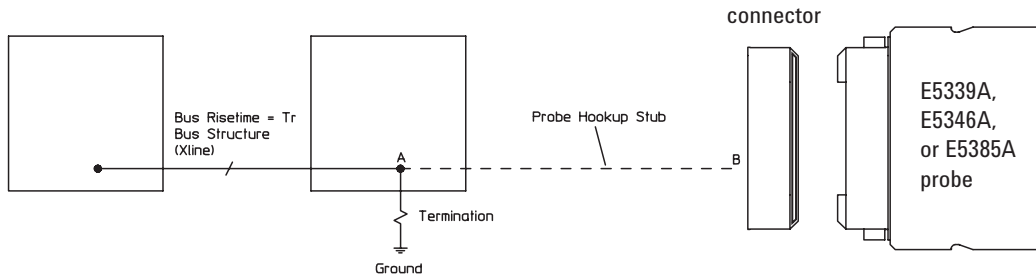

Figure 3.22. Agilent E5339A, E5346A, and E5385A design rules

Probing Solutions for 40-pin Logic Analyzers

Mictor and Samtec Probing

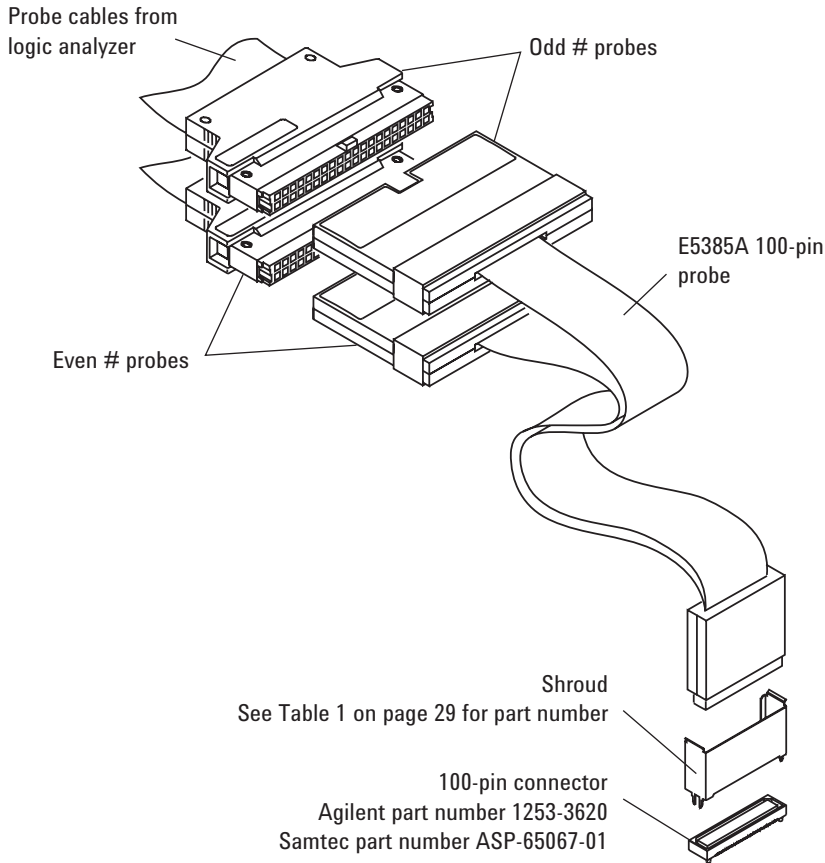

Figure 3.23. Agilent E5385A connection and pinout

E5385A 100-pin probe pin assignments

| Signal | Pin number | Signal | |
|----------------------|------------|--------|------------------------|
| Ground | 1 | 2 | Ground |
| Do Not Connect | 3 | 4 | Do Not Connect |
| Ground | 5 | 6 | Ground |
| Odd D0 | 7 | 8 | Even D0 |
| Ground | 9 | 10 | Ground |
| Odd D1 | 11 | 12 | Even D1 |
| Ground | 13 | 14 | Ground |
| Odd D2 | 15 | 16 | Even D2 |
| Ground | 17 | 18 | Ground |
| Odd D3 | 19 | 20 | Even D3 |
| Ground | 21 | 22 | Ground |
| Odd D4 | 23 | 24 | Even D4 |
| Ground | 25 | 26 | Ground |
| Odd D5 | 27 | 28 | Even D5 |
| Ground | 29 | 30 | Ground |
| Odd D6 | 31 | 32 | Even D6 |
| Ground | 33 | 34 | Ground |
| Odd D7 | 35 | 36 | Even D7 |
| Ground | 37 | 38 | Ground |
| Odd D8 | 39 | 40 | Even D8 |
| Ground | 41 | 42 | Ground |
| Odd D9 | 43 | 44 | Even D9 |
| Ground | 45 | 46 | Ground |
| Odd D10 | 47 | 48 | Even D10 |
| Ground | 49 | 50 | Ground |
| Odd D11 | 51 | 52 | Even D11 |
| Ground | 53 | 54 | Ground |
| Odd D12 | 55 | 56 | Even D12 |
| Ground | 57 | 58 | Ground |
| Odd D13 | 59 | 60 | Even D13 |
| Ground | 61 | 62 | Ground |
| Odd D14 | 63 | 64 | Even D14 |
| Ground | 65 | 66 | Ground |
| Odd D15 | 67 | 68 | Even D15 |
| Ground | 69 | 70 | Ground |
| NC | 71 | 72 | NC |
| Ground | 73 | 74 | Ground |
| NC | 75 | 76 | NC |
| Ground | 77 | 78 | Ground |
| Odd D16P/ Odd CLK | 79 | 80 | Even D16P/ Even CLK |
| Ground | 81 | 82 | Ground |
| NC | 83 | 84 | NC |
| Ground | 85 | 86 | Ground |
| NC | 87 | 88 | NC |
| Ground | 89 | 90 | Ground |
| NC | 91 | 92 | NC |
| Ground | 93 | 94 | Ground |
| Ground | 95 | 96 | Ground |
| +5V | 97 | 98 | +5V |
| +5V | 99 | 100 | +5V |

Probing Solutions for 40-pin Logic Analyzers

Mictor and Samtec Probing

Agilent E5351A 38-pin adapter cable

If the calculated electrical length of the required routing stub prohibits the use of the Agilent E5339A, E5346A, or E5385A, the Agilent E5351A can be used with the required isolation networks installed on the target.

The E5351A does not have its own internal isolation networks. When using the E5351A, place the SIP isolation networks, surface mount isolation network 5062-7396, or equivalent discrete components very near the target component for mea-

surement. Ensure that the stub length between the target component and the isolation network is short. The stub propagation delay should be less than 20% of the bus signal rise time, as mentioned before. The transmission line from the on-board isolation network to the Mictor connector should be designed for an impedance in the range of 80 to 100 ohms (closer to 100 ohms is better). This length should not exceed 3 to 4 inches, and all signal line lengths should be equal. Signal line length variation should not cause propagation delay variation to exceed 20 ps between signal lines.

Notes on using discrete components

Discrete components can be used in the design of the RC network. Agilent recommends the circuit shown in Figure 3.25. To achieve the equivalent load shown in the figure, trace lengths should be minimized by locating the RC network very near the measured node. Actual load will be the stub length load added to the equivalent load in the figure.

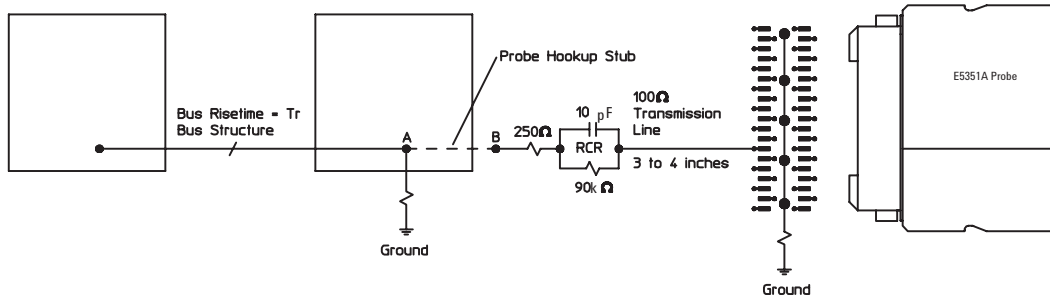

Figure 3.24. Agilent E5351A design rules

Probing Solutions for 40-pin Logic Analyzers

Mictor and Samtec Probing

Options for on-board terminations for the E5351A

There are two options for isolating the E5351A on the target PC board:

- Use the surface mount isolation network, Agilent part number 5062-7396. Refer to Figure 3.26 for schematic and pinout.
- Use discrete components. Refer to Figure 3.25 for recommended components and equivalent load.

If you are operating at state speeds above 200 MHz, you should use discrete components for best results. Due to the added electrical length of the E5351A probe cable, the divider compensating capacitors in the SIP, and surface-mount isolation networks are not optimum for the E5351A, but they are usable up to 200 MHz clock rates.

Notes on using the 5062-7396 SMT part

Agilent currently recommends a two-step process in soldering the SMT part to the board. The first pass places solder paste on those pads with vias. Application of heat allows the via to fill with solder. (If only one solder step is used, the solder wicks away from the part into the via and a solid connection will not be made with the part.) The next pass places solder paste on all of the pads.

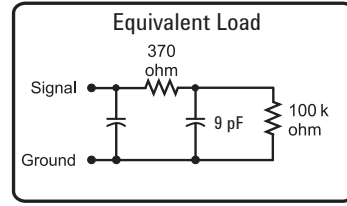
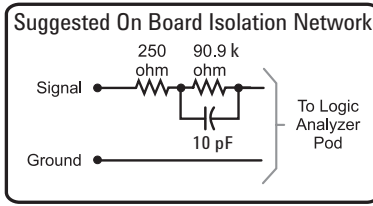

Includes on board RC network and logic analyzer

Figure 3.25. Suggested on-board isolation network and equivalent load when using discrete components to terminate the E5351A

Note 1. The effective input capacitance for on-board isolation networks is purely a function of geometry - 0.3 pF is about as low as can be achieved.

Note 2. The equivalent load is the same when using the surface-mount isolation network, 5062-7396.

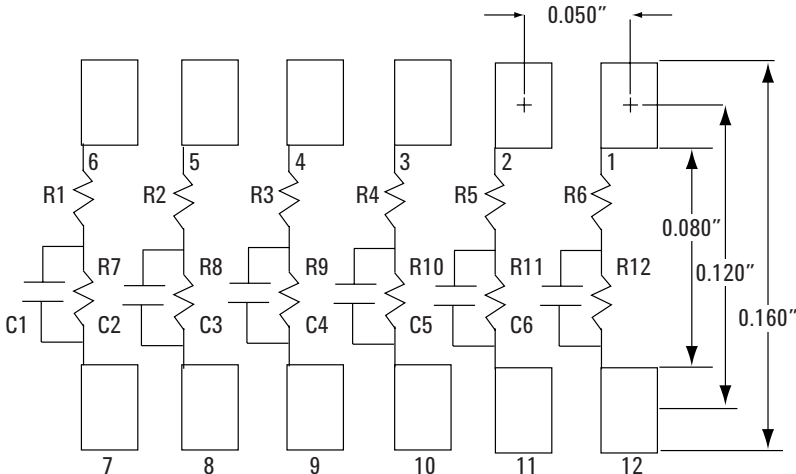

Logic analyzer pod pad dimension = 0.030" x 0.040"

Note 1. Resistances:
R1 through R6: 250 Ω
R7 through R12: 90.9 k Ω

Note 2. Capacitance 8.2 pF

Figure 3.26. Recommended PC board pattern for 5062-7396 surface mount isolation network

As shown in Figure 3.26, the 5062-7396 SMT isolation network supports six logic analysis channels. The size of the part allows you to repeat the pattern in Figure 3.26 to accommodate multiple parts stacked end-to-end for the number of channels needed in your application. Three of these SMTs are required for each

probe cable. The process for using the ceramic hybrid isolation network is similar to the process for an LCC package. Due to the small part size, thermal expansion mismatch during solder reflow should not be a problem. Capacitance also remains stable with temperature changes.

Probing Solutions for 40-pin Logic Analyzers

Mictor and Samtec Probing

Support shrouds

A support shroud is recommended to provide additional strain relief between the probe and the connector, as shown in Figures 3.21 and 3.23. Two plated through-holes are required on the target board. The shroud is mounted directly to the target board using the through-holes. This places the shroud around the connector, providing solid mechanical strain relief. Connector kits are available; Table 1 shows the Agilent part numbers for shrouds and connector kits for various PC board thicknesses.

Table 1. Mating connectors, shrouds, and kits for Agilent E5339A, E5346A, E5351A, and E5385A probes

| For probe model numbers | Description | Agilent part number |
|-------------------------|--|---------------------|
| E5339A, E5346A, E5351A | Kit of five support shrouds and five 38-pin Mictor connectors for PC board thickness up to 1.57 mm (0.062") | E5346-68701 |
| | Kit of five support shrouds and five 38-pin Mictor connectors for PC board thickness up to 3.175 mm (0.125") | E5346-68700 |
| | One 38-pin Mictor connector (also available from AMP as part number 2-767004-2) | 1252-7431 |
| | One support shroud for PC board thickness up to 1.57 mm (0.062") | E5346-44701 |
| | One support shroud for PC board thickness up to 3.175 mm (0.125") | E5346-44704 |
| | One support shroud for PC board thickness up to 4.318 mm (0.700") | E5346-44703 |
| E5385A | Kit of five support shrouds and five 100-pin Samtec connectors for PC board thickness up to 1.57 mm (0.062") | 16760-68702 |
| | Kit of five support shrouds and five 100-pin Samtec connectors for PC board thickness up to 3.05 mm (0.120") | 16760-68703 |
| | One 100-pin Samtec connector (also available from Samtec as part number ASP-65067-01) | 1253-3620 |
| | One support shroud for PC board thickness up to 1.57 mm (0.062") | 16760-02302 |
| | One support shroud for PC board thickness up to 3.05 mm (0.120") | 16760-02303 |

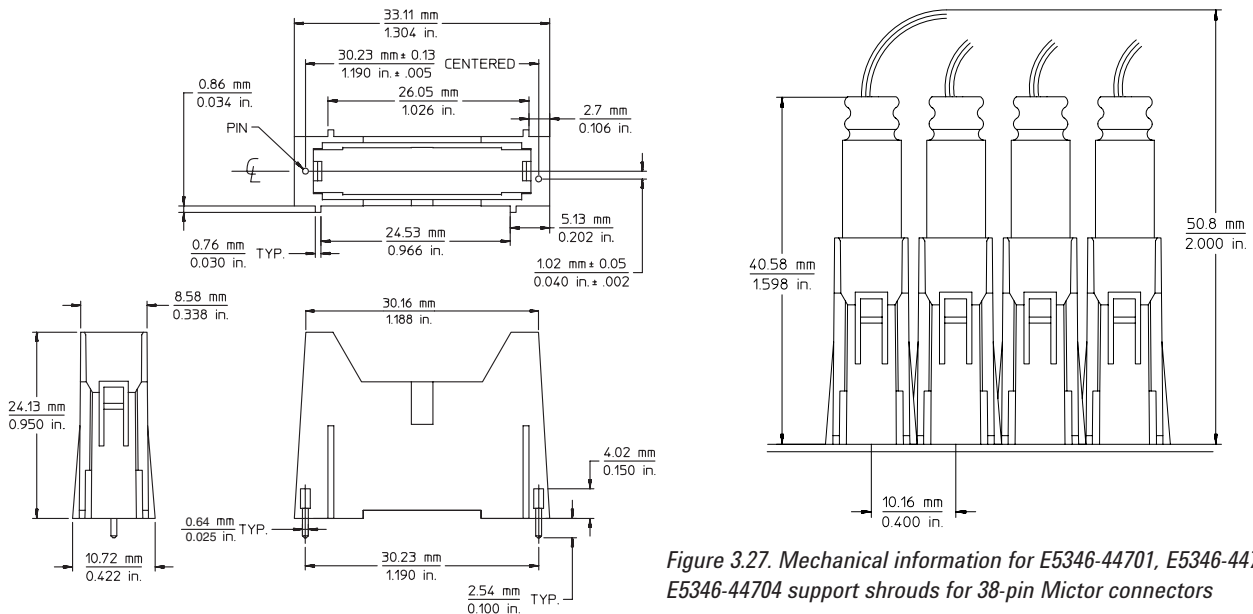

Figure 3.27. Mechanical information for E5346-44701, E5346-44703, E5346-44704 support shrouds for 38-pin Mictor connectors

Probing Solutions for 40-pin Logic Analyzers

Mictor and Samtec Probing

Right-angle Mictor adapter

For systems with space constraints above the 38-pin connector, Agilent offers a right-angle adapter, as shown in Figure 4.1. With the E5346-63201 right-angle adapter inserted in the 38-pin connector, the adapter cable is connected parallel to the target board surface. When using the right-angle adapters, the 38-pin connectors must be placed end-to-end on the target board, as shown in Figure 4.2. Support shrouds cannot be used with the right-angle adapter.

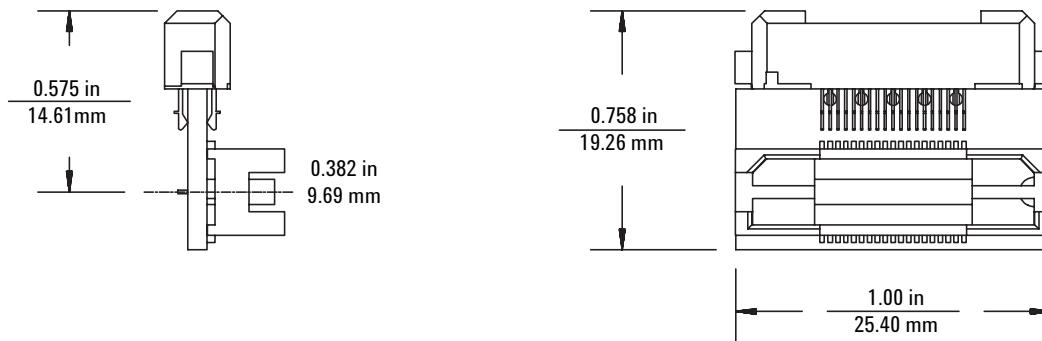
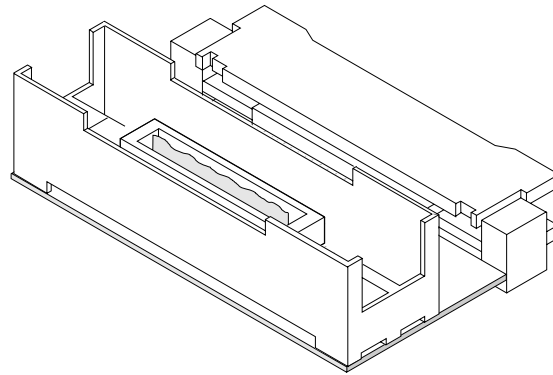

Figure 4.1. E5346-63201 right-angle 38-pin adapter

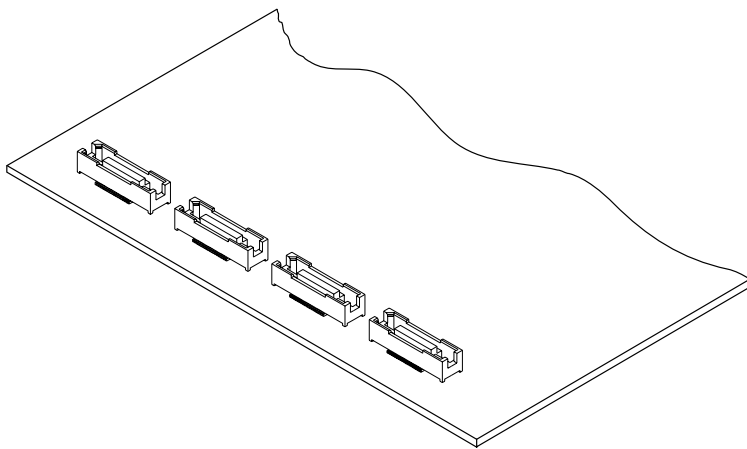

Figure 4.2. 38-pin connectors placed for use of right-angle adapter

Note. The right-angle adapter adds significant capacitance and inductance in series with the probe. It is not recommended for state speeds above 100 MHz or for signals with rise times < 4 to 5 ns.

Probing Solutions for 40-pin Logic Analyzers

Custom Probing

Low density, moderate performance

Solutions shown in the “High-Density, High-Performance” (page 23) section of this document can be used in place of the solutions described here. Agilent recommends standard 0.1 inch center connectors for normal density applications if the loading/speed is not a significant issue. Many of these items are available from 3M or Agilent (see Table 2). See the “Related Information” section at the end of this document for 3M address information.

Direct connection through isolation adapter

Isolation adapters (Agilent part number 01650-63203) that connect to the end of the probe cable are designed to perform two functions. The first is to reduce the number of pins required for the header on the target board from 40 pins to 20 pins. This process reduces the board area dedicated to the probing connection. The second function is to provide the proper RC networks in a very convenient package. Figure 4.3 illustrates how the isolation adapter physically connects to the target system and the equivalent load of the isolation adapter connected to an Agilent logic analyzer. Figures 4.4 and 4.5 show the pinout diagrams for the probe cable and the isolation adapter, respectively. There are two 20-pin connectors, along with their Agilent and 3M part numbers, listed in Table 2.

Table 2. Twenty-pin connectors for fixed configuration probing. (Requires isolation adapter)

| Agilent part number | 3M part number | Connector description |
|---------------------|----------------|-----------------------------------|
| 1251-8106 | 2520-6002 | 20-pin, low-profile (straight) |
| 1251-8473 | 2520-5002 | 20-pin, low-profile (right-angle) |

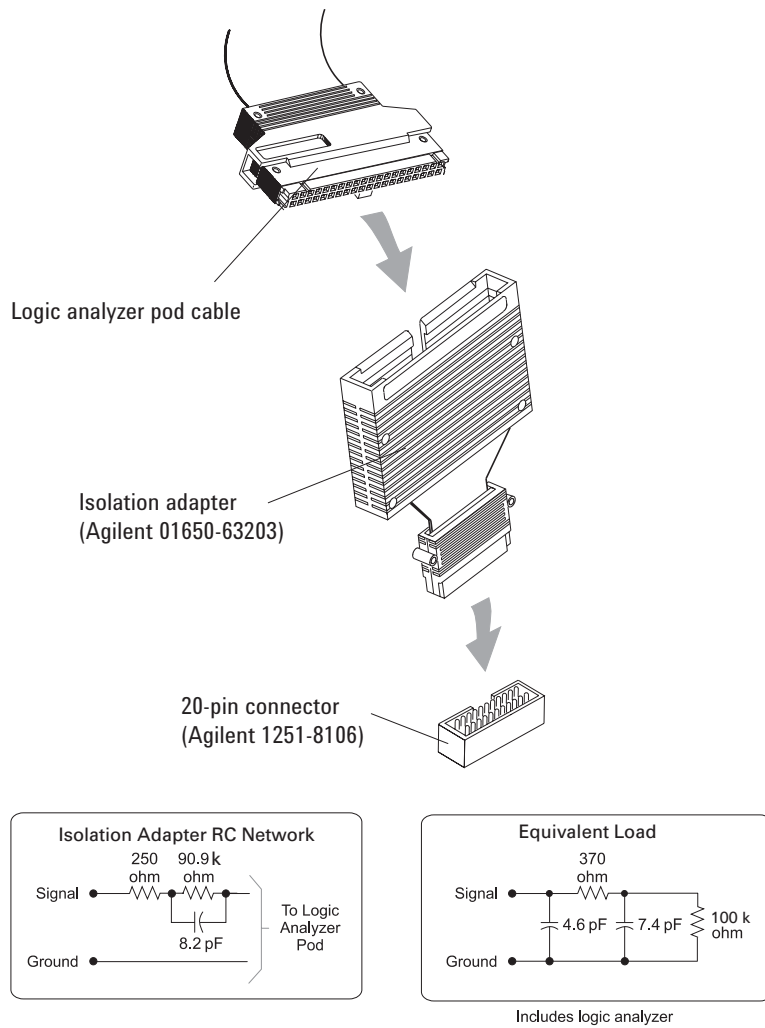

Figure 4.3. Isolation adapter (01650-63203) and equivalent load

Note. The Agilent 01650-63203 saves space by using a common ground (see Figure 4.5). This will impact signal fidelity, especially faster transition times (< 4 to 5 ns).

Probing Solutions for 40-pin Logic Analyzers

Custom Probing

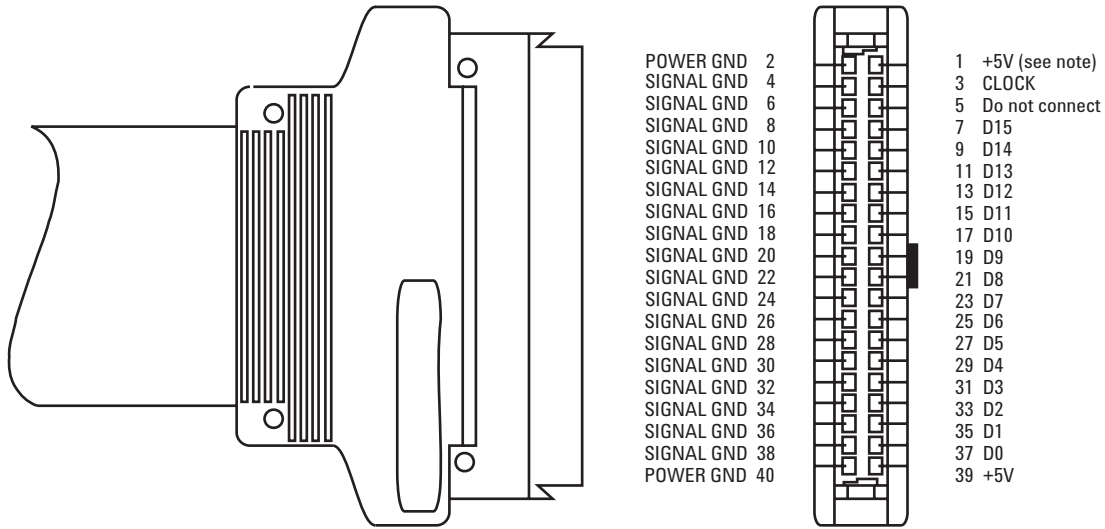

Figure 4.4. Pinout for probe cable

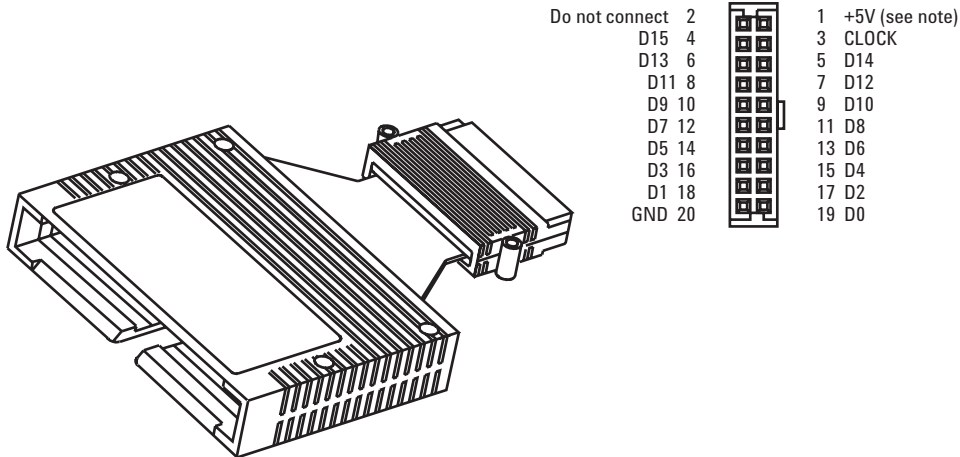

Figure 4.5. Pinout for 100 kΩ isolation adapter (Agilent part number 01650-63203)

Note. +5 V is supplied from the logic analyzer to provide power for analysis probes and demo boards. **DO NOT connect these pins to a +5 V supply in the target system!**

Probing Solutions for 40-pin Logic Analyzers

Custom Probing

Direct connection through 40-pin connectors

The probe cable also can be plugged directly into the various 40-pin connectors shown in Table 3, but proper isolation networks must be installed directly onto the target system board (see Figure 4.6 for the 40-pin connector pinout).

Agilent offers a 12-pin SMT (Agilent part number 5062-7396), which provides six isolation networks, as shown in Figure 4.7. Three of these SMTs are required for each probe cable.

Discrete components can also be used for the proper isolation network. See Figure 4.9 for an equivalent load diagram for the isolation networks.

Note that the effective input capacitive lead of an isolation network using discrete components is a function of the layout geometry and the parasitic capacitance of the input series damping resistor.

Table 3. Forty-pin connectors for fixed configuration probing. (Requires isolation network installed on target board)

| Agilent part number | 3M part number | Connector description |
|---------------------|----------------|---|
| 1251-8158 | 2540-5002 | 40-Pin, low-profile (right-angle) |
| 1251-8831 | 3432-6302 | 40-Pin, with long latches (straight) |
| 1251-8931 | 3432-5302 | 40-Pin, with long latches (right-angle) |

Table 4. Available isolation networks

| Agilent part number | Package type |
|---------------------|---|
| 5062-7396 | SMT, 12-pin, provides 6 isolation networks (3 SMTs required for each probe cable) |

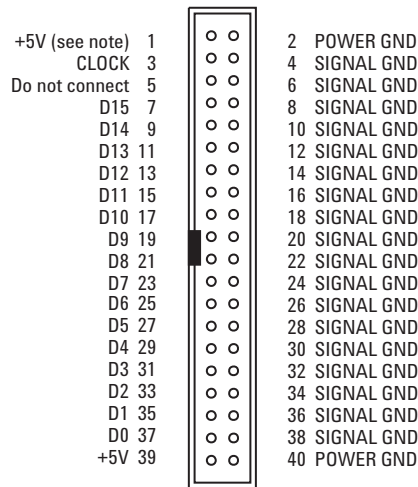
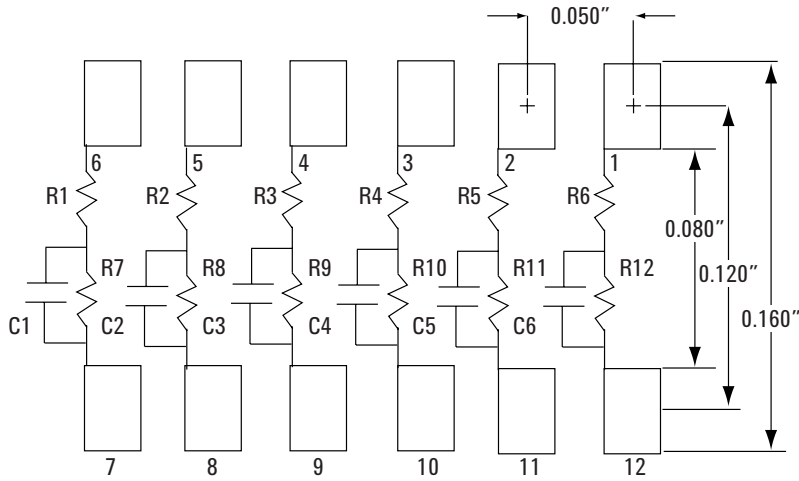

Figure 4.6. Forty-pin connector pinout

Note. +5 V is supplied from the logic analyzer to provide power for analysis probes and demo boards. **DO NOT connect these pins to a +5 V supply in the target system!**

Probing Solutions for 40-pin Logic Analyzers

Custom Probing



Logic analyzer pod pad dimension = 0.030" x 0.040"

Note 1. Resistances:

R1 through R6: 250 Ω

R7 through R12: 90.9 kΩ

Note 2. Capacitance 8.2 pF

Figure 4.7. Recommended PC board pattern for 5062-7396 surface mount isolation network

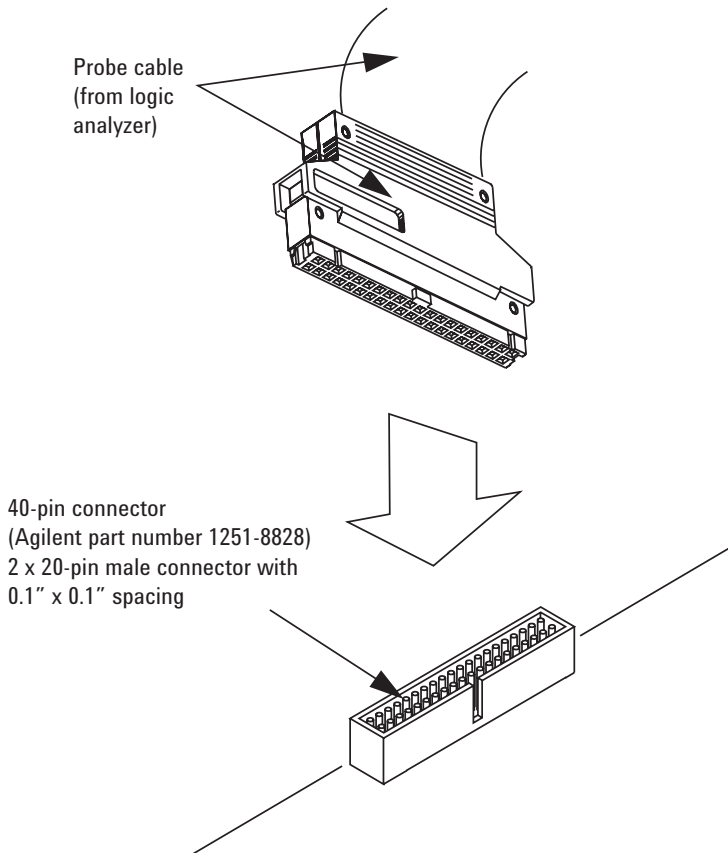

Figure 4.8. Connecting probe cable to 40-pin connector with isolation networks

Probing Solutions for 40-pin Logic Analyzers

Custom Probing

Notes on using discrete components

Discrete components can be used to design the isolation network. Agilent recommends the circuit shown in Figure 4.9. To achieve the equivalent load shown in the figure, trace lengths should be minimized by locating the RC network very near the measured node. Actual load will be the stub length load added to the equivalent load in the figure. Trace length from the suggested on-board RC network to the target connector must be 3 to 4 inches or less. This transmission line should be designed for an impedance in the range of 80 to 100 ohms (closer to 100 ohms is better).

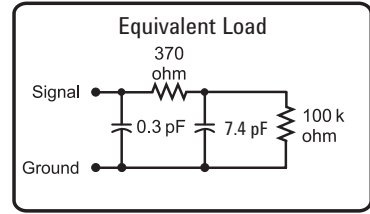
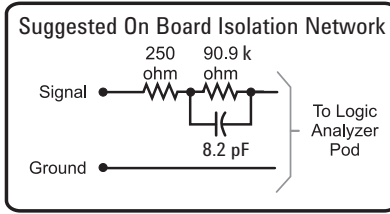

Includes on board isolation network and logic analyzer

Figure 4.9. Equivalent load for on-target discrete components. Also applies to SMT (5062-7396) RC networks.

Probing Solutions for 90-pin Logic Analyzers

General-Purpose Probing



E5382A single-ended flying lead probe set

The E5382A is a 17-channel single-ended flying lead probe compatible with logic analyzers with a 90-pin pod connection. It is capable of acquiring data at the maximum rates of the logic analyzer it is connected to. The E5382A is useful for acquiring signals from dispersed locations or when a mass connection scheme is not available. The E5382A has the following:

- 16 single-ended data inputs
- One differential or single-ended clock input
- Variety of supplied accessories

Unused clock inputs can be used as data inputs.

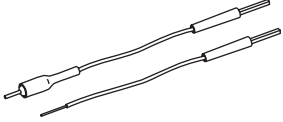
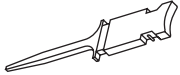
Table 5. Accessories

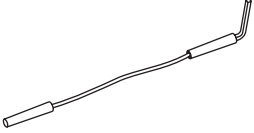
| | Part number | Description |
|---|-------------|---|
|  | E5382-82102 | Probe pin kit, 2 resistive pins per kit |
|  | E5382-82101 | High-frequency probing kit, 2 resistive signal wires and 4 ground wires per kit |
|  | 16517-82109 | Grabber clip kit, 20 grabbers per kit |
|  | 16517-82105 | Ground extender kit, 20 ground extenders per kit |
|  | 16517-82106 | Right-angle ground lead kit, 20 ground leads per kit |

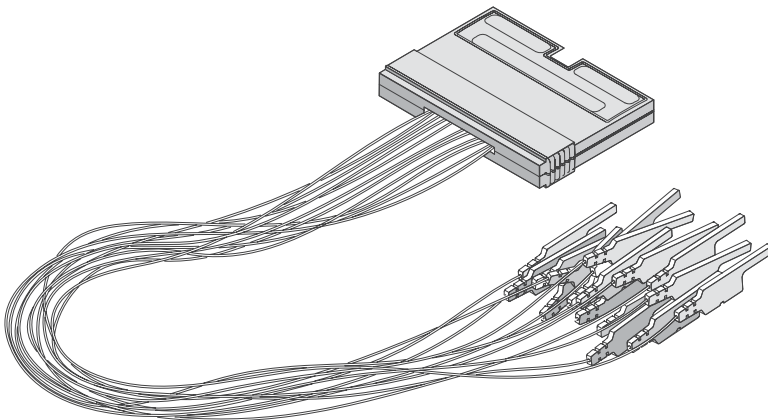



Figure 5.1. E5382A flying lead set

Probing Solutions for 90-pin Logic Analyzers

General-Purpose Probing

Suggested configurations and characteristics

Table 6. E5382A suggested configurations and characteristics

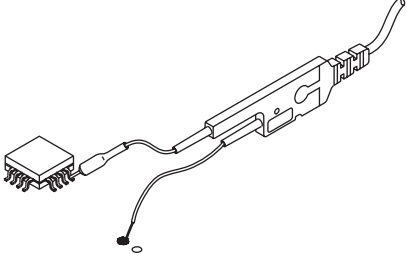
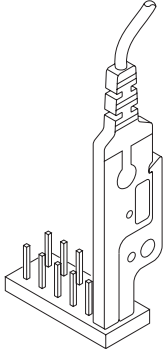
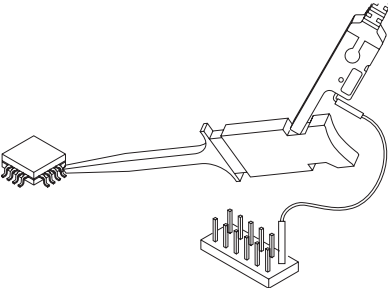
| Configuration | Description | Total lumped input C | Maximum recommended state speed |
|---|---|----------------------|---------------------------------|
|  | 130 Ω resistive signal pin (orange) and solder-down ground lead | 1.3 pF | 1.5 Gb/s |
|  | 5 cm resistive signal lead (can be soldered-down) and solder-down ground lead | 1.6 pF | 1.5 Gb/s |
|  | Flying lead and ground extender | 1.4 pF | 1.5 Gb/s |
|  | Grabber clip and right-angle 2.0 pf ground lead | 2.0 pF | 600 Mb/s |

Probing Solutions for 90-pin Logic Analyzers

General-Purpose Probing

Available accessories

Ground connector

It is essential to ground every tip that is in use. For best performance at high speeds, every tip should be grounded individually to ground in the system under test.

Adapting to coaxial connectors

The Agilent E9638A probe tip to BNC adapter can be used to connect one of the flying lead probes of the E5382A to a BNC connector. To probe other coaxial connectors, use the E9638A adapter, a BNC termination, and an adapter to the other type of coaxial connector. Refer to Figure 5.3.

NOTE: Examples of convenient connection which may result in degraded performance

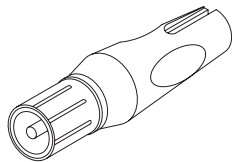
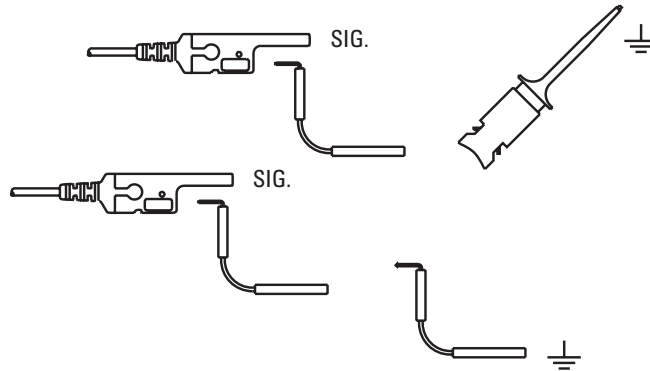

Figure 5.2. 5063-2174 BNC to probe tip adapter

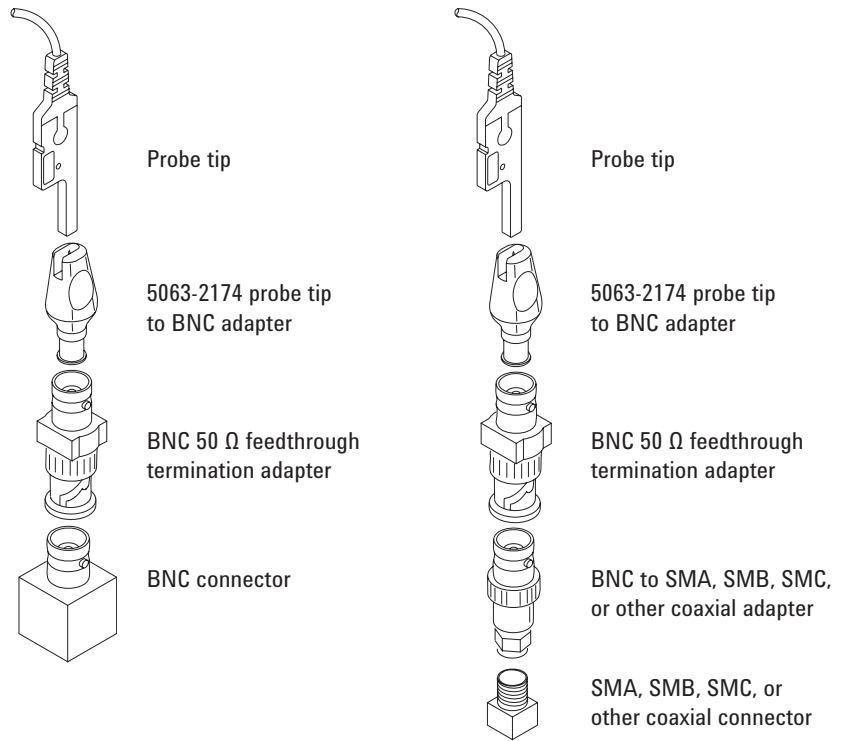

Figure 5.3. Recommended configurations to probe RF coaxial connectors with the E5382A flying lead probes

Probing Solutions for 90-pin Logic Analyzers

General-Purpose Probing

E5381A differential flying-lead probe set

The E5381A is a 17-channel differential flying-lead probe compatible with logic analyzers with a 90-pin pod connection. It is capable of acquiring data at the maximum rates of the logic analyzer it is connected to. The E5381A is useful for acquiring signals from dispersed locations or when a mass connection scheme is not available. The E5381A has the following:

- 16 differential or single-ended data inputs
- One differential or single-ended clock input
- Variety of supplied accessories

Unused clock inputs can be used as data inputs.

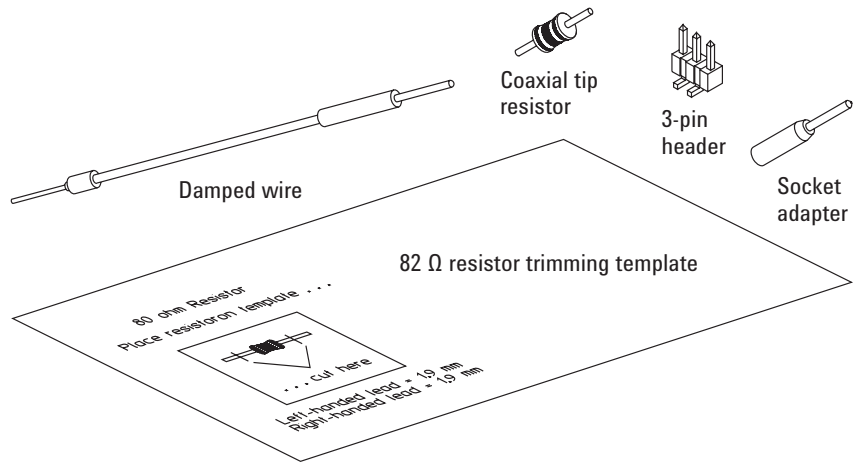

Figure 5.4. E5381A differential flying-lead probe set accessories

Replaceable parts and additional accessories

| Description | Quantity | Agilent part number |
|--|----------|---------------------|
| 82 Ω resistor trimming template | 1 | 01131-94309 |
| Accessory kit - coaxial tip resistors (82 Ω) | 34 | E5381-82101 |
| Accessory kit - socket adapter | 34 | E5381-82102 |
| Accessory kit - damped wire (160 Ω) | 34 | E5381-82103 |
| Accessory kit - 3-pin header | 34 | E5381-82104 |
| Cable - main | 1 | E5381-61601 |

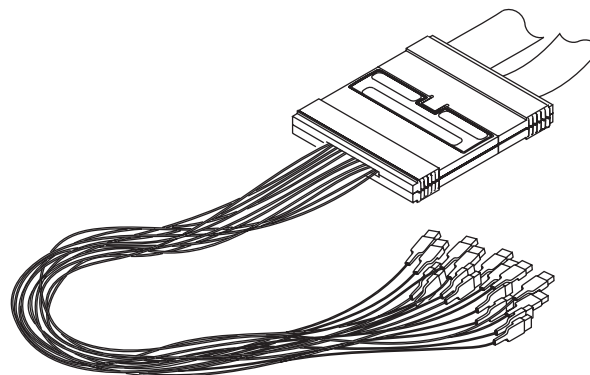

Figure 5.5. E5381A differential flying-lead probe set

Probing Solutions for 90-pin Logic Analyzers

General-Purpose Probing

Suggested configurations and characteristics

Table 7. E5381A suggested configurations and characteristics

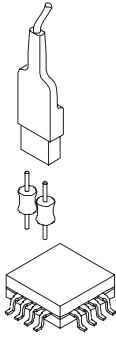
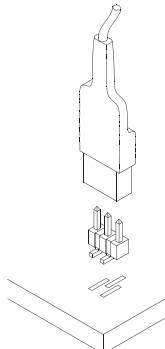
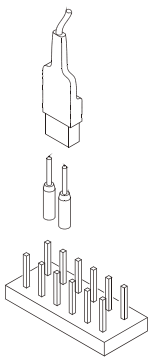
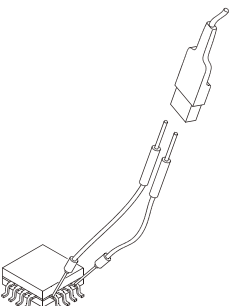
| Configuration | Description | Total lumped input C | Maximum recommended state speed |
|---|--|----------------------|---------------------------------|
|  | Coaxial tip Resistor (82 Ω blue) Solder attach to components, traces, pads, or VIAs. | 0.9 pF | 1.5 Gb/s |
|  | 3-pin header | 1.0 pF | 1.5 Gb/s |
|  | Socket adapter | 1.1 pF | 1.5 Gb/s |
|  | Damped wire Solder attach to components, traces, pads, or VIAs. | 1.3 pF | 1.5 Gb/s |

Probing Solutions for 90-pin Logic Analyzers

General-Purpose Probing

Recommended probe configurations

For the best performance, use the following configurations. The configurations are listed in the recommended order.

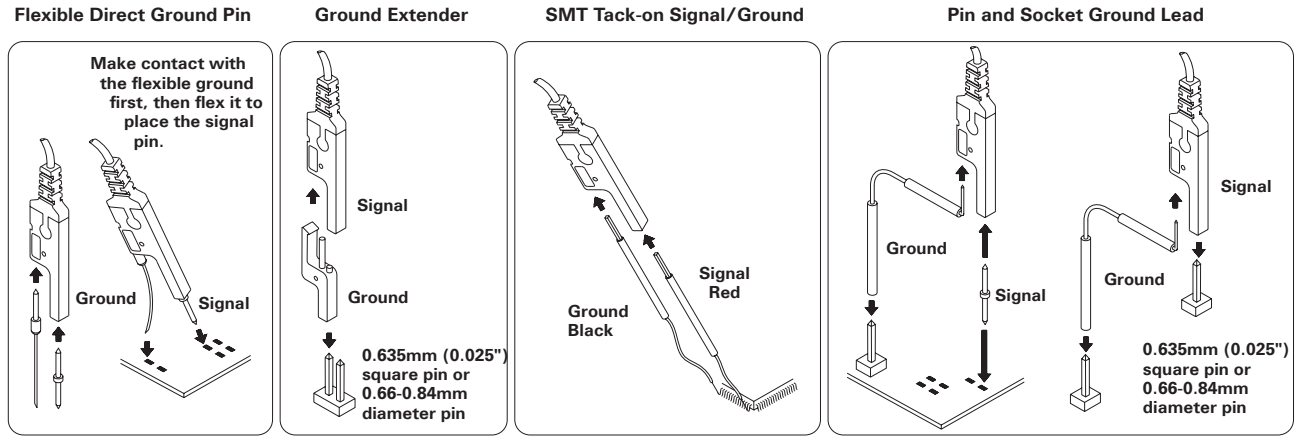

Figure 5.6. Probing configurations that give the best signal fidelity

Probing Solutions for 90-pin Logic Analyzers

Soft Touch Connectorless Probing

Seven options are available for connecting Agilent logic analyzers with 90-pin pod connectors to a target system using mass connections.

Agilent Pro Series soft touch connectorless logic analyzer probes

Agilent has developed connectorless logic analyzer probes based on soft touch probing technology. Connectorless logic analyzer probing removes the connector that is traditionally attached to the target board and replaces it with an array of probe pads. This reduces the probe load on the target by eliminating the loading associated with the physical body of the connector. Additionally,

this streamlines the design flow by eliminating the need to assign a logic analyzer connector to the bill of material of your board, procuring those connectors and then having them loaded onto your board.

Agilent's soft touch connectorless probes use micro spring-pin technology to provide reliable contact which is not dependent on the planarity of the PC board or the plating processes used to fabricate the board. No special cleaning processes are required when using Agilent's soft touch probes.

The new Agilent Pro Series soft touch connectorless probes offer a 30% smaller footprint than the original soft

touch probes and are the basis for the industry standard connectorless probing footprint.

The probes use a retention module that ensures soft touch pin-to-PC board pad alignment and holds the probe in place while in use. The Pro Series soft touch uses a "top-side" mountable retention module. The retention module is mounted on the same side of the board as the probing footprint so there is no need to access the back-side of the board. Because there is no requirement for the retention module pins to extend beyond the back-side of the board, the retention module is compatible with virtually any board thickness.

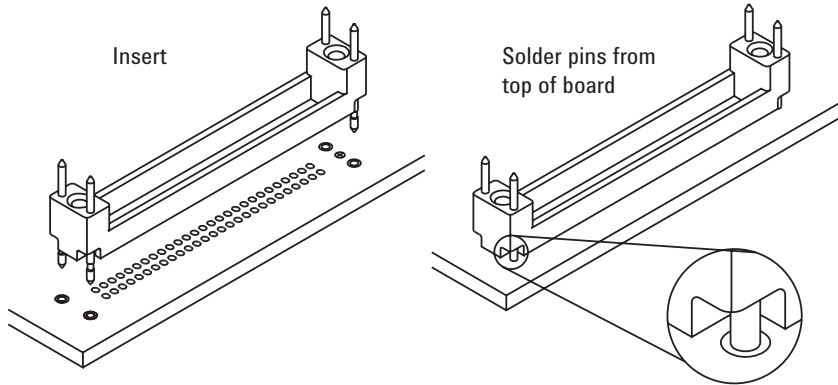

Figure 6.1. "Top-side" mountable retention module

Probing Solutions for 90-pin Logic Analyzers

Soft Touch Connectorless Probing

E5405A Differential Pro series soft touch connectorless probe

The E5405A is a 17-channel differential Pro Series soft touch connectorless probe compatible with all Agilent logic analyzers that have a 90-pin pod connector. It is capable of acquiring data at the maximum rates of the logic analyzer it is connected to.

Features

- No connector on the target board
- Top-side retention module
- Industry-standard connectorless footprint
- 17 channels, differential or single-ended clock and data
- Extremely low, < 0.7 pF, equivalent load capacitance
- Capable of data rates > 2.5 Gb/s (maximum rate dependent on analyzer used)
- 200 mV $V_{max}-V_{min}$ minimum signal amplitude
- Robust and reliable soft touch technology

Unused clock inputs can be used as data inputs.

The E5405A uses the same retention module as the E5404A and E5406A Pro Series soft touch connectorless probe.

A kit of five retention modules is shipped with each Pro Series soft touch probe. Additional kits can be ordered using Agilent part number E5403A.

E5406A/E5402A Pro Series soft touch connectorless probes

The E53406A/E5402A are 34-channel single-ended Pro Series soft touch connectorless probe compatible with all Agilent logic analyzers that have a 90-pin pod connector. The E5402A is a low profile right angle version of the E5406A probe.

Features

- No connector on the target board
- Top-side mount retention module
- Industry-standard connectorless footprint
- 34 channels, single-ended or differential clock and single-ended data
- Extremely low, < 0.7 pF, equivalent load capacitance
- Capable of data rates > 2.5 Gb/s (maximum rate dependent on analyzer used)
- 250 mV p-p minimum signal amplitude
- Robust and reliable soft touch technology

Unused clock inputs can be used as data inputs.

The E5406A (used with logic analyzers with a 90-pin cable connector) uses the same footprint, pinout, and retention module as the E5404A and E5402A Pro Series soft touch connectorless probes (used with logic analyzers with a 40-pin cable connector).

A kit of five retention modules is shipped with each Pro Series soft touch probe. Additional kits can be ordered using Agilent part number E5403A. The low profile E5402A probe uses retention module Agilent part number E5412A.

E5387A Differential soft touch connectorless probe

The E5387A is a 17-channel differential soft touch connectorless probe compatible with all Agilent logic analyzers that have a 90-pin pod connector. It is capable of acquiring data at the maximum rates of the logic analyzer it is connected to. The probe has the following inputs:

- 16 differential or single-ended data inputs
- One differential or single-ended clock input
- < 0.7 pF input capacitance
- 200 mV $V_{max}-V_{min}$ minimum signal amplitude

Unused clock inputs can be used as data inputs.

The E5387A uses the same retention module as the E5390A and E5394A soft touch probes.

A kit of five retention modules is shipped with each soft touch probe. Additional kits can be ordered using Agilent part number E5387-68701.

Probing Solutions for 90-pin Logic Analyzers

Soft Touch Connectorless Probing

E5390A single-ended soft touch connectorless probe

The E5390A is a 34-channel single-ended soft touch connectorless probe compatible with all Agilent logic analyzers that have a 90-pin pod connector. It is capable of acquiring data at the maximum rates of the logic analyzer it is connected to. The probe has the following inputs:

- 32 single-ended data inputs
- Two differential or single-ended clock inputs
- < 0.7 pf input capacitance
- 250 mV p-p minimum signal amplitude

Unused clock inputs can be used as data inputs.

The E5390A (used with logic analyzers with a 90-pin pod connector) uses the same footprint, pinout and retention module as the E5394A single-ended soft touch connectorless probe (used with logic analyzers with a 40-pin pod connector).

A kit of five retention modules is shipped with each soft touch probe. Additional kits can be ordered using Agilent part number E5387-68701.

E5398A half-size soft touch connectorless probe

The E5398A is a small space saving probe compatible with all Agilent logic analyzers that have a 90-pin cable connector. It is a 17-channel, single-ended probe capable of capturing data at the maximum rates of the logic analyzer it is connected to. The probe has the following inputs:

- 16 single-ended data inputs
- One differential or single-ended clock input
- < 0.7 pf equivalent load capacitance
- 250 mV p-p minimum signal amplitude

Unused clock inputs can be used as data inputs.

The E5398A (used with logic analyzers with a 90-pin cable connector) uses the same footprint, pinout, and retention module as the E5396A single-ended soft touch connectorless probe (used with logic analyzers with a 40-pin cable connector).

More information about soft touch connectorless probes is available on the web at www.agilent.com/find/softtouch

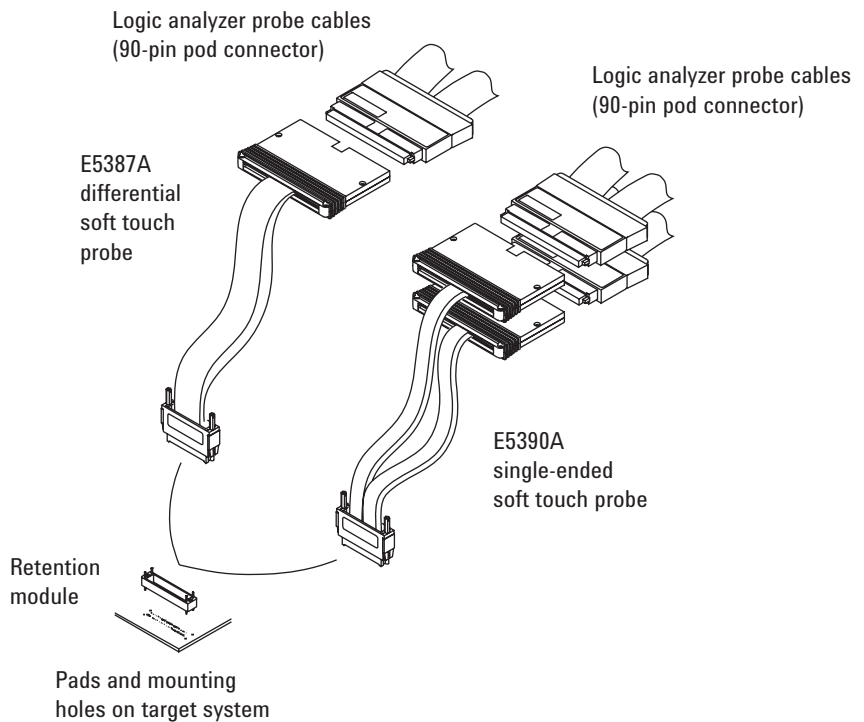

Figure 6.2. Soft touch probes

Probing Solutions for 90-pin Logic Analyzers

Soft Touch Connectorless Probing

Probe dimensions

The following figures show dimensions, footprint, and pinout information you will need to design your target system board for use with the Agilent soft touch probes.

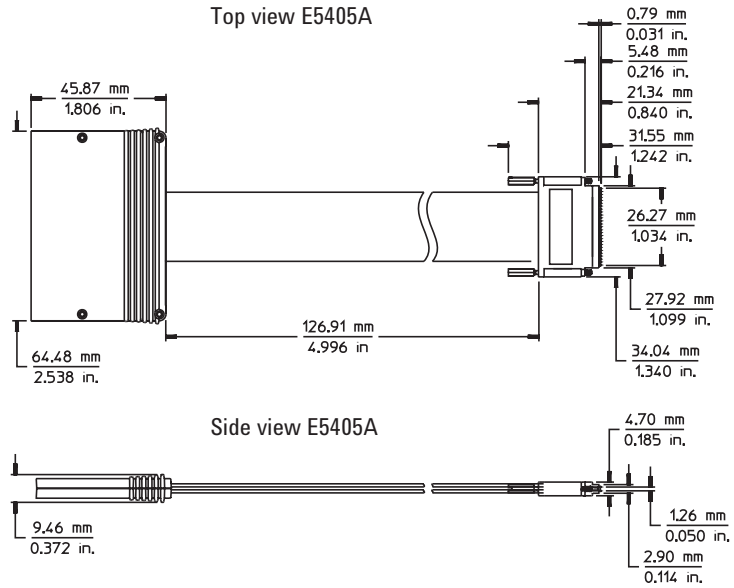

Figure 6.3. E5405A probe dimensions

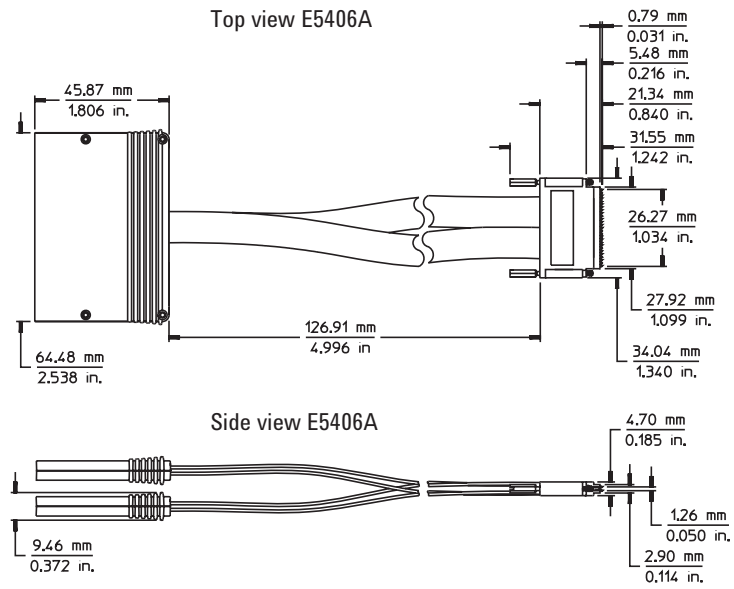

Figure 6.4. E5406A probe dimensions

Probing Solutions for 90-pin Logic Analyzers

Soft Touch Connectorless Probing

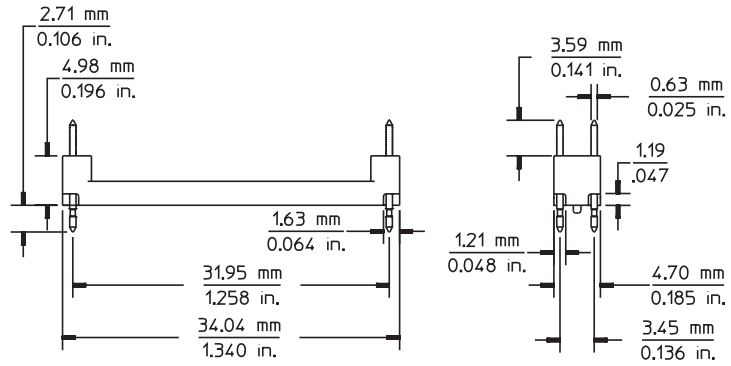

Figure 6.5. Pro Series soft touch retention module dimensions, part number E5403A

Pro Series soft touch retention module dimensions

The following dimensions show the soft touch probe attached to the retention module. The retention module is mounted on the PC board.

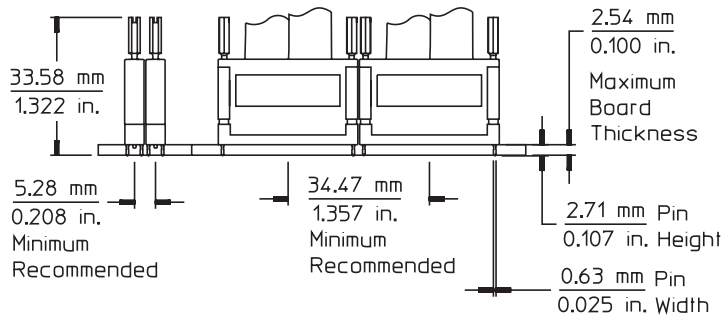

Figure 6.6. Pro Series soft touch side-by-side dimensions with retention module, part number E5403A

Probing Solutions for 90-pin Logic Analyzers

Soft Touch Connectorless Probing

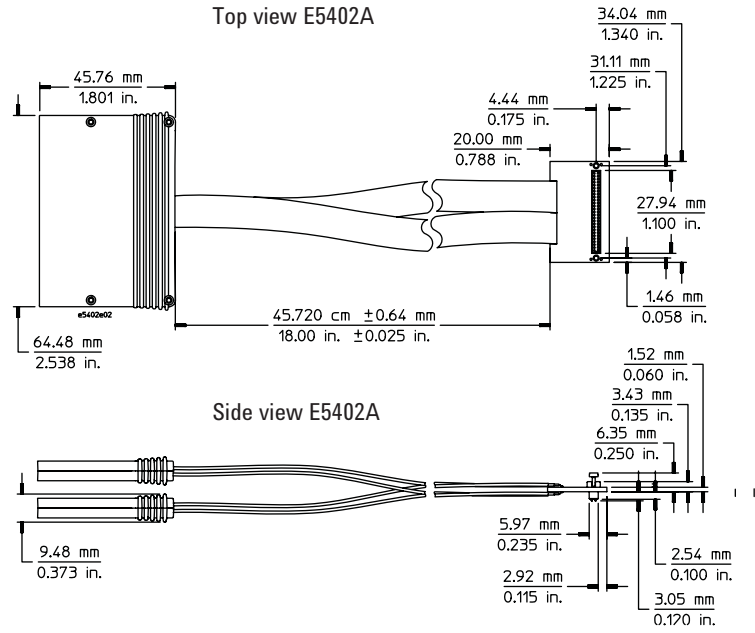

Figure 6.7. E5402A probe dimensions

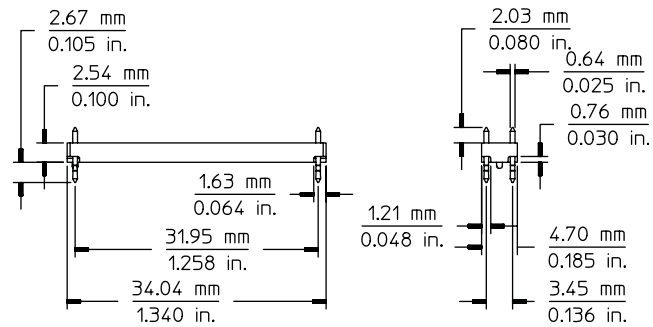

Figure 6.8. E5412A retention module dimensions

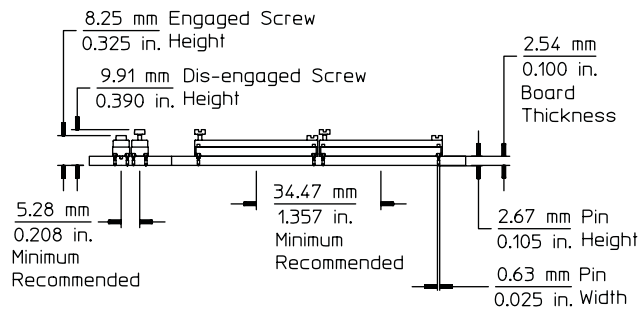

Figure 6.9. E5412A side-by-side dimensions

Probing Solutions for 90-pin Logic Analyzers

Soft Touch Connectorless Probing

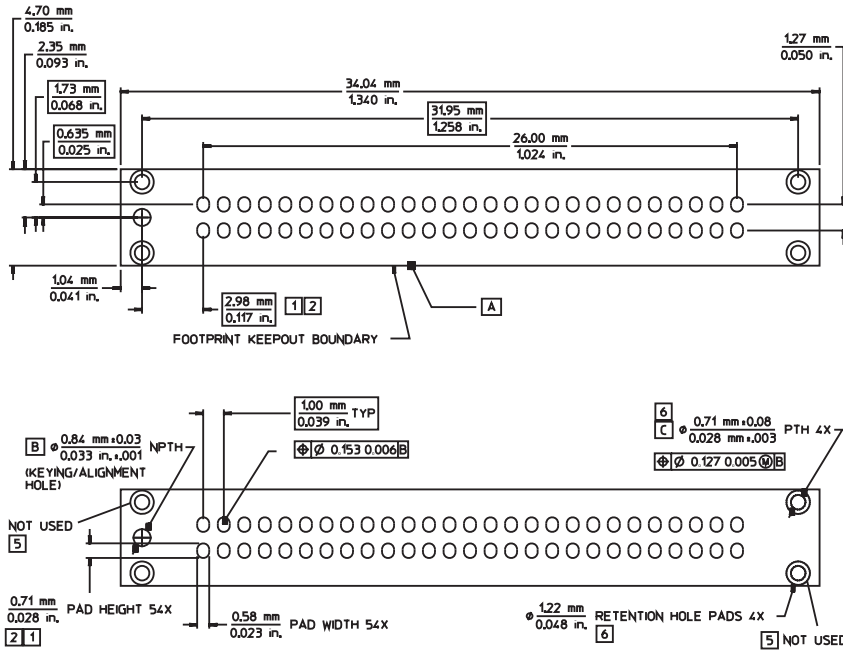
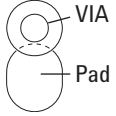

Figure 6.10. Pro Series soft touch footprint dimensions (see drawing notes)

Drawing notes:

- 1 Maintain a solder mask web between pads when traces are routed between the pads on the same layer. The solder mask may not encroach onto the pads within the pad dimension shown.
- 2 VIAs not allowed on these pads. VIA edges may be tangent to pad edges as long as a solder mask web between VIAs and pads is maintained. 
- 3 Surface finishes on pads should be HASL immersion silver, or gold over nickel.
- 4 This footprint is compatible with retention module Agilent part number E5405-68702.
- 5 This through hole is not used with the Agilent retention module.
- 6 Plated through hole should not be tied to ground plane for thermal relief.

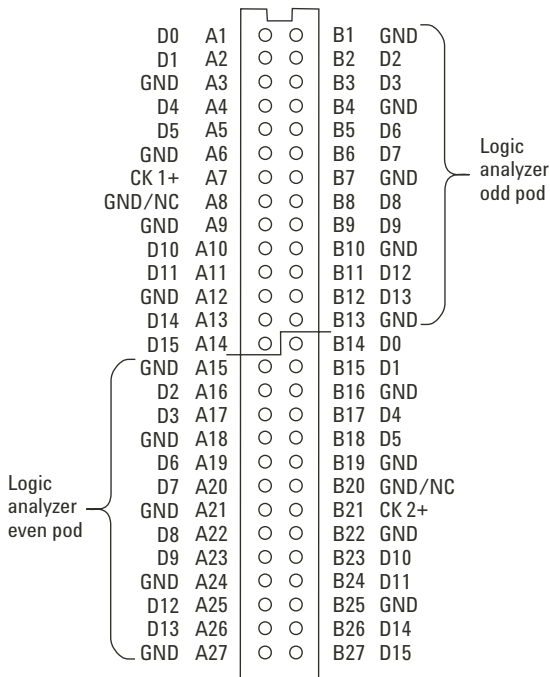

Figure 6.11. Pad numbers for E5404/06A 34-channel single-ended probes

Probing Solutions for 90-pin Logic Analyzers

Soft Touch Connectorless Probing

| E5404/06A 34-channel single-ended probe | | | | Logic analyzer |
|---|-------|---------|-----|--|
| Signal name | Pad # | Channel | Pod | |
| D0 | A1 | → 0 | | Whichever pod is connected to "Odd" on the E5404/06A probe |
| D1 | A2 | → 1 | | |
| Ground | A3 | | | |
| D4 | A4 | → 4 | | |
| D5 | A5 | → 5 | | |
| Ground | A6 | | | |
| Clock 1+ | A7 | → Clock | | |
| GND/NC/Clock 1- | A8 | | | |
| Ground | A9 | | | |
| D10 | A10 | → 10 | | |
| D11 | A11 | → 11 | | |
| Ground | A12 | | | |
| D14 | A13 | → 14 | | |
| D15 | A14 | → 15 | | |
| Ground | A15 | | | |
| D2 | A16 | → 2 | | |
| D3 | A17 | → 3 | | |
| Ground | A18 | | | |
| D6 | A19 | → 6 | | |
| D7 | A20 | → 7 | | |
| Ground | A21 | | | |
| D8 | A22 | → 8 | | |
| D9 | A23 | → 9 | | |
| Ground | A24 | | | |
| D12 | A25 | → 12 | | |
| D13 | A26 | → 13 | | |
| Ground | A27 | | | |

| E5404/06A 34-channel single-ended probe | | | | Logic analyzer | |
|---|-------|---------|-----|--|---|
| Signal name | Pad # | Channel | Pod | | |
| Ground | B1 | | | Whichever pod is connected to "Odd" on the E5404/06A probe | |
| D2 | B2 | → 2 | | | |
| D3 | B3 | → 3 | | | |
| Ground | B4 | | | | |
| D6 | B5 | → 6 | | | |
| D7 | B6 | → 7 | | | |
| Ground | B7 | | | | |
| D8 | B8 | → 8 | | | |
| D9 | B9 | → 9 | | | |
| Ground | B10 | | | | |
| D12 | B11 | → 12 | | | |
| D13 | B12 | → 13 | | | |
| Ground | B13 | | | | |
| D0 | B14 | → 0 | | | Whichever pod is connected to "Even" on the E5404/06A probe |
| D1 | B15 | → 1 | | | |
| Ground | B16 | | | | |
| D4 | B17 | → 4 | | | |
| D5 | B18 | → 5 | | | |
| Ground | B19 | | | | |
| GND/NC/Clock 2- | B20 | | | | |
| Clock 2+ | B21 | → Clock | | | |
| Ground | B22 | | | | |
| D10 | B23 | → 10 | | | |
| D11 | B24 | → 11 | | | |
| Ground | B25 | | | | |
| D14 | B26 | → 14 | | | |
| D15 | B27 | → 15 | | | |

Probing Solutions for 90-pin Logic Analyzers

Soft Touch Connectorless Probing

| | | | | | |
|------|-----|---|---|-----|------|
| D0+ | A1 | ○ | ○ | B1 | GND |
| D0- | A2 | ○ | ○ | B2 | D1- |
| GND | A3 | ○ | ○ | B3 | D1+ |
| D2+ | A4 | ○ | ○ | B4 | GND |
| D2- | A5 | ○ | ○ | B5 | D3- |
| GND | A6 | ○ | ○ | B6 | D3+ |
| D4+ | A7 | ○ | ○ | B7 | GND |
| D4- | A8 | ○ | ○ | B8 | D5- |
| GND | A9 | ○ | ○ | B9 | D5+ |
| D6+ | A10 | ○ | ○ | B10 | GND |
| D6- | A11 | ○ | ○ | B11 | D7- |
| GND | A12 | ○ | ○ | B12 | D7+ |
| NC | A13 | ○ | ○ | B13 | GND |
| NC | A14 | ○ | ○ | B14 | CLK- |
| GND | A15 | ○ | ○ | B15 | CLK+ |
| D8+ | A16 | ○ | ○ | B16 | GND |
| D8- | A17 | ○ | ○ | B17 | D9- |
| GND | A18 | ○ | ○ | B18 | G9+ |
| D10+ | A19 | ○ | ○ | B19 | GND |
| D10- | A20 | ○ | ○ | B20 | D11- |
| GND | A21 | ○ | ○ | B21 | D11+ |
| D12+ | A22 | ○ | ○ | B22 | GND |
| D12- | A23 | ○ | ○ | B23 | D13- |
| GND | A24 | ○ | ○ | B24 | E13+ |
| D14+ | A25 | ○ | ○ | B25 | GND |
| D14- | A26 | ○ | ○ | B26 | D15- |
| GND | A27 | ○ | ○ | B27 | D15+ |

Figure 6.12. Pad numbers for E5405A 17-bit differential probe

Probing Solutions for 90-pin Logic Analyzers

Soft Touch Connectorless Probing

| E5405A differential probe | | Logic analyzer | |
|---------------------------|-------|----------------|--|
| Signal name | Pad # | Channel | Pod |
| D0 (+) | A1 | → 0 | Whichever pod is plugged into the E5405A probe |
| D0 (-) | A2 | | |
| Ground | A3 | | |
| D2 (+) | A4 | → 2 | |
| D2 (-) | A5 | | |
| Ground | A6 | | |
| D4 (+) | A7 | → 4 | |
| D4 (-) | A8 | | |
| Ground | A9 | | |
| D6 (+) | A10 | → 6 | |
| D6 (-) | A11 | | |
| Ground | A12 | | |
| NC | A13 | | |
| NC | A14 | | |
| Ground | A15 | | |
| D8 (+) | A16 | → 8 | |
| D8 (-) | A17 | | |
| Ground | A18 | | |
| D10 (+) | A19 | → 10 | |
| D10 (-) | A20 | | |
| Ground | A21 | | |
| D12 (+) | A22 | → 12 | |
| D12 (-) | A23 | | |
| Ground | A24 | | |
| D14 (+) | A25 | → 14 | |
| D14 (-) | A26 | | |
| Ground | A27 | | |

| E5405A differential probe | | Logic analyzer | |
|---------------------------|-------|----------------|--|
| Signal name | Pad # | Channel | Pod |
| Ground | B1 | | Whichever pod is plugged into the E5405A probe |
| D1 (-) | B2 | | |
| D1 (+) | B3 | → 1 | |
| Ground | B4 | | |
| D3 (-) | B5 | | |
| D3 (+) | B6 | → 3 | |
| Ground | B7 | | |
| D5 (-) | B8 | | |
| D5 (+) | B9 | → 5 | |
| Ground | B10 | | |
| D7 (-) | B11 | | |
| D7 (+) | B12 | → 7 | |
| Ground | B13 | | |
| Clock- | B14 | | |
| Clock+ | B15 | → Clock | |
| Ground | B16 | | |
| D9 (-) | B17 | | |
| D9 (+) | B18 | → 9 | |
| Ground | B19 | | |
| D11 (-) | B20 | | |
| D11 (+) | B21 | → 11 | |
| Ground | B22 | | |
| D13 (-) | B23 | | |
| D13 (+) | B24 | → 13 | |
| Ground | B25 | | |
| D15 (-) | B26 | | |
| D15 (+) | B27 | → 15 | |

Probing Solutions for 90-pin Logic Analyzers

Soft Touch Connectorless Probing

Probe dimensions

The following figures show dimensions, footprint, and pinout information you will need to design your target system board for use with the Agilent soft touch probes.

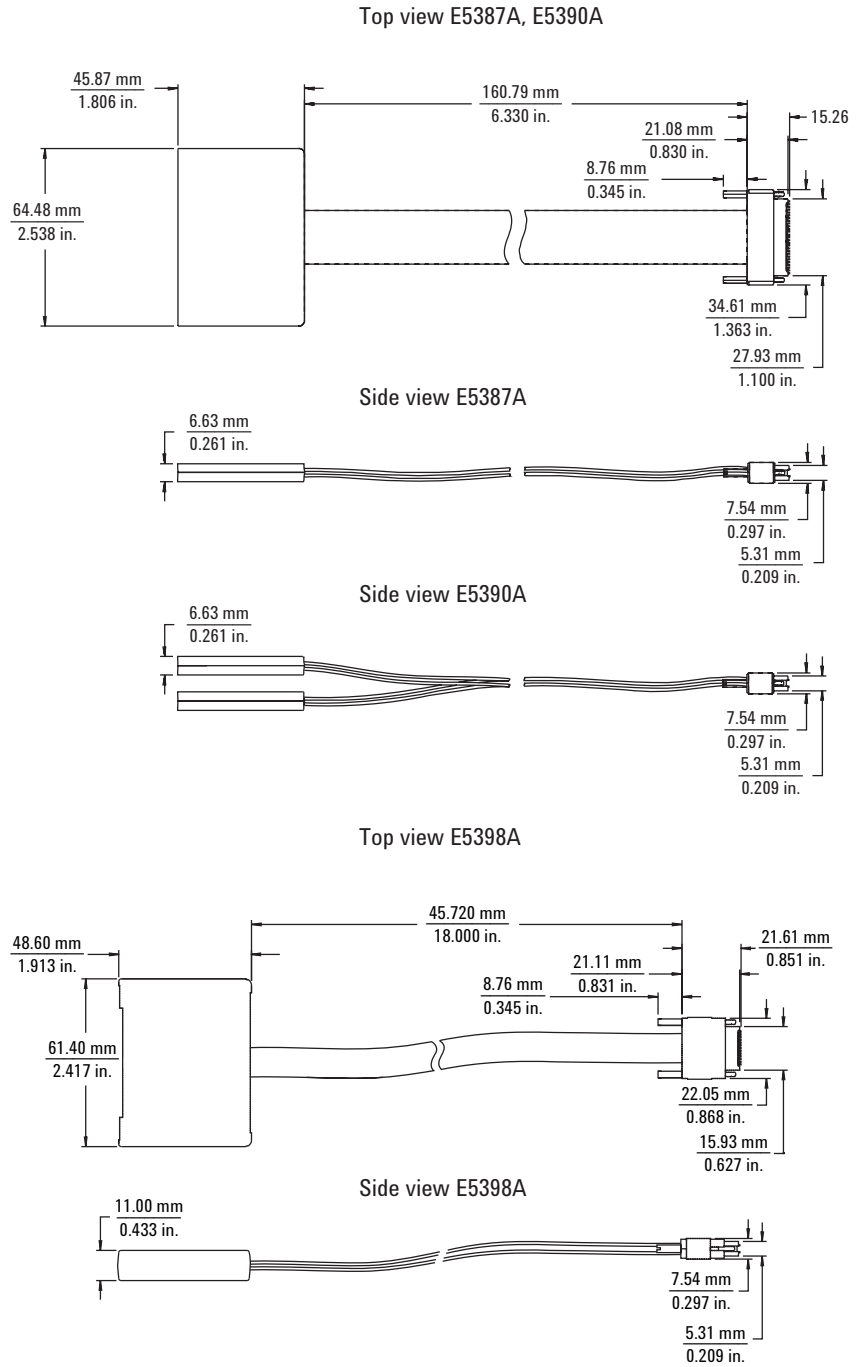

Figure 6.13. Probe dimensions

Probing Solutions for 90-pin Logic Analyzers

Soft Touch Connectorless Probing

Retention module dimensions

The soft touch probes are attached to the PC board using a retention module which ensures pin-to-pad alignment and holds the probe in place. A board thickness of up to 2.54 mm (0.100 inch) is recommended. Insert the retention module into the board, noting the keying pin, and solder the four alignment pins to the backside of the board.

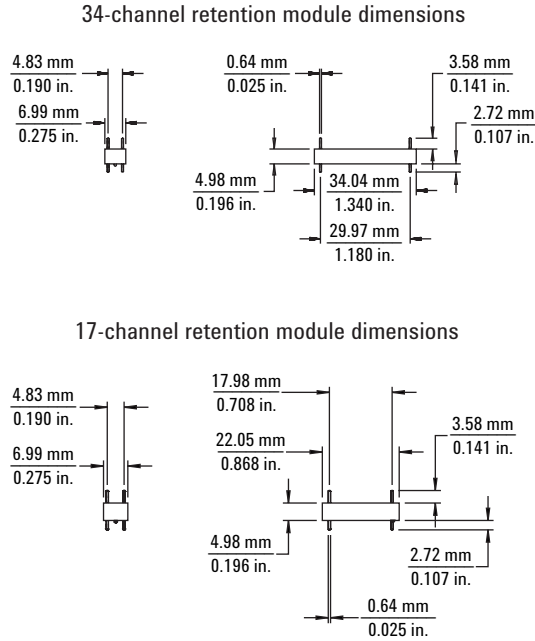

Figure 6.14. Retention module dimensions

Probe and retention module dimensions

The following dimensions show the soft touch probe attached to the retention module. The retention module is mounted on the PC board.

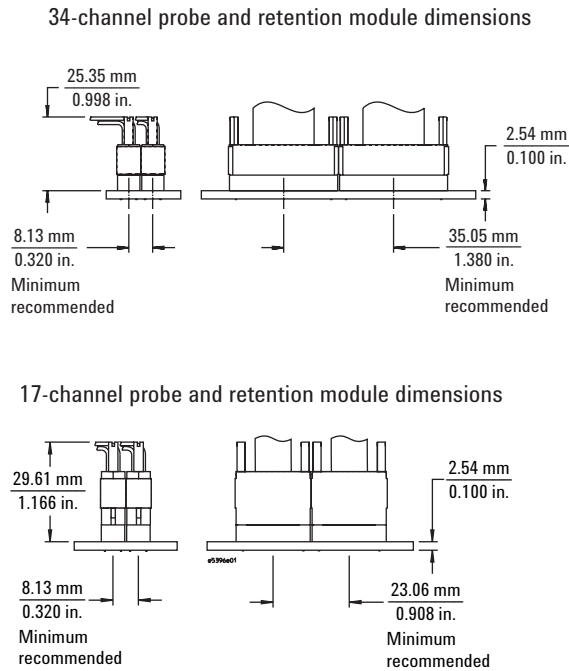

Figure 6.15. Probe and retention module dimensions

Probing Solutions for 90-pin Logic Analyzers

Soft Touch Connectorless Probing

Probe footprint dimensions

Use these probe footprint dimensions for the PC board pads and holes for attaching the retention module.

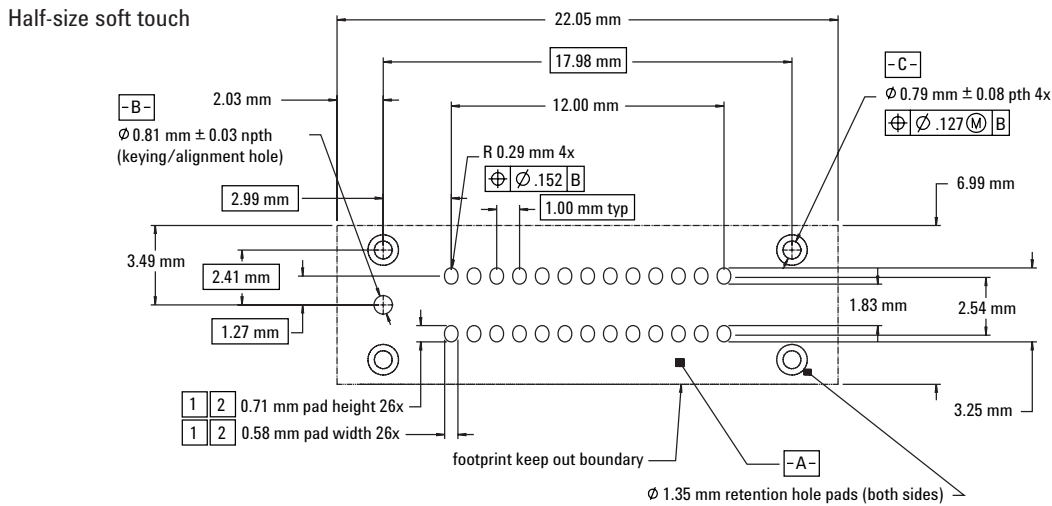
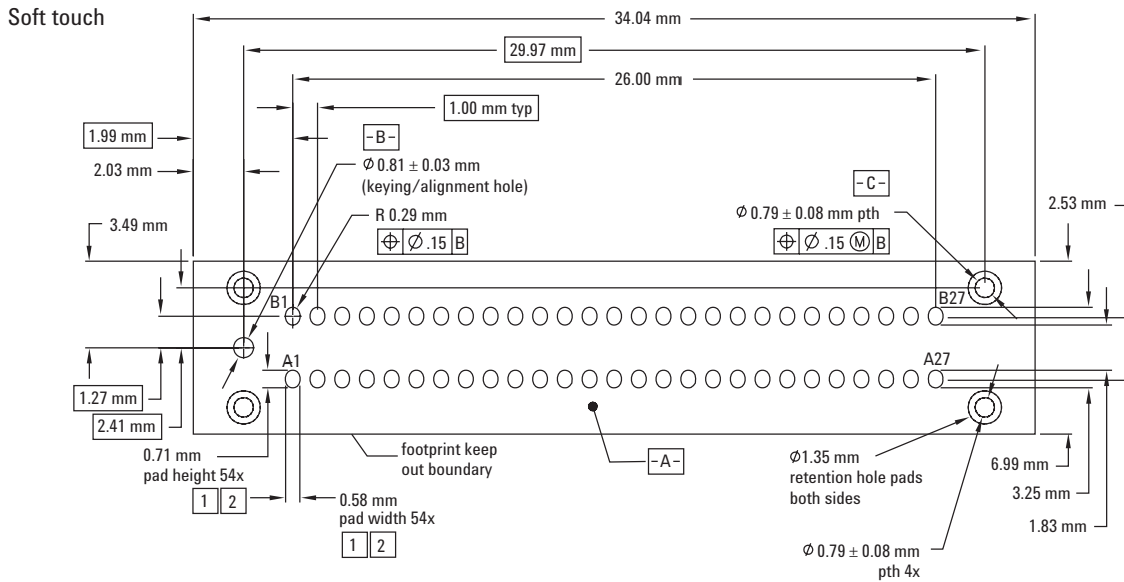

1. Must maintain a solder mask web between pads when traces are routed between the pads on the same layer. Soldermask may not encroach onto the pads within the pad dimension shown.
2. Via in pad not allowed on these pads. Via edges may be tangent to pad edges as long as a solder mask web between vias and pads is maintained.
3. Permissible surface finishes on pads are HASL, immersion silver, or gold over nickel.
4. Footprint is compatible with retention module, Agilent part # E5387-68702.
5. Retention module dimensions are 34.04 mm x 7.01 mm x 4.98 mm tall relative to the top surface of the PDB. Retention pins extend 4.32 mm beyond the bottom surface of the RM through the PCB.
6. Assume normal artwork tolerances for pad size dimensions.

Figure 6.16. Footprint dimensions

Probing Solutions for 90-pin Logic Analyzers

Soft Touch Connectorless Probing

Pinout for the E5387A differential soft touch probe

The following graphic and table show the E5387A differential soft touch probe pad numbers and logic analyzer pod inputs.

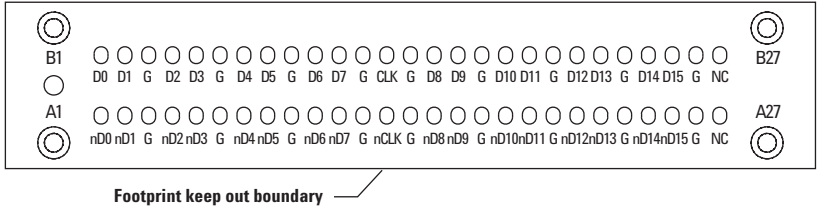

Figure 6.17. Pinout

| E5387A differential probe | | | | Logic analyzer | | |
|---------------------------|-------|------------------|-------|----------------|-----|-------|
| Negative signals | | Positive signals | | | | |
| Signal name | Pad # | Signal name | Pad # | Channel | Pod | |
| D0 (-) | A1 | D0 (+) | B1 | → | 0 | |
| D1 (-) | A2 | D1 (+) | B2 | → | | |
| Ground | A3 | Ground | B3 | | | |
| D2 (-) | A4 | D2 (+) | B4 | → | | |
| D3 (-) | A5 | D3 (+) | B5 | → | | |
| Ground | A6 | Ground | B6 | | | |
| D4 (-) | A7 | D4 (+) | B7 | → | | |
| D5 (-) | A8 | D5 (+) | B8 | → | | |
| Ground | A9 | Ground | B9 | | | |
| D6 (-) | A10 | D6 (+) | B10 | → | | |
| D7 (-) | A11 | D7 (+) | B11 | → | | |
| Ground | A12 | Ground | B12 | | | |
| Clock (-) | A13 | Clock (+) | B13 | → | | Clock |
| Ground | A14 | Ground | B14 | | | |
| D8 (-) | A15 | D8 (+) | B15 | → | | 8 |
| D9 (-) | A16 | D9 (+) | B16 | → | 9 | |
| Ground | A17 | Ground | B17 | | | |
| D10 (-) | A18 | D10 (+) | B18 | → | 10 | |
| D11 (-) | A19 | D11 (+) | B19 | → | 11 | |
| Ground | A20 | Ground | B20 | | | |
| D12 (-) | A21 | D12 (+) | B21 | → | 12 | |
| D13 (-) | A22 | D13 (+) | B22 | → | 13 | |
| Ground | A23 | Ground | B23 | | | |
| D14 (-) | A24 | D14 (+) | B24 | → | 14 | |
| D15 (-) | A25 | D15 (+) | B25 | → | 15 | |
| Ground | A26 | Ground | B26 | | | |
| N/C | A27 | N/C | B27 | | | |

Probing Solutions for 90-pin Logic Analyzers

Soft Touch Connectorless Probing

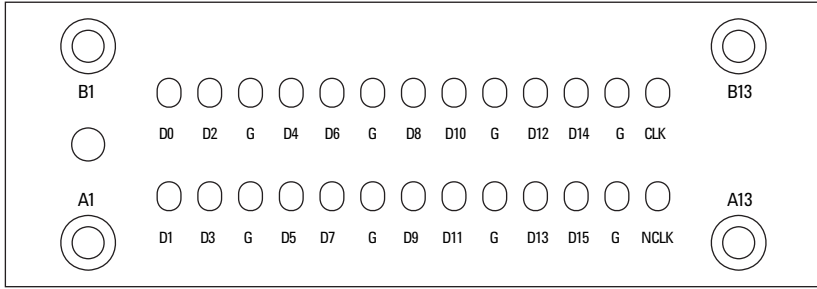

Figure 6.18. Pinout

| E5398A 17-channel single-ended probe | | Logic analyzer | |
|--------------------------------------|-------|----------------|--|
| Signal name | Pad # | Channel | Pod |
| D1 | A1 | → 1 | Whichever pod is plugged into the E5398A probe |
| D3 | A2 | → 3 | |
| Ground | A3 | | |
| D5 | A4 | → 5 | |
| D7 | A5 | → 7 | |
| Ground | A6 | | |
| D9 | A7 | → 9 | |
| D11 | A8 | → 11 | |
| Ground | A9 | | |
| D13 | A10 | → 13 | |
| D15 | A11 | → 15 | |
| Ground | A12 | | |
| Clock (-) | A13 | → n/a | |

| E5398A 17-channel single-ended probe | | Logic analyzer | |
|--------------------------------------|-------|----------------|--|
| Signal name | Pad # | Channel | Pod |
| D0 | B1 | → 0 | Whichever pod is plugged into the E5398A probe |
| D2 | B2 | → 2 | |
| Ground | B3 | | |
| D4 | B4 | → 4 | |
| D6 | B5 | → 6 | |
| Ground | B6 | | |
| D8 | B7 | → 8 | |
| D10 | B8 | → 10 | |
| Ground | B9 | | |
| D12 | B10 | → 12 | |
| D14 | B11 | → 14 | |
| Ground | B12 | | |
| Clock (+) | B13 | → n/a | |

Probing Solutions for 90-pin Logic Analyzers

Soft Touch Connectorless Probing

Pinout for the E5390A single-ended soft touch probe

The following graphic and table show the E5390A single-ended soft touch probe pad numbers and logic analyzer pod inputs.

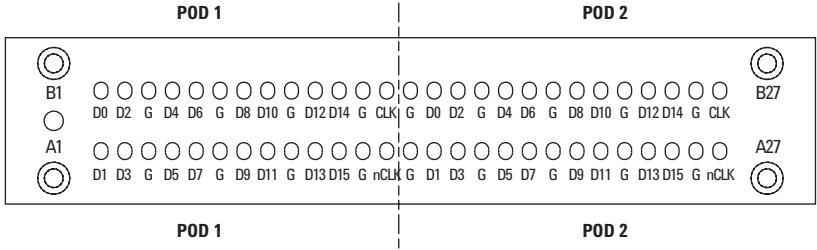

Figure 6.19. Pinout

| E5390A single-ended probe | | Logic analyzer | |
|---------------------------|-------|----------------|---|
| Signal name | Pad # | Channel | Pod |
| D1 | A1 | → 1 | Whichever pod is connected to "Odd" on the E5390A probe |
| D3 | A2 | → 3 | |
| Ground | A3 | | |
| D5 | A4 | → 5 | |
| D7 | A5 | → 7 | |
| Ground | A6 | | |
| D9 | A7 | → 9 | |
| D11 | A8 | → 11 | |
| Ground | A9 | | |
| D13 | A10 | → 13 | |
| D15 | A11 | → 15 | |
| Ground | A12 | | |
| Clock (-) | A13 | → Clock | |
| D0 | B1 | → 0 | |
| D2 | B2 | → 2 | |
| Ground | B3 | | |
| D4 | B4 | → 4 | |
| D6 | B5 | → 6 | |
| Ground | B6 | | |
| D8 | B7 | → 8 | |
| D10 | B8 | → 10 | |
| Ground | B9 | | |
| D12 | B10 | → 12 | |
| D14 | B11 | → 14 | |
| Ground | B12 | | |
| Clock (+) | B13 | → Clock | |

| E5390A single-ended probe | | Logic analyzer | |
|---------------------------|-------|----------------|--|
| Signal name | Pad # | Channel | Pod |
| Ground | A14 | | Whichever pod is connected to "Even" on the E5390A probe |
| D1 | A15 | → 1 | |
| D3 | A16 | → 3 | |
| Ground | A17 | | |
| D5 | A18 | → 5 | |
| D7 | A19 | → 7 | |
| Ground | A20 | | |
| D9 | A21 | → 9 | |
| D11 | A22 | → 11 | |
| Ground | A23 | | |
| D13 | A24 | → 13 | |
| D15 | A25 | → 15 | |
| Ground | A26 | | |
| Clock (-) | A27 | → Clock | |
| Ground | B14 | | |
| D0 | B15 | → 0 | |
| D2 | B16 | → 2 | |
| Ground | B17 | | |
| D4 | B18 | → 4 | |
| D6 | B19 | → 6 | |
| Ground | B20 | | |
| D8 | B21 | → 8 | |
| D10 | B22 | → 10 | |
| Ground | B23 | | |
| D12 | B24 | → 12 | |
| D14 | B25 | → 14 | |
| Ground | B26 | | |
| Clock (+) | B27 | → Clock | |

Probing Solutions for 90-pin Logic Analyzers

Soft Touch Connectorless Probing

Equivalent probe loads

The following probe load models are based on in-circuit measurements made with an Agilent 8753E 6 GHz network analyzer and an Agilent 54750A TDR/TDT using a 50 Ω test fixture. The following schematic accurately models the probe load out to 6 GHz. PC board pads are not included.

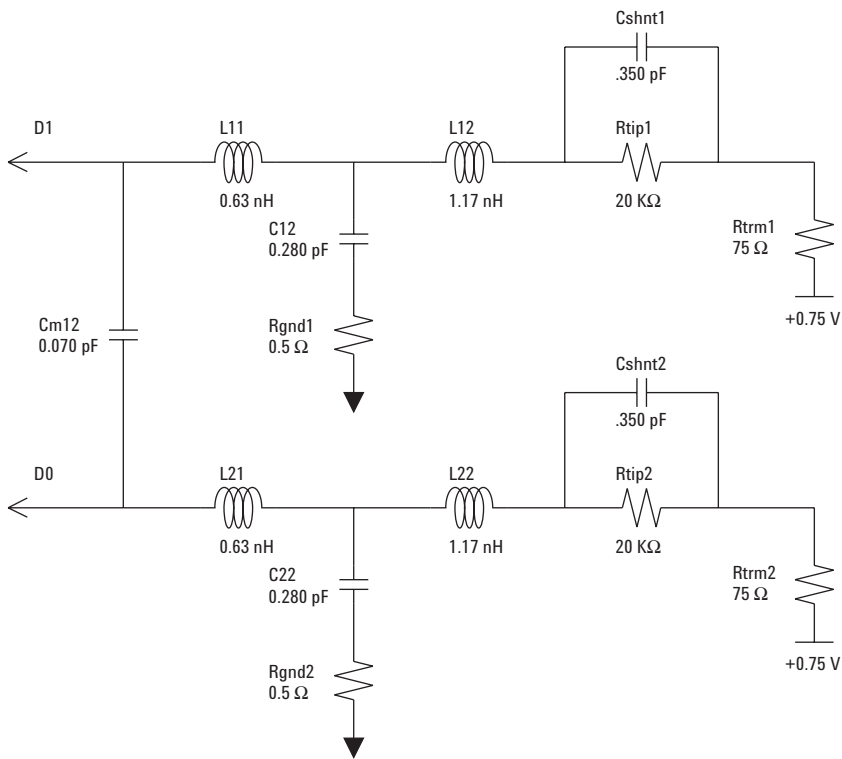

Figure 6.20. Equivalent probe load model

Probing Solutions for 90-pin Logic Analyzers

Mictor and Samtec Probing

E5378A 100-pin single-ended probe

The E5378A is a 34-channel single-ended Samtec probe capable of capturing data up to 1.5 Gbits/sec (see Figures 7.3 and 7.5 for probe dimensions and equivalent load). The probe has the following inputs:

- 32 single-ended data inputs, in two groups (pods) of 16.
- Two differential clock inputs. Either or both clock inputs can be acquired as data inputs if not used as a clock.
- Two data threshold reference inputs, one for each pod (group of 16 data inputs).

E5379A 100-pin differential probe

The E5379A is a 17-channel differential Samtec probe capable of capturing data up to 1.5 Gbits/sec (see Figures 7.5 and 7.6 for probe dimensions and equivalent load). The probe has the following inputs:

- 16 differential data inputs.
- One differential clock input.
- The clock input can be acquired as a data input if it is not used as a clock.

Refer to Table 8 on page 60 for part numbers for mating connectors and shrouds.

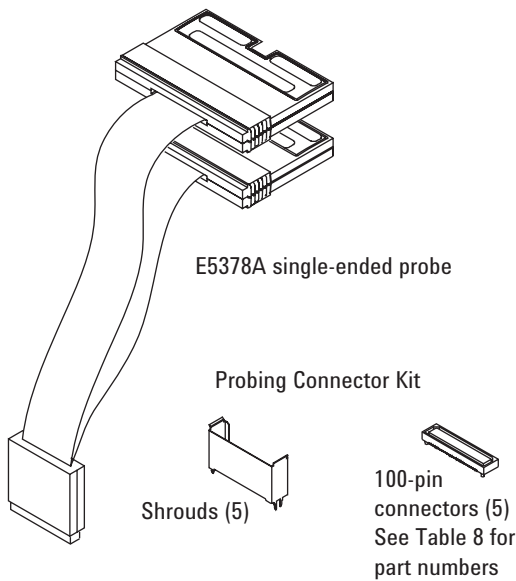

Figure 6.21. Agilent E5378A probe

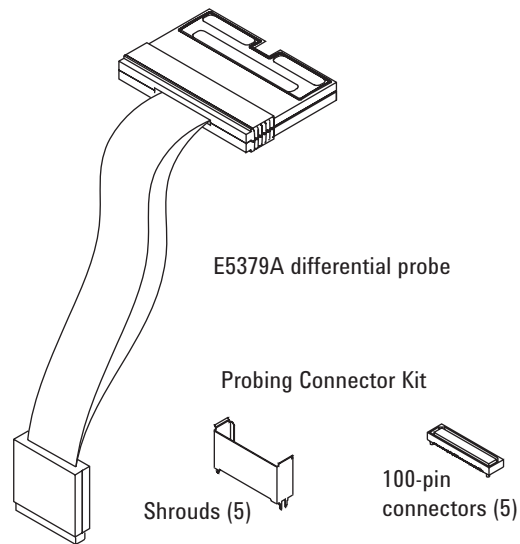

Figure 6.22. Agilent E5379A probe

Probing Solutions for 90-pin Logic Analyzers

Mictor and Samtec Probing

E5380A 38-pin probe

The E5380A is designed to be compatible with the Mictor connector. If you have a target system designed for connection to the E5346A high-density probe adapter, the E5380A probe will connect directly to this same Mictor connector. (For information on the E5346A, refer to pages 24 - 25). The maximum state speed when used with the E5380A probe is 600 Mbits/second. The minimum input signal amplitude required by the E5380A is 300 mV.

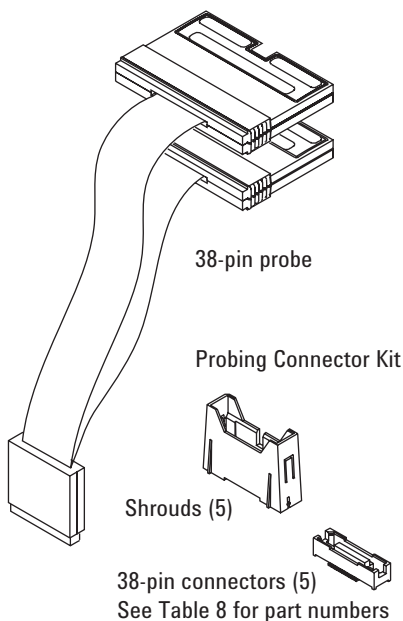

Figure 7.1. Agilent E5380A probe

The E5380A probe combines two 17-channel cables into a single-ended 38-pin Mictor connector.

Refer to Table 8 for connector, shroud, and kit part numbers.

Table 8. Mating connectors, shrouds, and kits for Agilent E5378A, E5379A, and E5380A probes

| For probe model numbers | Description | Agilent part number |
|-------------------------|--|---------------------|
| E5378A, E5379A | Kit of 5 support shrouds and 5 100-pin Samtec connectors for PC board thickness up to 1.57 mm (0.062") | 16760-68702 |
| | Kit of 5 support shrouds and 5 100-pin Samtec connectors for PC board thickness up to 3.05 mm (0.120") | 16760-68703 |
| | One 100-pin Samtec connector (also available from Samtec as part number ASP-65067-01) | 1253-3620 |
| | One support shroud for PC board thickness up to 1.57 mm (0.062") | 16760-02302 |
| | One support shroud for PC board thickness up to 3.05 mm (0.120") | 16760-02303 |
| E5380A | Kit of 5 support shrouds and 5 38-pin Mictor connectors for PC board thickness up to 1.57 mm (0.062") | E5346-68701 |
| | Kit of 5 support shrouds and 5 38-pin Mictor connectors for PC board thickness up to 3.175 mm (0.125") | E5346-68700 |
| | One 38-pin Mictor connector (also available from AMP as part number 2-767004-2) | 1252-7431 |
| | One support shroud for PC board thickness up to 1.57 mm (0.062") | E5346-44701 |
| | One support shroud for PC board thickness up to 3.175 mm (0.125") | E5346-44704 |
| | One support shroud for PC board thickness up to 4.318 mm (0.700") | E5346-44703 |

For further information on designing the E5378A, E5379A, or E5380A probe connectors into your system, refer to the following documents:

| | | |
|--|--|--|
| Agilent Technologies Logic Analyzer Probes (E5378A, E5379A, E5380A, and E5386A) User's Guide | Mechanical drawings, electrical models, general information on probes for logic analyzers with 90-pin connectors | 16760-97016 http://cp.literature.agilent.com/litweb/pdf/16760-97016.pdf |
| Designing High-Speed Digital Systems for Logic Analyzer Probing | Design recommendations, examples, and analysis for layout of target systems | 5988-2989EN http://www.agilent.com/find/probeguide |

Probing Solutions for 90-pin Logic Analyzers

Mictor and Samtec Probing

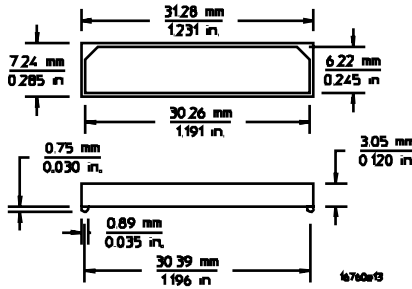

Figure 7.2. Dimensions of the 100-Pin Samtec connector used in the 16760-68702 and 16760-68703 connector kits

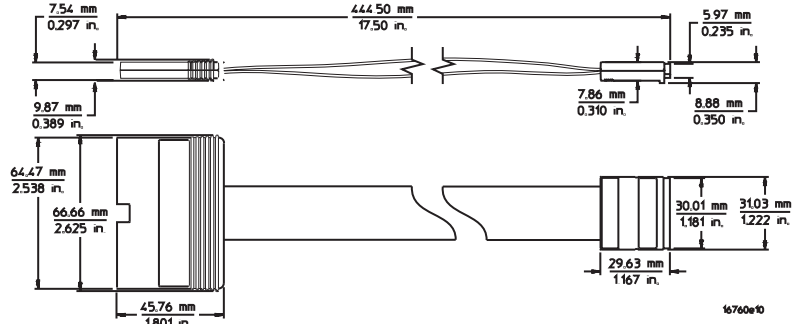

Figure 7.3. E5378A 100-pin single-ended probe dimensions

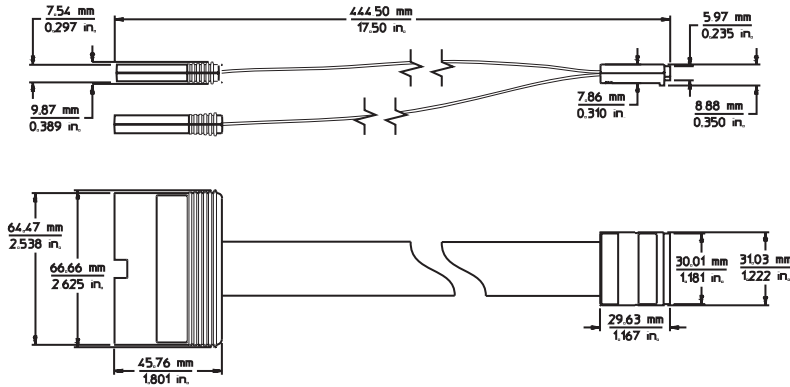

Figure 7.4. E5379A 100-pin differential probe dimensions

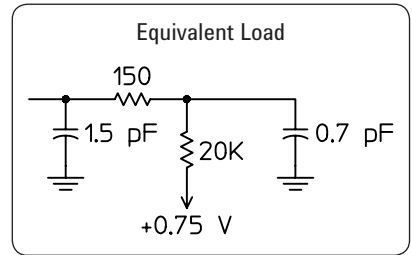

Figure 7.5. E5378A and E5379A input equivalent load, including 100-pin connector

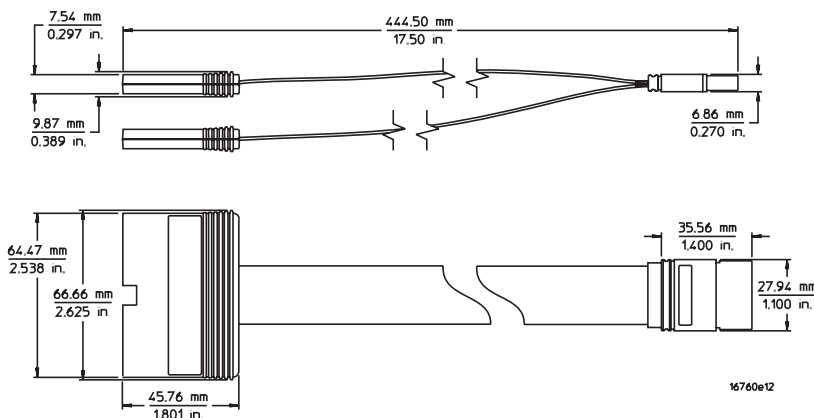

Figure 7.6. E5380A 38-Pin probe dimensions

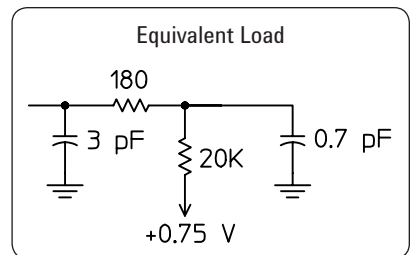

Figure 7.7. E5380A input equivalent load, including 38-pin connector

Probing Solutions for 90-pin Logic Analyzers

High-Speed Timing Probing

E5386A half-channel adapter

When the Agilent high-speed timing analyzers are operating at their maximum speed, only the even numbered channels are used. To reduce the number of probes and connectors required, the E5386A adapter maps the even channels to all of the pins of an E5378A and E5379A Samtec probes, E5387A and E5390A Soft Touch Connectorless probes, and Soft Touch Pro Series connectorless probes E5404A, E5405A, and E5406A. The following diagrams show how the E5386A is connected.

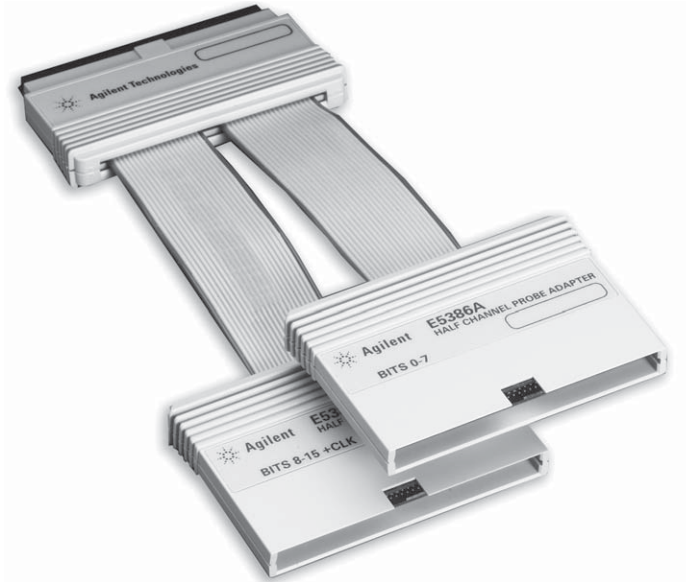

Figure 8.1. E5386A half-channel probe adapter

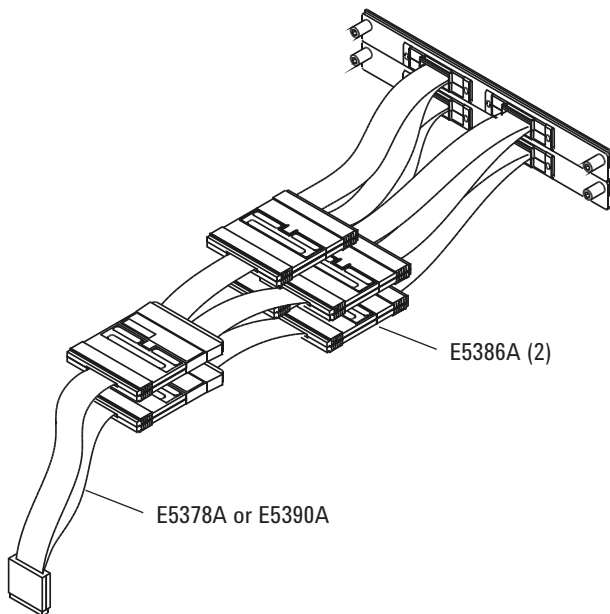

Figure 8.2. E5386A with E5378A, E5390A, or E5406A single-ended probe

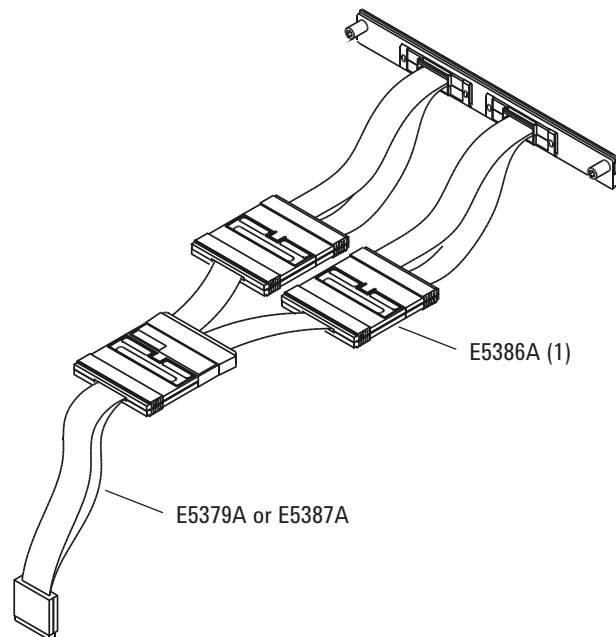

Figure 8.3. E5386A with E5379A, E5387A, or E5405A differential probe

For further information on the application of the E5386A Half-channel adaptor refer to Agilent Technologies E5400-Pro Series Soft Touch Connectorless Probes User's Guide, publication number E5404-97006.pdf

General-Purpose Probing Flying Lead Probing Accessories

Wedge adapters

The Agilent Technologies Wedge technology provides very reliable probing of a few channels on 0.5 mm and 0.65 mm pitch QFPs. No clear area is required around the device. Each Wedge of the probe slides between the legs of the QFP. The side of each Wedge probe contacts the package legs. An insulation core electrically isolates the sides of each Wedge (see Figures 9.1 and 9.2). Various 3-signal, 8-signal, and 16-signal probes are available (see Table 9).

Table 9. Wedge probe adapter

| IC leg spacing | Number of signals | Number of Wedges in pack | Model number |
|----------------|-------------------|--------------------------|--------------|
| 0.5 mm | 3 | 1 | E2613A |
| 0.5 mm | 3 | 2 | E2613B |
| 0.5 mm | 8 | 1 | E2614A |
| 0.5 mm | 16 | 1 | E2643A |
| 0.65 mm | 3 | 1 | E2615A |
| 0.65 mm | 3 | 2 | E2615B |
| 0.65 mm | 8 | 1 | E2616A |
| 0.65 mm | 16 | 1 | E2644A |

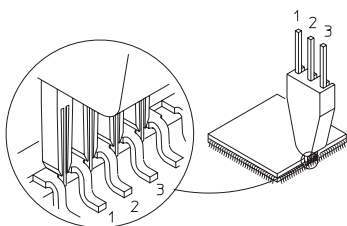
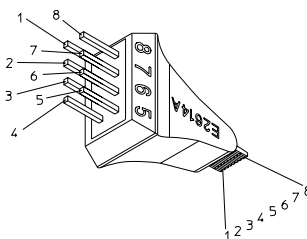
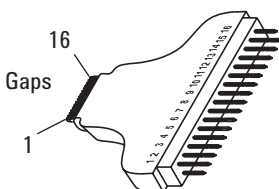

Figure 9.1. Three-signal Wedge electrical connection



Top view of 16 signal pins



Bottom view of 16 ground pins (connected to common ground plane)

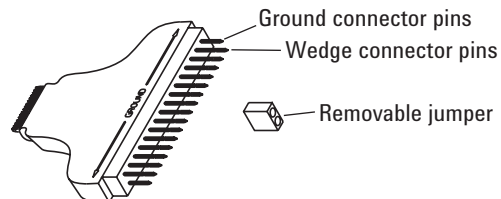

Figure 9.2. Eight-signal and 16-signal Wedge (16-signal Wedge has a common ground plane)

Miscellaneous probing accessories

The ferrite core assembly can be added to the probe cable to suppress EMI and RFI noise that can corrupt the measurement.

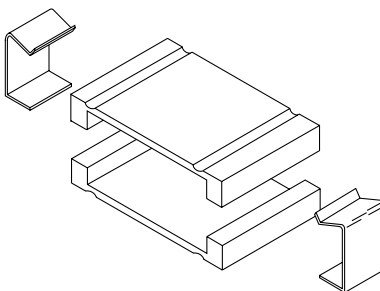

Figure 9.3. Ferrite core assembly, 16555-60001

40-pin and 90-pin Logic Analyzers Probe Cables

Signal line loading

Any probed signal line must be able to supply a minimum of 600 mV (unless noted otherwise — see probe of interest) to the probe tip while the probe is connected to the system. The maximum input voltage of each probe is ± 40 volts peak (unless noted otherwise — see probe of interest).

Probe cables

The probe cable (see Figure 10.1 and Table 10) contains 16 signal lines and two clk lines, two +5 volt power lines, and ground lines for each of

the signal/clock and power lines. All of these lines are contained in a 4.5-foot cable. The probe cable is included with the logic analyzer. The cable grounds are chassis (earth) grounds, not “floating” grounds. The two +5 volt power lines can be used to power active probing systems. Consult the specifications for the individual logic analyzers or logic analyzer cards for the maximum allowable current through each +5 volt power supply.

Caution: These +5 volt power lines MUST NOT be connected to the target’s power supply.

Caution: Be careful when using straight wire probe leads, one common ground, or RC networks located far from the target. These circumstances increase the impact of analog effects such as crosstalk and EMT susceptibility, which contribute to measurement errors.

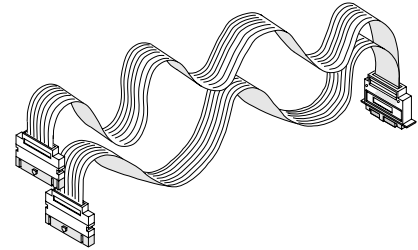

Figure 10.1. Typical logic analyzer probe cable

Table 10. Probe cables supplied with Agilent logic analyzers

| Logic analyzer | 40-pin cable part number | | | | | | 90-pin cable part number | | |
|-----------------|--------------------------|-------------|-------------|-------------|-------------|-------------|--------------------------|-------------|--------|
| | 01550-61607 | 16550-61601 | 01660-61605 | 16555-61606 | 16710-61603 | 16715-61601 | 16760-61605 | 16962-61601 | U4201A |
| U4154A | | | | | | | | | • |
| 16962A | | | | | | | | • | |
| 16951B | | | | | | | • | | |
| 16950A/B | | | | | | | • | | |
| 16911A | | | | | | • | | | |
| 16910A | | | | | | • | | | |
| 16800 Series | | | | | | • | | | |
| 16760A | | | | | | | • | | |
| 16753/54/55/56A | | | | | | | • | | |
| 16752A/B | | | | | | • | | | |
| 16751A/B | | | | | | • | | | |
| 16750A/B | | | | | | • | | | |
| 16740 Series | | | | | | • | | | |
| 16719A | | | | | | • | | | |
| 16718A | | | | | | • | | | |
| 16717A | | | | | | • | | | |
| 16716A | | | | | | • | | | |
| 16715A | | | | | | • | | | |
| 16712A | | | | | • | | | | |
| 16711A | | | | | • | | | | |
| 16710A | | | | | • | | | | |
| 16557D | | | | | • | | | | |
| 16556A/D | | | | • | | | | | |
| 16555A/D | | | | • | | | | | |
| 16554A | | | | • | | | | | |
| 16550A | | | • | | | | | | |
| 1690 Series | | | | | | • | | | |
| 1680 Series | | | | | | • | | | |
| 1670 Series | | | | | • | | | | |
| 1660 Series | | • | | | | | | | |
| 1650 Series | • | | | | | | | | |

Related Information

Agilent Technologies logic analysis third-party partners:

For a complete list of partners, see document 5966-4365EUS *Processor and Bus Support for Agilent Technologies Logic Analyzers*

3M

<http://www.mmm.com/interconnects>

AMP, Inc.

Phone: 1-717-986-7777

Fax: 1-717-986-7575

Phone (USA only): 1-800-522-6752

E-mail: product.info@amp.com

Web site: <http://www.amp.com>

Agilent Technologies Test and Measurement Organization support line phone number: 1-800-452-4844

Agilent Technologies Test and Measurement Organization web site: <http://www.agilent.com>

Agilent Technologies Test and Measurement Logic Analyzers web site: <http://www.agilent.com/find/logic>

Agilent Technologies Test and Measurements Accessories web site: http://www.agilent.com/find/la_probing

This document does not cover the following topics:

- Pattern generator probing and accessories
See: *Agilent 16800 Series Portable Logic Analyzers*, Data Sheet, publication number 5989-5063EN and *Agilent Technologies Measurement Modules for the 16900 Series*, Data Sheet, publication number 5989-0422EN
- Analysis probes for processors and buses
See: *Processor and Bus Support for Agilent Technologies Logic Analyzers*, Configuration Guide, publication number 5966-4365E



Agilent Email Updates

www.agilent.com/find/emailupdates

Get the latest information on the products and applications you select.



www.axistandard.org

AdvancedTCA® Extensions for Instrumentation and Test (AXIe) is an open standard that extends the AdvancedTCA for general purpose and semiconductor test. Agilent is a founding member of the AXIe consortium.



www.lxistandard.org

LAN eXtensions for Instruments puts the power of Ethernet and the Web inside your test systems. Agilent is a founding member of the LXI consortium.



www.pxisa.org

PCI eXtensions for Instrumentation (PXI) modular instrumentation delivers a rugged, PC-based high-performance measurement and automation system.

Agilent Channel Partners

www.agilent.com/find/channelpartners

Get the best of both worlds: Agilent's measurement expertise and product breadth, combined with channel partner convenience.



Agilent Advantage Services is committed to your success throughout your equipment's lifetime. To keep you competitive, we continually invest in tools and processes that speed up calibration and repair and reduce your cost of ownership. You can also use Infoline Web Services to manage equipment and services more effectively. By sharing our measurement and service expertise, we help you create the products that change our world.

www.agilent.com/find/advantageservices



For more information on Agilent Technologies' products, applications or services, please contact your local Agilent office. The complete list is available at:

www.agilent.com/find/contactus

Americas

| | |
|---------------|----------------|
| Canada | (877) 894 4414 |
| Brazil | (11) 4197 3500 |
| Mexico | 01800 5064 800 |
| United States | (800) 829 4444 |

Asia Pacific

| | |
|--------------------|----------------|
| Australia | 1 800 629 485 |
| China | 800 810 0189 |
| Hong Kong | 800 938 693 |
| India | 1 800 112 929 |
| Japan | 0120 (421) 345 |
| Korea | 080 769 0800 |
| Malaysia | 1 800 888 848 |
| Singapore | 1 800 375 8100 |
| Taiwan | 0800 047 866 |
| Other AP Countries | (65) 375 8100 |

Europe & Middle East

| | |
|----------------|----------------------|
| Belgium | 32 (0) 2 404 93 40 |
| Denmark | 45 70 13 15 15 |
| Finland | 358 (0) 10 855 2100 |
| France | 0825 010 700* |
| | *0.125 €/minute |
| Germany | 49 (0) 7031 464 6333 |
| Ireland | 1890 924 204 |
| Israel | 972-3-9288-504/544 |
| Italy | 39 02 92 60 8484 |
| Netherlands | 31 (0) 20 547 2111 |
| Spain | 34 (91) 631 3300 |
| Sweden | 0200-88 22 55 |
| United Kingdom | 44 (0) 131 452 0200 |

For other unlisted countries:

www.agilent.com/find/contactus

Revised: June 8, 2011

Product specifications and descriptions in this document subject to change without notice.

© Agilent Technologies, Inc. 2005, 2011
Published in USA, November 1, 2011
5968-4632E

