



SERIES 4410 DIRECTIONAL RF
THRULINE® WATTMETER

MODEL 4410S

OPERATING INSTRUCTIONS

©COPYRIGHT 2015 BY BIRD ELECTRONIC CORPORATION
INSTRUCTION BOOK PART NUMBER 920-4410S REV. F

THRULINE® AND TERMALINE® ARE REGISTERED TRADEMARKS
OF BIRD ELECTRONIC CORPORATION

Safety Precautions

The following are general safety precautions that are not necessarily related to any specific part or procedure, and do not necessarily appear elsewhere in this publication. These precautions must be thoroughly understood and apply to all phases of operation and maintenance.

WARNING

Keep Away From Live Circuits

Operating Personnel must at all times observe general safety precautions. Do not replace components or make adjustments to the inside of the test equipment with the high voltage supply turned on. To avoid casualties, always remove power.

WARNING

Shock Hazard

Do not attempt to remove the RF transmission line while RF power is present.

WARNING

Do Not Service Or Adjust Alone

Under no circumstances should any person reach into an enclosure for the purpose of service or adjustment of equipment except in the presence of someone who is capable of rendering aid.

WARNING

Safety Earth Ground

An uninterruptible earth safety ground must be supplied from the main power source to test instruments. Grounding one conductor of a two conductor power cable is not sufficient protection. Serious injury or death can occur if this grounding is not properly supplied.

WARNING

Resuscitation

Personnel working with or near high voltages should be familiar with modern methods of resuscitation.

WARNING

Remove Power

Observe general safety precautions. Do not open the instrument with the power on.

Safety Symbols

WARNING

Warning notes call attention to a procedure, which if not correctly performed, could result in personal injury.

CAUTION

Caution notes call attention to a procedure, which if not correctly performed, could result in damage to the instrument.



The caution symbol appears on the equipment indicating there is important information in the instruction manual regarding that particular area

 **Note:** *Calls attention to supplemental information.*

Warning Statements

The following safety warnings appear in the text where there is danger to operating and maintenance personnel, and are repeated here for emphasis.

WARNING

Exposure to RF power radiation and the possibility of RF shock or burns exist under some operating conditions. Always turn off transmitter when connecting or disconnecting wattmeter. Be sure transmission line is terminated into a load or antenna. When plug-in element is removed from the RF line socket, the line section center conductor is exposed. Do not put fingers or other objects into the plug-in element socket while RF power is applied.

On pages 5 and 8.

Caution Statements

The following equipment cautions appear in the text and are repeated here for emphasis.

CAUTION

Model 4412A only.
Do not replace with an alkaline battery.

On pages 16.

CAUTION

If other than Female N type connectors are used, limit power and frequency to the capabilities of the RF coaxial cable or connectors used. Damage to connectors or errors in reading could result.

On pages 18.

Safety Statements

USAGE

ANY USE OF THIS INSTRUMENT IN A MANNER NOT SPECIFIED BY THE MANUFACTURER MAY IMPAIR THE INSTRUMENT'S SAFETY PROTECTION.

USO

EL USO DE ESTE INSTRUMENTO DE MANERA NO ESPECIFICADA POR EL FABRICANTE, PUEDE ANULAR LA PROTECCIÓN DE SEGURIDAD DEL INSTRUMENTO.

BENUTZUNG

WIRD DAS GERÄT AUF ANDERE WEISE VERWENDET ALS VOM HERSTELLER BESCHRIEBEN, KANN DIE GERÄTESICHERHEIT BEEINTRÄCHTIGT WERDEN.

UTILISATION

TOUTE UTILISATION DE CET INSTRUMENT QUI N'EST PAS EXPLICITEMENT PRÉVUE PAR LE FABRICANT PEUT ENDOMMAGER LE DISPOSITIF DE PROTECTION DE L'INSTRUMENT.

IMPIEGO

QUALORA QUESTO STRUMENTO VENISSE UTILIZZATO IN MODO DIVERSO DA COME SPECIFICATO DAL PRODUTTORE LA PROZIONE DI SICUREZZA POTREBBE VENIRNE COMPROMESSA.

SERVICE

SERVICING INSTRUCTIONS ARE FOR USE BY SERVICE - TRAINED PERSONNEL ONLY. TO AVOID DANGEROUS ELECTRIC SHOCK, DO NOT PERFORM ANY SERVICING UNLESS QUALIFIED TO DO SO.

SERVICIO

LAS INSTRUCCIONES DE SERVICIO SON PARA USO EXCLUSIVO DEL PERSONAL DE SERVICIO CAPACITADO. PARA EVITAR EL PELIGRO DE DESCARGAS ELÉCTRICAS, NO REALICE NINGÚN SERVICIO A MENOS QUE ESTÉ CAPACITADO PARA HACERLO.

WARTUNG

ANWEISUNGEN FÜR DIE WARTUNG DES GERÄTES GELTEN NUR FÜR GESCHULTES FACHPERSONAL.

ZUR VERMEIDUNG GEFÄHRLICHE, ELEKTRISCHE SCHOCKS, SIND WARTUNGSARBEITEN AUSSCHLIEßLICH VON QUALIFIZIERTEM SERVICEPERSONAL DURCHZUFÜHREN.

ENTRETIEN

L'EMPLOI DES INSTRUCTIONS D'ENTRETIEN DOIT ÊTRE RÉSERVÉ AU PERSONNEL FORMÉ AUX OPÉRATIONS D'ENTRETIEN. POUR PRÉVENIR UN CHOC ÉLECTRIQUE DANGEREUX, NE PAS EFFECTUER D'ENTRETIEN SI L'ON N'A PAS ÉTÉ QUALIFIÉ POUR CE FAIRE.

ASSISTENZA TECNICA

LE ISTRUZIONI RELATIVE ALL'ASSISTENZA SONO PREVISTE ESCLUSIVAMENTE PER IL PERSONALE OPPORTUNAMENTE ADDESTRATO. PER EVITARE PERICOLOSE SCOSSE ELETTRICHE NON EFFETTUARE ALCUNA RIPARAZIONE A MENO CHE QUALIFICATI A FARLA.

RF VOLTAGE MAY BE PRESENT IN RF ELEMENT SOCKET - KEEP ELEMENT IN SOCKET DURING OPERATION.

DE LA TENSION H.F. PEUT ÊTRE PRÉSENTE DANS LA PRISE DE L'ÉLÉMENT H.F. - CONSERVER L'ÉLÉMENT DANS LA PRISE LORS DE L'EMPLOI.

HF-SPANNUNG KANN IN DER HF-ELEMENT-BUCHSE ANSTEHEN - ELEMENT WÄHREND DES BETRIEBS EINGESTÖPSELT LASSEN.

PUEDA HABER VOLTAJE RF EN EL ENCHUFE DEL ELEMENTO RF - MANTENGA EL ELEMENTO EN EL ENCHUFE DURANTE LA OPERACION.

IL PORTAELEMENTO RF PUÒ PRESENTARE VOLTAGGIO RF - TENERE L'ELEMENTO NELLA PRESA DURANTE IL FUNZIONAMENTO.

About This Manual

This manual covers the operating and maintenance instructions for the following models:

4410A	4410-025	4410-097
4410A500	4410A510	4410A520
4410A530	4410A535	4410A540
4412A		

Changes to this Manual

We have made every effort to ensure this manual is accurate. If you discover any errors, or if you have suggestions for improving this manual, please send your comments to our Solon, Ohio factory. This manual may be periodically updated. When inquiring about updates to this manual refer to the part number and revision on the title page.

Literature Contents

Chapter Layout

Introduction — Describes the features of the Bird SignalHawk, lists equipment supplied and optional equipment, and provides power-up instructions.

Installation — Describes how to connect SignalHawk to the user's system, describes the vector network analyzer measurements, and provides quick start steps for each measurement.

Operation — Describes the power measurement feature, lists compatible power sensors, describes how to connect SignalHawk to the user's system, and provides quick start steps to make power measurements.

Maintenance — Lists routine maintenance tasks as well as troubleshooting for common problems. Specifications and parts information are also included.

TABLE OF CONTENTS

Safety Precautions	i
Safety Symbols	ii
Warning Statements	ii
Caution Statements	ii
Safety Statements	iii
About This Manual	vi
Changes to this Manual	vi
Literature Contents	vi
Chapter Layout	vi
Chapter 1 Introduction	1
Description	1
Component Description	2
Features	2
Optional Equipment	2
Power Requirements	2
Theory Of Operation	3
Coupling Circuit	3
Chapter 2 Installation	5
Portability	5
Installing Battery	5
Inserting in Transmission Line	5
Chapter 3 Operation	7
Connectors	7
Inserting Elements	7
RF Power Measurements	8
Zero Meter	9
Battery Test	9
Frequency Range	9
Power Range Coverage	10
Load Power	10
Determining VSWR	10
Shutdown	12
Performance Notes	13
Chapter 4 Maintenance	15
Care and Cleaning	15
RF Connectors	15
Line Section & Plug-In Element	15

Adjustments	15
Meter & Meter Housing	16
Battery Care	16
Battery Replacement	16
Troubleshooting	17
Meter Replacement	18
Instrumentation Module Replacement	18
RF Connectors Replacement	18
Customer Service	19
Shipment	20
Calibration	20
Equipment Required	20
Calibration Environment	22
Calibration Procedure	22
Replacement Parts List	24
*Available QC Type Connectors	24
Specifications	25
Limited Warranty	27

The Series 4410 ThruLine Wattmeter is an insertion type RF wattmeter designed to measure power flow and load match in 50 ohm RF coaxial transmission lines. Its use is intended for CW unmodulated, or FM signals only. When used in a 50 ohm application with N type connectors, the Series 4410 has an insertion VSWR of less than 1.05 for frequencies up to 1000 Mhz. The meter has two scales, a 0 to 1 scale and a 0 to 3 scale. Power is read as a multiple of the value indicated by the pointer, the decimal point location depending on the range switch setting and the factor on the Plug-in-Element. Several of these Plug-in-Elements may be selected to give this instrument a broad band spectrum with various power ranges, see Specifications, page 25.

Description

The Series 4410 ThruLine Wattmeter is a portable unit contained in a die cast aluminum housing, with a formed sheet aluminum back closure. The unit is equipped with a carrying strap, four rubber shock feet on the base, and four rubber bumpers on the back, which allow the unit to stand in a vertical or horizontal position. For additional protection, the microammeter is specially shock mounted. A slotted screw is provided on the lower front face of the meter for zeroing the pointer. Below the meter, the RF line section face protrudes slightly from the wattmeter housing with the plug-in element socket in the center. Mounted on the line section, inside the housing, is the circuit module with an attached phosphor bronze spring contact finger, which protrudes through a lateral hole and into the plug-in element socket of the RF line section. The finger has a button on its end which makes connection with the contacts of the plug-in element. The silver plated brass RF line section is precision made to provide the best possible impedance match to the coaxial RF transmission line in which the wattmeter is inserted. At each end of the line section are Bird Quick-Change type RF connectors, which may be quickly interchanged with any other Bird "QC" connectors.

Component Description

Meter	Mirrored, 2 scale
Meter Housing	Cast aluminum
QC Connector	Interchangeable input and output
Range Switch	OFF, Battery Check, Various Ranges
RF Line Section Element Port	Accepts 4410 series elements
Rubber Feet	Permit vertical or horizontal position and operation
Calibration Access Hole	Adjustment potentiometer
Instrumentation Module	Active sensing circuitry
Battery 4410 & 4410A 4412A	9V alkaline 9V NiMH rechargeable

Features

To make measurements, the cylindrical shaped plug-in element is inserted into the line section socket and rotated to either stop. A small catch in the lower left hand corner of the casting face presses on the shoulder of the plug-in element and keeps it in proper alignment. This assures a good contact with the DC pickup and between the lower edge of the element and the seat of the line section body. On diametrically opposite sides of the plug-in element body are the contacts that provide DC pickup for either direction. These contacts make connection with the spring finger of the line section only when the plug-in element is in the precise forward or reverse position: i.e., against the stop.

Optional Equipment

The equipment available is a Carrying Case, QC Connectors, and Elements. Consult Bird Electronic Corporation for availability and pricing, or for special requirements.

Power Requirements

The Model 4410 & 4410A operates from one 9V alkaline battery. Approximate battery life is 24 hours of continuous usage. The Model 4412A uses one 9V nickel-metal hydride (NiMH) rechargeable battery or an AC converter. When the AC power is applied, the wattmeter charges the battery and operates from an external power supply. When AC power is removed, the wattmeter operates from the battery.

Theory Of Operation

On any uniform RF line section there are voltages, currents and standing waves present when RF power is applied. These are the results of two travelling waves, forward and reflected. The characteristic impedance of these lines is a pure resistance, usually 50 ohms for useful lines. The main RF circuit of the wattmeter is a short, precision type line section whose characteristic impedance is 50 ohms.

Coupling Circuit

The coupling circuit which samples the travelling waves is in the plug-in element. The circuitry of the element and its relationship to the other components of the wattmeter are illustrated in figure 1. Energy is absorbed in the coupling circuit of the element both by mutual inductance and by capacitance from the travelling RF waves of the line section. These inductive currents flow according to the direction of the travelling waves producing them, whereas the capacitive portion of these currents is independent of the direction. It is, therefore, apparent that the two currents produced from the waves travelling in one direction add in phase, while the currents produced from the waves travelling in the opposite direction subtract in phase. The arrow on the Plug-In Element indicates the additive direction of wave travel. The element is so designed that the currents from the wave components travelling in the opposite direction of the arrow cancel each other out almost completely, making the element highly insensitive to the reverse wave direction. The additive direction signal, which is to be measured, is detected from which an accurate power reading is obtained. Because of the highly directional characteristics of the element, the resultant direct current which is sensed by the microammeter indicates the power level of only the RF waves travelling in the arrow direction.

Figure 1 Element Schematic Diagram

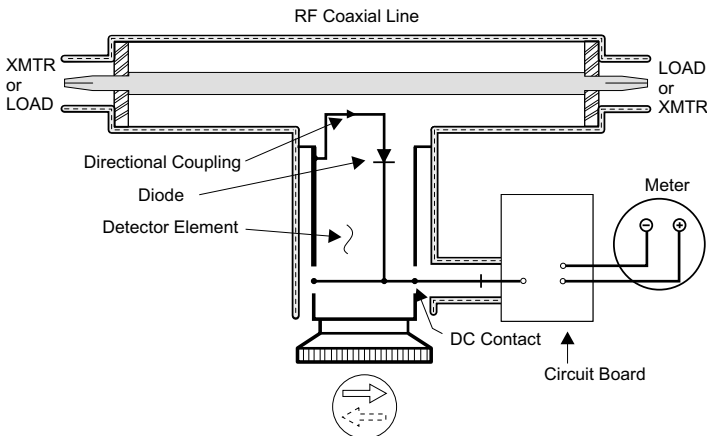

Portability

When transporting the wattmeter, be sure the range switch is in the “off” position. In any other switch position, there is a slight drain on the 9 V battery. If the unit is to be inactive for more than 2 weeks, remove the battery to avoid damage from possible battery leakage. See Battery Care, page 16.

Handle the plug-in elements with care at all times. Calibration could be disturbed if they are dropped or subjected to hard blows.

Installing Battery

The 9 V battery is shipped separately and must be installed before operation. Refer to figure 2 for battery location.

Figure 2 *Battery Installment*

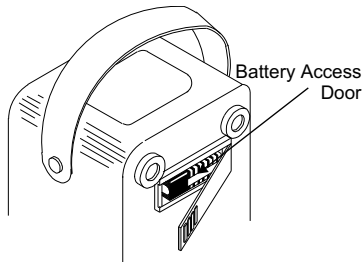

Inserting in Transmission Line

WARNING

Exposure to RF power radiation and the possibility of RF shock or burns exist under some operating conditions. Always turn off transmitter when connecting or disconnecting wattmeter. Be sure transmission line is terminated into a load or antenna. When plug-in element is removed from the RF line socket, the line section center conductor is exposed. Do not put fingers or other objects into the plug-in element socket while RF power is applied.

Insert the Series 4410 ThruLine Wattmeter in coaxial transmission lines of 50 ohms nominal impedance. It makes no difference which side of the wattmeter the power source and the load connections are made. Use a coaxial transmission line fitted with suitable matching RF connectors. If cables of other than 50 ohms impedance are used, a mismatch will occur which could cause serious inaccuracies in the readings.

Connectors

The Series 4410 Wattmeter is normally supplied with two Female N type connectors which are of the Bird Quick-Change “QC” design. Other “QC” connectors are available as listed in the Replacement Parts List, page 24.

Inserting Elements

The plug-in element is inserted into the line section socket and rotated to either stop. A small catch in the lower left hand corner of the casting face presses on the shoulder of the plug-in element and keeps it in proper alignment, refer to figure 3. This assures a good contact with the DC pickup and between the lower edge of the element and the seat of the line section body.

Figure 3 *Element Lock*

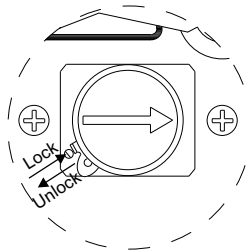

On diametrically opposite sides of the plug-in element body are the contacts that provide DC pickup for either direction, refer to figure 4. These contacts make connection with the spring finger of the line section only when the plug-in element is in the precise forward or reverse position: i.e., against the stop.

Figure 4 *Element*

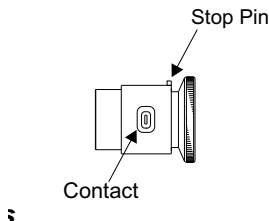

RF Power Measurements

WARNING

Exposure to RF power radiation and the possibility of RF shock or burns exist under some operating conditions. Always turn off transmitter when connecting or disconnecting wattmeter. Be sure transmission line is terminated into a load or antenna. When a Plug-In Element is removed from the RF line socket, the line section center conductor is exposed. Do not put fingers or other objects into the plug-in element socket while RF power is applied.

RF power measurements are made with plug-in elements inserted. Refer to Figure 5.

Figure 5 Measurement Direction

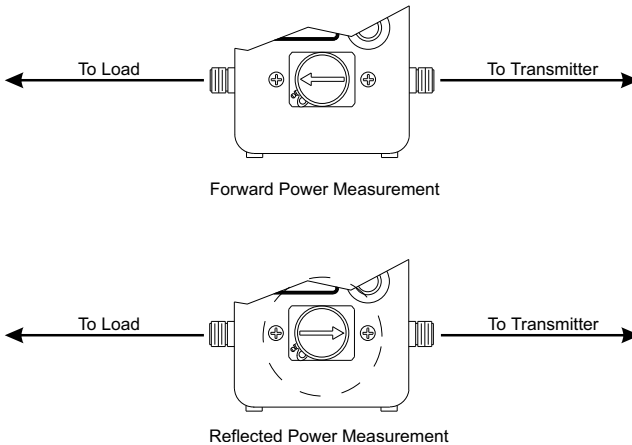

Forward power is indicated when the arrow on the element points in the direction of power flow; i.e., from transmitter to load.

Reflected power measurements are made with the element rotated 180° and the arrow pointing toward the transmitter.

When the power measurements are being made, make sure the element is rotated fully so that the element's stop pin rests against the stop on the line section, either in the forward or reflected position. Also be sure that the lock in the lower left hand corner of the casting face presses on the shoulder of the plug-in element to keep it in proper alignment and assure a good contact with the DC connection and between the lower edge of the element and line section body.

Zero Meter

Before any power measurements are made, be sure the pointer rests on the zero mark. If not, set range switch to OFF position and adjust the zero adjustment screw clockwise or counterclockwise until the pointer rests at the zero mark. This adjusting screw is located at the bottom center of the meter bezel face, refer to figure 6.

Figure 6 Zero Adjustment

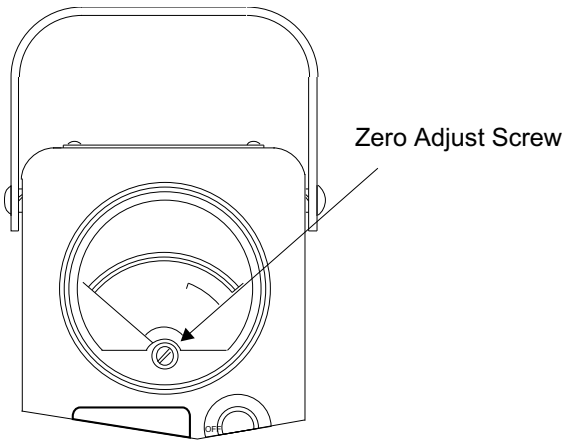

Battery Test

The accuracy of the unit may be affected by a weak battery. Check the condition of the battery occasionally with the battery test position on the range switch. If the pointer on the meter indicates a weak battery, the battery must be replaced (4410 and 4410A) or recharged (4412A). See Battery Care, page 16.

Frequency Range

The elements are selected for the frequency range. Each element is marked with its frequency range; the transmitter frequency must be within this range. A set of several elements will cover a very wide frequency range.

Power Range Coverage

Each element is marked with its maximum power range capability, 10 W, 100 W, 1000 W, or 10000 W. Also stamped on the element nameplate is a factor number. The power range switch on the Series 4410 Wattmeter determines the full scale power range to be used. The available switch settings are 0.1, 0.3, 1, 3, 10, 30, 100, BATT, and OFF. This switch, when set on a numbered position and multiplied by the element factor number, gives the full scale power value. For example, if the element factor is 10 and a switch setting of 30 is opposite the ARROW on the front face of the unit, 30 multiplied by 10 gives you 300 W full scale. In this case, the lower scale (0-3) on the meter face will be used. If the number opposite the ARROW is 10 and the element factor is 10, then $10 \times 10 = 100$, and 100 W will be the full scale reading and the upper scale (0-1) will be used.

For reflected power readings the element is rotated 180° in the element socket and the same system is used, however, a much lower switch setting may be advantageous for better resolution.

Load Power

Where appreciable power is reflected, as with an antenna, it is necessary to subtract the reflected from forward power to obtain load power. Power delivered to and dissipated in an antenna is given by:

This correction is negligible (less than 1 percent) if the load has a VSWR of 1.2 or less.

The Series 4410 ThruLine Wattmeter used with a Bird Termline Load Resistor of proper power rating forms a highly useful absorption wattmeter. Since the reflected power will be negligible, it will be unnecessary to rotate the element from the forward direction.

Determining VSWR

The Series 4410 ThruLine Wattmeter is not designed to provide direct VSWR readings. However, VSWR readings can be determined very easily by using the provided graphs:

Following the vertical and horizontal grid, determine intersection of forward and reverse power values. Slanted lines passing closest to this point indicate VSWR.

1. Determine the forward and reflected power as described above.
2. Refer to the appropriate graph, figure 7 or 8, and convert the forward and reflected power readings to VSWR. Note that the graphs convert the readings directly to VSWR without any intermediate computations.

Figure 7 VSWR Conversion Nomograph

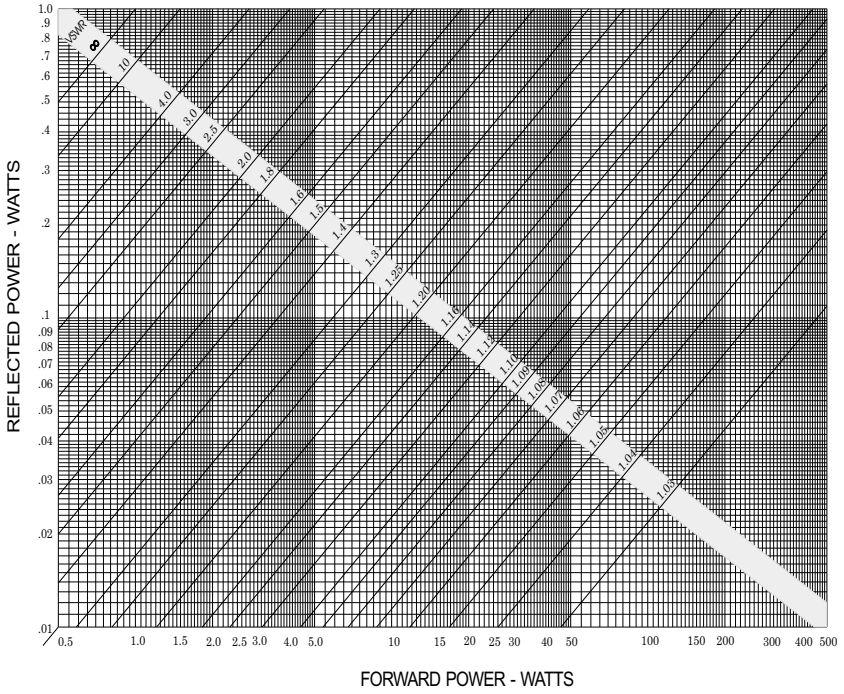
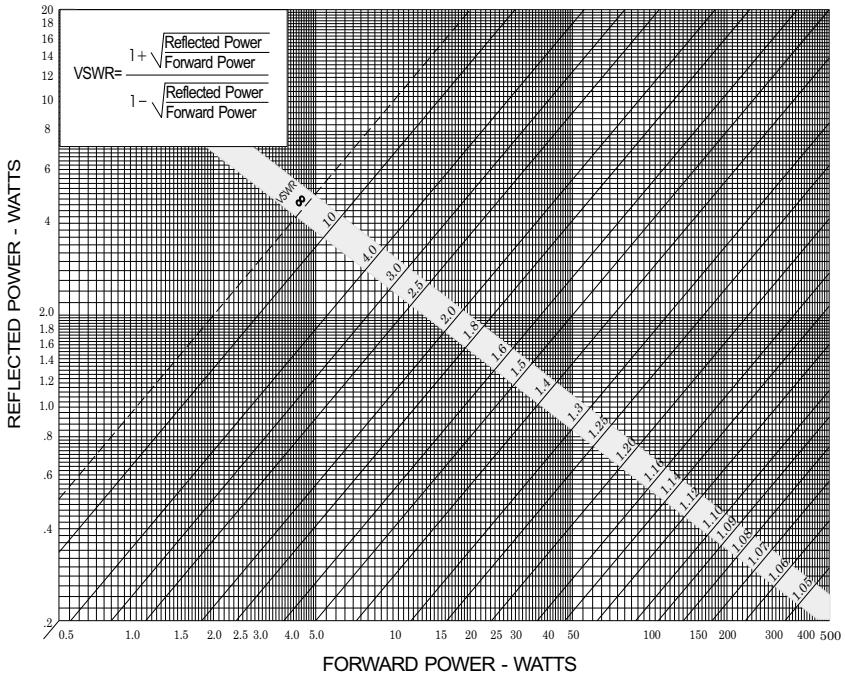

Figure 8 VSWR Conversion Nomograph



Shutdown

When all measurements are completed, be sure to turn the range switch to the OFF position. Leaving the switch on one of the power ranges will not harm the circuit in any way but it will shorten the battery life. Note that there is a battery test position on the range selector switch. This battery test position is provided to conveniently check the condition of the battery each time the Series 4410 is switched on.

Always be sure the transmitter power is off before disconnecting the unit from the transmission line.

Performance Notes

The Series 4410 wattmeter is sensitive to the presence of amplitude modulated signals and this can affect the accuracy. However, small amounts of AM (up to 10%) are tolerable, but for every 1% of AM, the inaccuracy of the reading may increase by up to 1% beyond the rated accuracy. Use above 10% AM is not recommended. The stated accuracy does not include the effect of the less-than-infinite directivity of the element used. This is generally insignificant except for reflected power measurements where VSWR is low.

Although the Series 4410 Wattmeter is equipped with Quick-Change connector types, it must be remembered that the power rating and insertion loss may be affected if other connectors are used. Power limits must be governed by the type of connector or transmission line used. For other types of Quick-Change connectors, see Replacement Parts List, page 24.

When the range switch of the Series 4410 Wattmeter is set in one of the numbered positions; i.e., other than OFF or BATT, it is normal for the meter to drift or deviate off the zero setting. This condition occurs when no element is in the line section socket or if the element is rotated 90° in the line section to a shorting position.

The Series 4410 Thruline Wattmeter is of very rugged construction and requires little care and maintenance.

Maintenance of the wattmeter is normally limited to cleaning. The amount of cleaning necessary can be minimized by keeping the plug-in element or the shipping slug in the socket of the line section. This serves as an effective seal against the entry of dust and dirt. Cover the socket opening when the element is removed. Also, protect the RF connectors on the line section against the entry of dust and dirt by keeping them connected to the transmission line or by covering them when the unit is disconnected from the transmission line.

Care and Cleaning

All contacts must be kept clean to assure low resistance connections to, and within, the unit.

RF Connectors

Clean RF connectors with a cotton swab stick dampened with alcohol, or any acceptable dry cleaning solvent.

Line Section & Plug-In Element

Clean the inside of the line section socket bore and the entire circumference of the plug-in element with a cotton swab stick dampened with alcohol, or any dry cleaning solvent that does not leave any residue. Pay particular attention to the cleaning of the bottom rim of the element body and to the seat of the socket in the line section. When cleaning the socket bore, take care not to disturb the spring finger of the DC contact.

Adjustments

If necessary, the spring finger of the DC contact can be adjusted manually. The button must be positioned out far enough to make good contact with the element body, but it must not restrict the entry of the element body. Check the inside of the line section for dirt and contamination. Clean the reachable portions of the line section with a cotton swab stick. Blow out the remaining dirt with low pressure, dry compressed air. Do not attempt to remove the RF line center conductor from the line section. Any attempt to remove it will damage the assembly.

Meter & Meter Housing

Clean the meter and meter housing using a cloth dampened with a mild detergent solution. Do this only when necessary and take care not to allow water to enter any of the circuitry as damage may result.

Battery Care

The Model 4410 & 4410A will operate for a minimum of 24 hours from one 9 volt alkaline battery. The battery test is used to determine when to replace the battery. Follow the instructions in the Battery Replacement section to install a new battery. The Model 4412A will operate for 7 hours from one fully charged 9 volt NiMH battery before recharging is required. Use the battery test to determine when to recharge the battery. Recharging is accomplished by connecting AC power to the wattmeter. This takes approximately 14 hours when the unit is off. To prolong the life of the battery, it is recommended that it be allowed to fully discharge periodically before recharging. If the battery loses the ability to hold a charge, it can be replaced with a standard 9 volt NiMH battery.

For an extended period of inactivity it is recommended that the battery be removed from the unit and stored in the proper environment. To achieve the longest battery life, the most advantageous storage temperatures are between +10° and +35° C (50° to 95° F) at a relative humidity of 50%.

CAUTION

Model 4412A only

Do not replace with an alkaline battery.

Battery Replacement

The battery holder is located on the back of the unit near the top of the meter housing cover. Refer to Figure 2 on page 5.

1. Open the battery compartment cover.
2. Slide the battery out of the compartment.
3. Remove the snap-on battery plug.
4. Replace battery with a new one.
5. Feed wires through hole in back of compartment.
6. Place battery in compartment.
7. Close compartment.

Troubleshooting

The Series 4410 ThruLine Wattmeter is designed for independent, long term, trouble free operation. In case of malfunction or for replacement of a major component —particularly if it is still under warranty—return the unit to the factory. Do not tamper with the calibration setting or do other unauthorized maintenance work during the first year, or you may void the warranty. Test and calibration in the field may be performed as described in the Calibration paragraph. A troubleshooting table, listing some of the most common problems, see Table 1.

The troubleshooting table contains a list of possible problems experienced in the field, as well as their possible cause and remedy.

Table 1: Troubleshooting

Problem	Possible Cause	Remedy
No meter indication	No RF power. Weak or dead battery.	Check RF source. Test the battery and replace if faulty.
	Arrow on plug-in element pointing in wrong direction.	Reposition element so that the arrow points in the direction of power flow.
	No pick-up from DC contact finger.	Adjust, see Maintenance.
	Open or short circuit in DC meter leads.	Replace defective leads.
	Meter burned out or damaged wattmeter.	Replace or return to the factory for replacement and recalibration.
Intermittent or Inconsistent Meter Readings	Faulty transmission line or load.	Inspect line connections, antenna or load.
	Dirty DC contact on elements.	Clean, see Maintenance.
	Sticky or defective meter.	Replace or return wattmeter to the factory for meter replacement and recalibration.
High percentage of reflected power	Bad load or poor connectors.	Replace load, antenna or connectors.
	Shorted or open transmission line.	Service or replace line.
	Foreign material in line section or in RF connector.	Check for foreign material and clean as required.

Meter Replacement

1. Remove back cover.
2. Loosen the two #8-32 nuts on the back of the meter that secure the meter leads.
3. Remove the leads.
4. Remove the two #10-32 oval head phillips screws that secure the meter shock ring.

Note: *These screws are located on each side of the meter housing just opposite the meter.*

5. Pull the meter out of the back of the housing.
6. Remove the meter retaining ring and shock mount.
7. Replace the meter by reversing the procedure above.

Note: *Be sure to observe polarity when replacing the leads to the meter, black to negative, etc.*

Instrumentation Module Replacement

Note: *The instrumentation module contains the line section and circuit board chassis as an integral part.*

1. Loosen the set screw in the range switch knob by turning in a counterclockwise direction with a .050 allen wrench.
2. Pull the knob straight off.
3. Unsolder the leads from the connections on the top of the circuit board chassis.

Note: *Take note of the color coding when unsoldering so the leads can be reconnected to their original positions.*

4. Remove the two oval head phillips screws located on the front face of the unit on either side of the line section element port.
5. Pull the instrumentation module out of the back of the unit.
6. Replace the instrumentation module by reversal of the above procedure.

Note: *Be sure to reconnect the wires to their original positions.*

RF Connectors Replacement

CAUTION

If other than Female N type connectors are used, limit power and frequency to the capabilities of the RF coaxial cable or connectors used. Damage to connectors or errors in reading could result.

1. Remove the four screws in the corners of the connector flange.
2. Pull the connector straight off carefully.
3. Replace the connector by reversing the procedure above.

Note: *See Replacement Parts List for other available connectors.*

Customer Service

Any maintenance or service procedure beyond the scope of those in this chapter should be referred to a qualified service center.

If the unit needs to be returned for any reason, request an RMA through the Bird Technologies website. All instruments returned must be shipped prepaid and to the attention of the RMA number.

Bird Service Center

30303 Aurora Road
Cleveland (Solon), Ohio 44139-2794
Fax: (440) 248-5426
E-mail: bsc@bird-technologies.com

For the location of the Sales Office nearest you, visit our Web site at:

<http://www.birdrf.com>

Shipment

Should you need to return the power meter, use the original shipping package if possible. If the original package is not available, use a heavy duty corrugated box with shock-absorbing material around all sides of the unit to provide firm cushion and to prevent movement in the container. The container should be properly sealed.

Calibration

This procedure provides a means for complete calibration of the Series 4410 Thruline Wattmeter Assembly. The calibration of the elements is not covered by this procedure.

- The sine wave generator must be able to produce a stable 1000Hz \pm 100Hz symmetrical sine wave at various RMS output voltages between 0.05 and 1.6 volts RMS into an impedance of approximately 600 ohms resistive. Its output level adjustment must be such that these various specific output levels can be conveniently adjusted to within \pm 0.3% of their stated value. Total harmonic distortion must be less than 0.2%.
- The digital multimeter must have an ac voltmeter range capable of measuring the RMS voltage amplitude of the sine wave within \pm 0.1%, with a resolution of at least 3½ significant digits.
- The Bird Plug-In Calibration Element requires no adjustment. However, care should be taken to avoid damage to the unit from rough handling or exposure to voltages greater than those specified.
- The field strength meter should be set on its maximum sensitivity. 5. Connect the sine wave generator and voltmeter to a BNC adapter tee as shown in figure 9 with 50 ohm coaxial cables, such as RG-58-U, no more than three feet (approx. 1 meter) long.

Equipment Required

Item	Qty	Description	Recommendation
1	1	Standard digital multimeter	Fluke Model 87
2	1	Plug-In calibration element	Bird Model 4410-070
3	1	BNC test leads/adapters	As Required
4	1	Sine wave generator	Hewlett Packard Model 329A

Figure 9 Calibration Set-Up

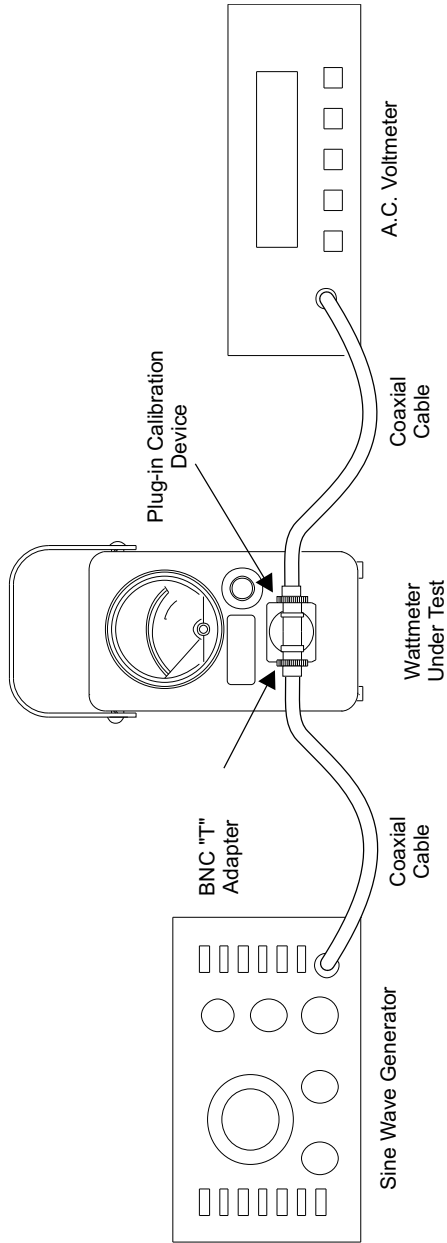

Calibration Environment

In order to assure the best results obtainable, the following environmental conditions must be provided to the utmost degree practical.

1. The work space must be free from electrical noise and radiated signals.
2. The work space and equipment must be at a uniform and stabilized ambient temperature between 20°C and 25°C (68°F to 77°F).
3. The relative humidity of the work space must be no greater than 50 percent and must be noncondensing.

Calibration Procedure

Allow all the equipment and the instrument to be calibrated to completely stabilize with respect to the environment of the work area (specified above). The Series 4410 Wattmeter to be calibrated and the Bird Model 4410-070 calibration element may require up to 24 hours for complete environmental stabilization if brought from an extreme storage environment. Remove the dust plug or any element from the line section during this environmental stabilization period.

With the wattmeter's range switch in the OFF position, carefully turn the zero adjust screw on the face of the meter for a zero setting. Using the BATT and OFF positions on the switch, repeat this process until a repeatable zero setting is obtained.

The access hole for the calibration potentiometer is sealed with a protective label. This label, which is signed and dated showing the original calibration date, must not be disturbed until recalibration becomes necessary and certainly not within the warranty period. Disturbing this label voids the warranty. If the unit is to be field calibrated, after the warranty period, access to the calibration potentiometer is provided by piercing the protective label at the point shown by a circle with an "X" in it, see figure 10, Calibration Potentiometer for reference.

Follow the steps below to calibrate:

1. Connect the sine wave generator, the calibration element (P/N 4410-070), as shown in figure 9, Calibration Set-Up.
2. Turn on the ac voltmeter and sine wave generator.
3. Adjust the output to 1.591 ± 0.0005 volts RMS at $1000 \text{ Hz} \pm 100 \text{ Hz}$. make sure that the generator's "symmetry", "offset", and "waveform" controls are set to provide a symmetrical sine wave with zero DC offset.

Note: *Leave the equipment in this condition to stabilize for the period of time recommended by the manufacturers but not less than five minutes.*

4. Turn the range selector switch to the "100" position and allow the wattmeter a minimum of five minutes to stabilize.

Note: *The wattmeter does not need to be connected to the calibration setup for the five minute warm-up period.*

5. After the equipment has stabilized, check the battery in the wattmeter by momentarily placing the range switch in the BATT position. The meter pointer should travel well into the "BATTERY TEST" region of the meter scale. If not, turn the unit off and replace the battery.
6. Return the switch to the "100" position.
7. Allow the unit's internal circuitry to stabilize for another five minutes if the battery was replaced.
8. Insert the calibration element into the wattmeter and rotate it in either direction until it stops.
9. Recheck the sine wave generator for the proper 1000Hz \pm 100Hz output settings, then readjust the amplitude as necessary until the voltmeter reads a stable 1.591 ± 0.0005 volts.
10. Turn the 4410-070 calibration element 90° to short circuit the spring contact in the line section to the line section body.
11. Set the range switch to the "1" position.
12. Adjust the sine wave generator's output to the wattmeter's calibration voltage.

Note: *This calibration voltage is recorded on a label inside the instrument's back cover. If no calibration voltage is listed, adjust the sine wave generator's output to 0.1591 ± 0.00005 volts RMS.*
13. Rotate the calibration element in either direction until it stops.
14. Adjust R26 until the meter pointer rests at "1" on the upper scale. Calibration is complete.

Figure 10 Calibration Potentiometer

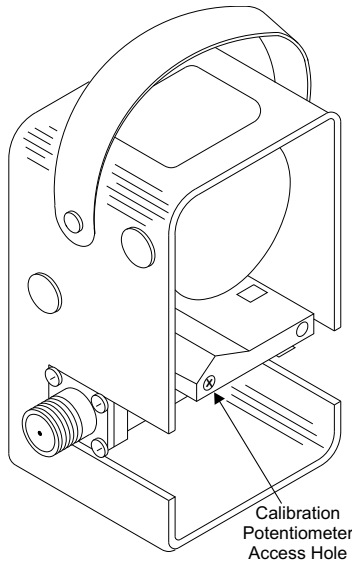

Replacement Parts List

Item	Qty	Description	Part Number
1	1	Meter, DC	2080-066
2	1	Instrumentation Module Assembly (Includes line section and instrumentation)	4410A205
3	1	Strap (Included in housing assembly)	8580A003
4	1	Selector Switch Knob	4410-028
5	1	Meter Housing Assembly	4410-003
6	1	Meter Housing Cover Assembly	4410-039
7	1	Battery Model 4410 & 4410A (Alkaline) Model 4412A (NiMH)	5-1357 5A1587
8	1	Fuse, 100A 250V Model 4412	A5-1976-6
9	1	Power Cord / Converter, 4412A 120V 230V	5A2229 5A2226
10	2	"QC" Connectors (Female "N" normally supplied)	*See Below

*Available QC Type Connectors

N-Female	4240-062	LT-Male	4240-012
N-Male	4240-063	C-Female	4240-100
HN-Female	4240-268	C-Male	4240-110
HN-Male	4240-278	UHF-Female (SO-239)	4240-050
LC-Female	4240-031	UHF-Male (PL-259)	4240-179
LC-Male	4240-025	7/8" EIA Air Line	4240-002
BNC-Female	4240-125	7/16" Female	4240-344
BNC-Male	4240-132	7/16" Male	4240-363
LT-Female	4240-018		

Specifications

Insertion VSWR	1.05 maximum, 0-1GHz equipped with Female N connectors (32.3 dB return loss)
Over Ranging	120% of element power rating regardless of selector switch setting (Certain connector types limited to rating of connector)
Power Range†	2mW to 10W, 20mW to 100W, 200mW to 1000W or 2W to 10kW full scale in one Plug-in element. Any Bird 4410-series element may be used.
Frequency Range†	200kHz to 2.3GHz CW or FM. Select from 4410-series elements only.
Accuracy*	±5% of reading above 20% of full scale of the selected power range for FM or CW signals without AM. This accuracy is maintained for a full 37dB dynamic range with each 4410 element
Temperature Range Operating Storage††	0° to 50°C (32°F to 122°F) -25° to 65°C (-13°F to 149°F)
Relative Humidity	5% to 90% noncondensing
Battery Model 4410 & 4410A Model 4412A	Internal alkaline (24 hours minimum life) Internal NiMH (7 hours minimum from full charge)
Connectors	Over 30 types of field-interchangeable "Quick Change" connectors are available. Female N normally supplied.
Elements	4410 Series type, not interchangeable with other Bird elements
Finish	Grey Powder Coat
Normal Size (includes connectors)	6-7/8"H x 5-1/8"W x 3-5/8"D (175 x 130 x 92 mm)
Weight (Approx.) Model 4410 & 4410A Model 4412A	4 lb. (1.8 kg) with N-Connectors 3-1/3 lb. (1.5 kg)

* *Exceptions - Element P/N 4410-1 (0.200 to 0.533MHz) has an accuracy of ±10% of reading. Elements P/N 4410-15 (1.0 to 1.8GHz) and 4410-16 (1.8 to 2.3GHz) which are accurate to ±8% of reading.*

† *Power and frequency range is determined by 4410 type Plug-In Elements used.*

†† *See Battery Care, page 16*

LIMITED WARRANTY

All products manufactured by Seller are warranted to be free from defects in material and workmanship for a period of one (1) year, unless otherwise specified, from date of shipment and to conform to applicable specifications, drawings, blueprints and/or samples. Seller's sole obligation under these warranties shall be to issue credit, repair or replace any item or part thereof which is proved to be other than as warranted; no allowance shall be made for any labor charges of Buyer for replacement of parts, adjustment or repairs, or any other work, unless such charges are authorized in advance by Seller.

If Seller's products are claimed to be defective in material or workmanship or not to conform to specifications, drawings, blueprints and/or samples, Seller shall, upon prompt notice thereof, either examine the products where they are located or issue shipping instructions for return to Seller (transportation-charges prepaid by Buyer). In the event any of our products are proved to be other than as warranted, transportation costs (cheapest way) to and from Seller's plant, will be borne by Seller and reimbursement or credit will be made for amounts so expended by Buyer. Every such claim for breach of these warranties shall be deemed to be waived by Buyer unless made in writing within ten (10) days from the date of discovery of the defect.

The above warranties shall not extend to any products or parts thereof which have been subjected to any misuse or neglect, damaged by accident, rendered defective by reason of improper installation or by the performance of repairs or alterations outside of our plant, and shall not apply to any goods or parts thereof furnished by Buyer or acquired from others at Buyer's request and/or to Buyer's specifications. In addition, Seller's warranties do not extend to the failure of tubes, transistors, fuses and batteries, or to other equipment and parts manufactured by others except to the extent of the original manufacturer's warranty to Seller.

The obligations under the foregoing warranties are limited to the precise terms thereof. These warranties provide exclusive remedies, expressly in lieu of all other remedies including claims for special or consequential damages. SELLER NEITHER MAKES NOR ASSUMES ANY OTHER WARRANTY WHATSOEVER, WHETHER EXPRESS, STATUTORY, OR IMPLIED, INCLUDING WARRANTIES OF MERCHANTABILITY AND FITNESS, AND NO PERSON IS AUTHORIZED TO ASSUME FOR SELLER ANY OBLIGATION OR LIABILITY NOT STRICTLY IN ACCORDANCE WITH THE FOREGOING.

