

HP 4142B Modular DC Source/Monitor

Technical Data

Maximize yield and
improve device quality
with this modular DC
parametric tester
and software.



Use the HP 4142B to...



Improve Process Yields

- Verify the quality of your processes
- Design and control new processes
- Slash test times and reduce costs

**Assure process
quality in
manufacturing**

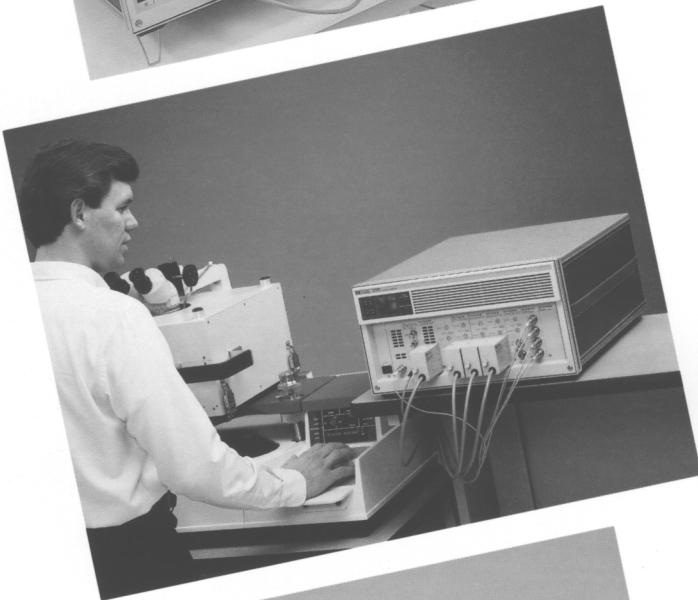

Decrease Development Time

- Develop sub-micron and high power technologies
- Characterize new materials
- Move smoothly from R/D to production

**Perfect new IC
designs and
processes**

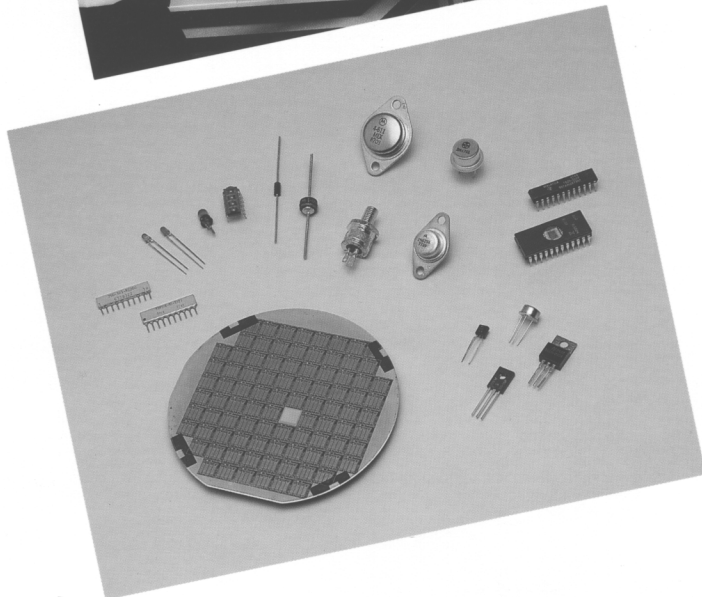

Quickly Evaluate Finished Components

- GaAs FETs and diodes
- Bipolar transistors
- MOS and CMOS structures
- Power Bipolar and MOSFETs
- Thyristors and SCRs
- Operational amplifiers
- Resistive networks
- Smart power devices

**Easily
characterize both
wafers and
packaged parts**

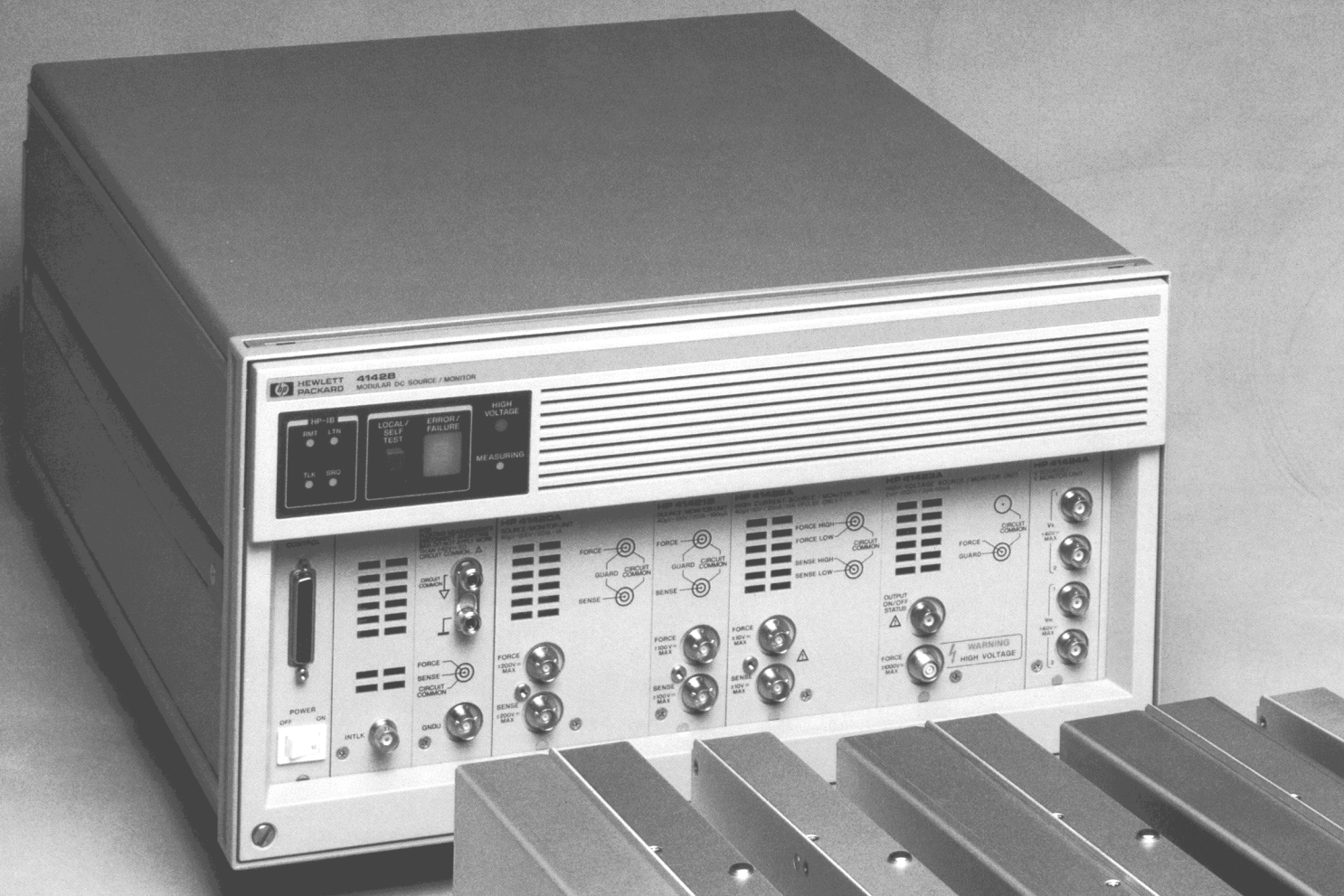

**Configure These Modules
To Your Exact Requirements**

- Wide Measurement Range
(± 20 Amperes, ± 2000 Volts)
- Excellent Sensitivity
(20 fA , $4 \mu\text{V}$)
- Lightning Fast Speed
($12 \text{ msec } V_{th}$ or h_{FE} measurement)
- Highly Accurate
(5-digit, $.05\% \text{ V}$ and $0.2\% \text{ I}$)
- Many Measurement Modes
(Pulsed or DC, Analog Search, Linear, Log, and Dual Channel Sweeps)



HP 4142B Modular DC Source/Monitor

Choose the Right Performance

The HP 4142B represents a new class of user-configurable parametric testers. Its open architecture accommodates a wide variety of applications without compromising performance or expansion capabilities. Each module slips easily into one or more of the eight slots in the HP 4142B chassis. Select only those plug-in modules you need to build a cost effective solution.

Slash Test Times

Force or measure voltages or currents in as little as 4 msec. Sweeps are even faster. And with the HP 41425A Analog Feedback Unit, you can swiftly find single-point threshold voltage or h_{FE} in only 12 msec.

The fast HP-IB interface and two firmware memories allow sustained speeds of 100 tests per second, including data transfer. With the program memory, group as many as 2000 instrument commands into test sequences. Once initiated, these test sequences require no computer control. As measurements are completed, the HP 4142B stores the results in its data buffer. Up to 4095 measurement points are held until the computer is ready to accept the data.

Easily Synchronize Plug-in Modules

Built-in synchronization between plug-in modules assures measurement integrity at high test speeds, regardless of the combination. With two synchronized modules, you can safely perform dual pulsed sweeps on GaAs FETs or reduce test times for transistor gain or threshold voltage measurements using advanced analog search commands. Compare these throughput features with other instruments, and you see why the HP 4142B will reduce test time and thereby cut costs.

Improve Device Quality

With the 5-digit, 20fA and 4 μ V resolution, you can easily evaluate low level voltage and current characteristics such as resistivity, source resistance, and leakage currents.

Extracting high power parameters is simple too. Combine two HVU modules to test voltage breakdowns to ± 2000 volts. Or use two HCU modules to minimize thermal drift when pulse testing GaAs devices, power MOSFETs, bipolar transistors, and smart power ICs to $\pm 20A$. One instrument lets you test a wide variety of devices.



Easily Create Turnkey Solutions with...

- Interactive Measurement and Analysis Software
- Characterization and Modeling Programs
- Automatic Test Generators

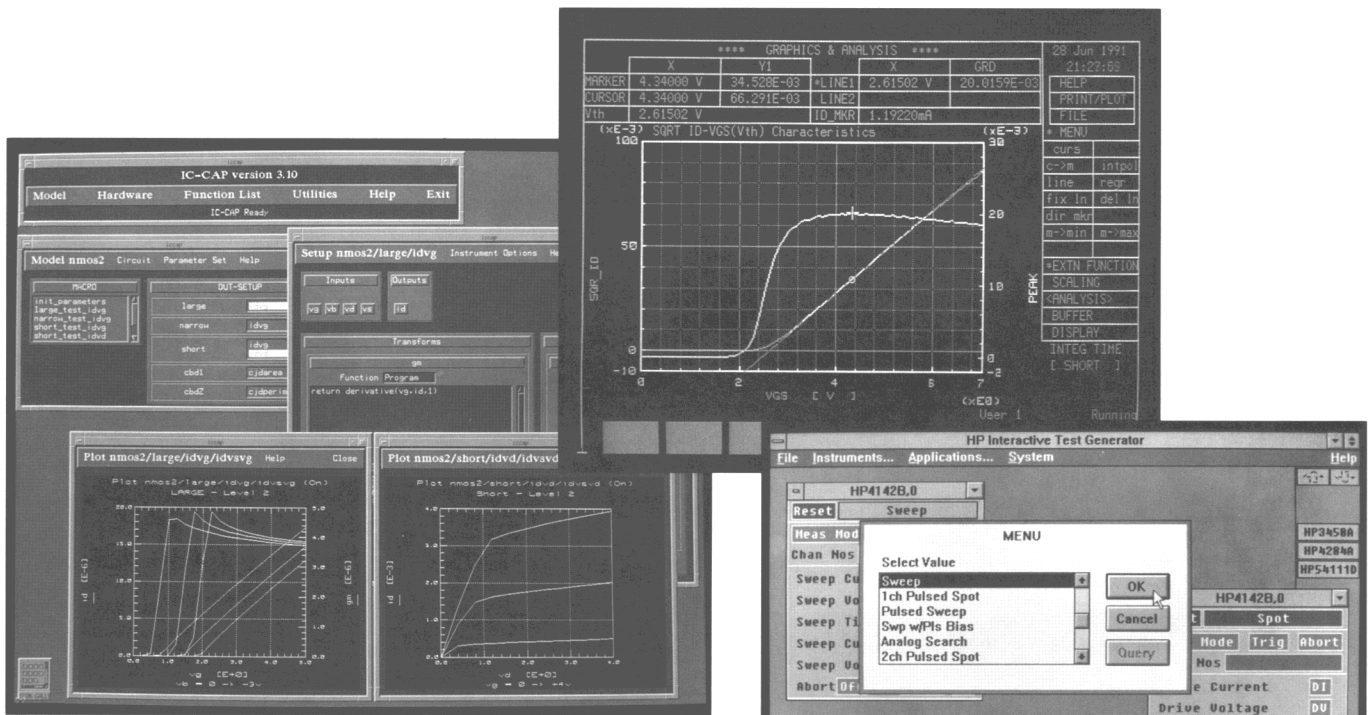

Choose the Right Software Solution

HP provides ready-to-go DC parameter analysis software for the HP 4142B tailored to meet your interactive process or device characterization needs. Easily expand to custom bench-top evaluation or high throughput production test. Choose from HP supported interfaces and software productivity tools which cover a wide range in industry accepted computer platforms.

Whether your application requires PC-based, UNIX, or HP BASIC workstation control, you can use friendly windowed development software and supplied high-level instrument I/O drivers to rapidly create automated test solutions.

Solutions

Process and Device Development

- Full feature parameter analyzer
- Mouse-driven, HP 4145B-style softpanels
- Wide measurement range: 20fA to 20A, and 4 μ V to 2000V
- Integrate other instruments with HP BASIC control

Interactive Measurement and Analysis (IMA) software turns the HP 4142B into a full feature parameter analyzer. This mouse-driven graphical interface is patterned after the industry standard HP 4145B parameter analyzer user interface. Even setup and data file compatibility was maintained so that HP 4145 users can use existing tests with IMA. Pulse large currents through GaAs devices or evaluate low level currents in you MOS processes with advanced features which go well beyond the limits of the HP 4145.

IMA consists of a set of softpanels which allow quick setup and measurement of very complex semiconductor parameters. This is made possible with IMA's user functions which allow data to be plotted and then graphically analyzed according to any arbitrary formula. Valuable engineering time is saved by directly displaying calculated transistor parameters, such as extrapolated threshold voltage, without the need for any post processing.

All of IMA's interactive and analysis features are supported as subroutines in HP BASIC. Use this high level subprogram library to quickly create turnkey semiconductor evaluation systems.



Use HP IMA with the HP 4142B to make complex semiconductor measurements in seconds.

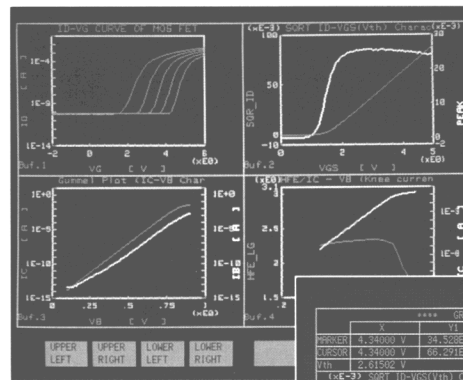

*** LIST ***

[VR1] VGS + 0.0000 V to 5.0000 V in 50.0000mV step

[VR2] current VR2 to 5.0000mV in 50.0000mV step

| VR | VGS | ISUB_ID | PERK | ID | Meas. No. | I |
|----|----------|----------|-----------|---------|-----------|---|
| 1 | 0.000 V | 2.45E-06 | 7.55E-06 | 0.000 A | | |
| 2 | 50.00mV | 2.27E-06 | -1.52E-06 | 0.000 A | | |
| 3 | 100.00mV | 2.36E-06 | 864.E-09 | 0.000 A | | |
| 4 | 150.00mV | 2.36E-06 | 1.39E-06 | 0.000 A | | |
| 5 | 200.00mV | 2.44E-06 | 2.38E-06 | 0.000 A | | |
| 6 | 250.00mV | 2.60E-06 | 4.09E-06 | 0.000 A | | |
| 7 | 300.00mV | 2.85E-06 | 5.91E-06 | 0.000 A | | |
| 8 | 350.00mV | 3.19E-06 | 9.25E-06 | 0.000 A | | |
| 9 | 400.00mV | 3.77E-06 | 14.2E-06 | 0.000 A | | |
| 10 | 450.00mV | 4.61E-06 | 20.6E-06 | 0.000 A | | |
| 11 | 500.00mV | 5.63E-06 | 29.7E-06 | 0.000 A | | |
| 12 | 550.00mV | 7.93E-06 | 41.6E-06 | 0.000 A | | |
| 13 | 600.00mV | 9.92E-06 | 58.2E-06 | 0.000 A | | |

USERID: _____

Single append abort User 1 Caps Running
prev next
display display

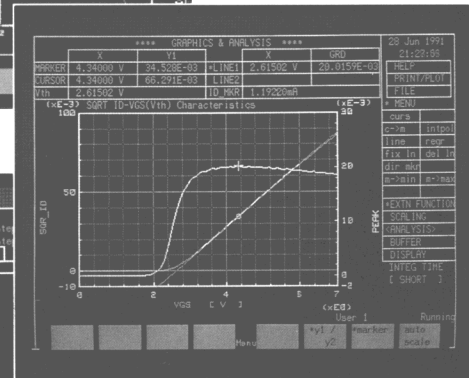

Choose the display mode which best suits your evaluation needs.

Solutions

HP IMA softpanel pages correspond to the way an engineer organizes his job flow. The **Unit Definition** page assigns names to both SMU and user computed variables. These names are then assigned sweep ranges or fixed values in the **Source Setup** page. A list of all variable names is provided for you in the **Display Mode Setup** page. By simply clicking the mouse, you assign names to axes for plotting results or column headings for listing results. Here also, two additional user functions may be defined. This feature allows post processing of previously taken test data. Finally, the **Graphics and Analysis** page facilitates measurement execution and graphical analysis.

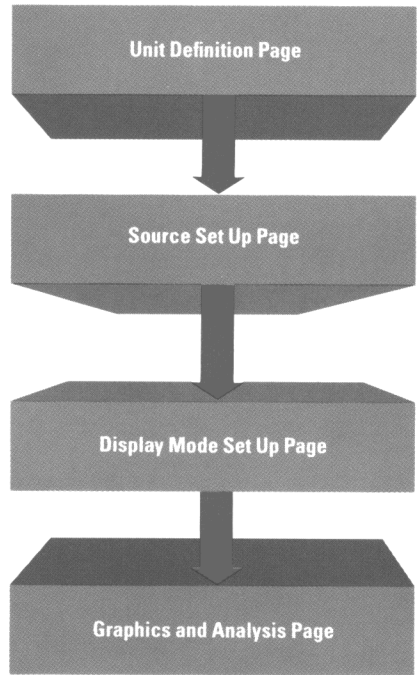

Four softpanel pages minimize the time required to obtain computed semiconductor parameters.

The screenshots show the following data:

Unit Definition Page:

| SLOT NO. | UNIT ID | V. NAME | I. NAME | MODE | FUNCTION |
|----------|-----------|-----------------|-----------------|-------|----------|
| 2 | SMU1 (HP) | V _S | I _D | V | CONST |
| 3 | SMU2 (HP) | V _{GS} | I _G | V | VAR1 |
| 4 | SMU3 (HP) | V _{BG} | I _{BG} | V | CONST |
| 5 | SMU4 (HP) | | | | |
| 6 | VSU1 | | | [V] | |
| 6 | VSU2 | | | [V] | |
| 6 | VBU1 | | | [V] | |

Source Set Up Page:

| NAME | [VBG] | [VBG2] |
|------------|------------|----------|
| NAME | [VGS] | [----] |
| SWEEP MODE | [SINE] | [----] |
| LN / LOG | [LINEAR] | [----] |
| START | 0.00000 V | [----] |
| STOP | 5.00000 V | [----] |
| STEP | 50.0000mV | [----] |
| NO OF STEP | 101 | [----] |
| COMPLIANCE | 1.00000mH | [----] |
| POWER COMP | [----] | [----] |

Display Mode Set Up Page:

| NO. | NAME | (UNIT) | * EXPRESSION |
|-----|---------------------|--------|--------------|
| 1 | V _{th} | [V] | * XL1 |
| 2 | I _D PKR1 | [A] | * Y1*Y11 |

Graphics and Analysis Page:

| NAME | X | Y1 | Y2 |
|-------|-----------------|-------------|-------------|
| NAME | V _{GS} | SQR_ID | PEAK |
| SCALE | LINEAR | LINEAR | LINEAR |
| MIN | 0.00000 V | -10.000E-03 | -2.0000E-03 |
| MAX | 5.00000 V | 100.000E-03 | 30.000E-03 |
| STEP | 400.000mV | 10.000E-03 | 2.0000E-03 |

Fill-in-the-blank soft panels eliminate the need for programming.

Solutions

Device Modeling

- Integrated measurement and simulation environment
- Graphical user interface
- Advance macromodeling

Achieving the best performance with your technology requires accurate device characterization. You need to know how actual performance compares to theoretical models. With IC-CAP, Integrated Circuit Characterization and Analysis Program, quickly use virtual front panels to set up instruments and gather DC and AC device characteristics. Study complex device structures, look at second order transistor effects such as parasitics, or model entire circuits such as gain blocks or digital logic gates.

Measured and simulated data can be transformed through a user-selected function or equation that provides insight into device behavior. IC-CAP is an OPEN system and can be easily integrated with various simulators and databases. All capabilities are available on line, without programming or code compilation.

IC-CAP is an X window/MOTIF based system which runs under UNIX. It supports microwave, LCR meters, scanners, DVMs, power supplies and other instrumentation which can easily be integrated into total characterization solutions with the HP 4142B.

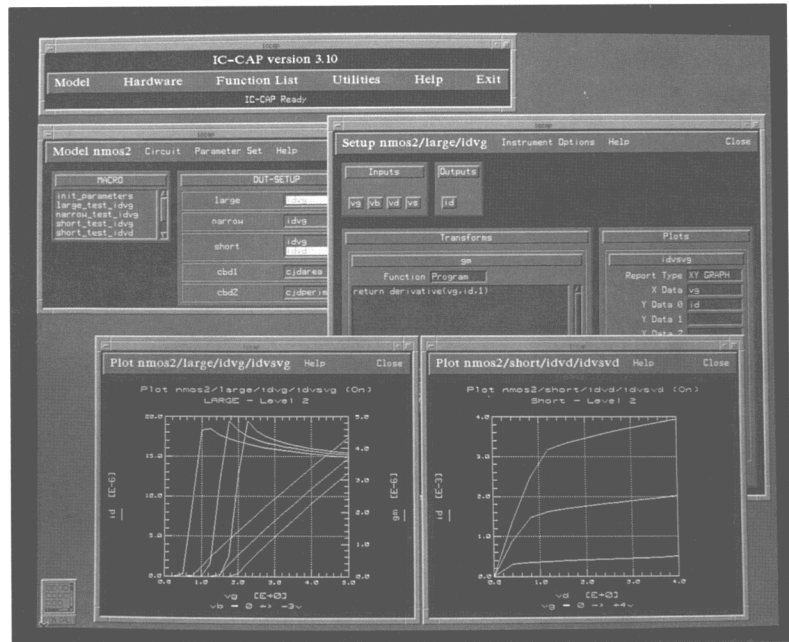

Quickly compare simulated and measured data on line, with IC-CAP's powerful HP-UX windowed interface.

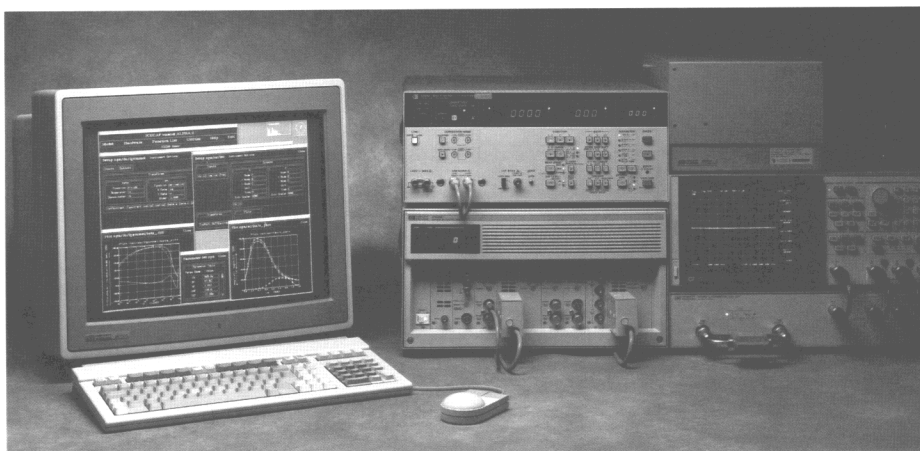

IC-CAP supports the HP 4142B with other instruments for complete DC/CV/AC/TD characterization and modeling.

Solutions

Quickly Create Benchtop Test Solutions Using Interactive Test Generation

- Access hundreds of popular HP instrument drivers
- Create measurement code quickly and interactively
- Solve problems fast with HP VEE icon-based software

As a program developer, use the Interactive Test Generator (ITG) to significantly reduce code development times. ITG provides a windowed, mouse-driven environment designed specifically for instrument control. Create complex and efficient test sequences without learning low level HP-IB programming.



Automated testing and interactive control is easy with ITG.

ITG provides interactive front panel control for the HP 4142B and generates executable code in BASIC or C.

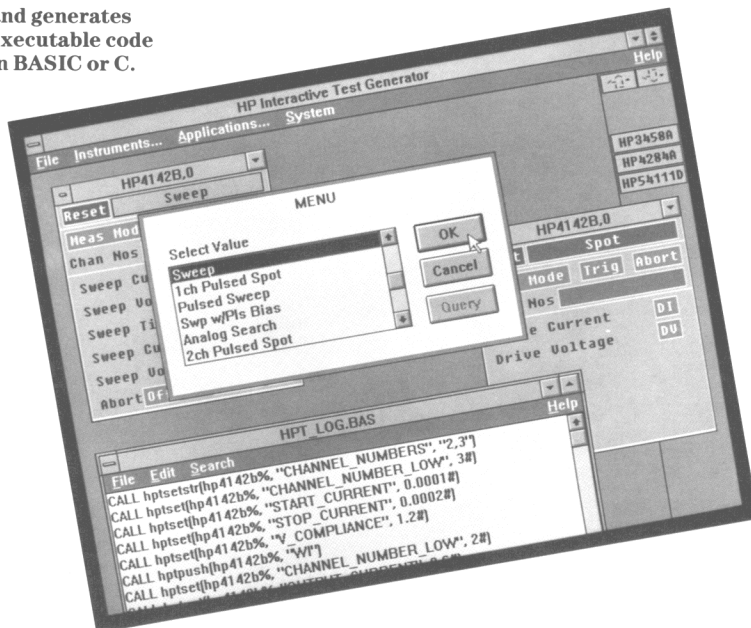

ITG instrument control panels are now compatible with the powerful Visual Engineering Environment (HP VEE). HP VEE further increases your productivity by graphically linking instrument panels, analysis, and presentation objects into solutions using advanced icon-based software.

ITG/UX generates HP BASIC code under HP BASIC/UX. ITG/DOS operates under Microsoft Windows 3.0 and generated Microsoft C, Quick C, or QuickBASIC code. HP VEE is a Motif application that runs on HP 9000 HP-UX systems. Each environment supports the HP 4142B.

Applications

Evaluate Multi-channel Devices

Previous parametric testers overly complicated the measurement of multi-channel devices. Users had to interconnect current/voltage sources, nanovoltmeters, and picoammeters. The HP 4142B integrates these features into one instrument, thereby simplify the procedure and reducing test time. A typical configuration includes:

- 1 HP 41420A (2 slots)
Source Monitor Unit
- 4 HP 41421B (4 slots)
Source Monitor Unit
- 1 HP 41424A VS/VMU (1 slot)
- 1 HP 41425A (1 slot)
Analog Feedback Unit

This assortment of modules suits most applications. You can test ECL circuits, multiple MOSFETs, ring oscillators, operational amplifiers, analog/digital switches, and hybrid circuits. For example, stimulating several MOSFETs at once lets you extract ΔL , ΔW , and a host of swept parameters (I_D - I_{DS} , I_D - V_{GS} , G_m - V_{GS} , and V_T vs. Temperature).

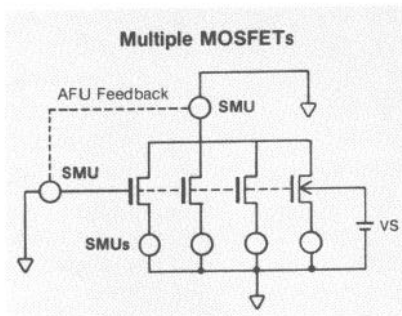

Efficiently test multiple MOSFETs

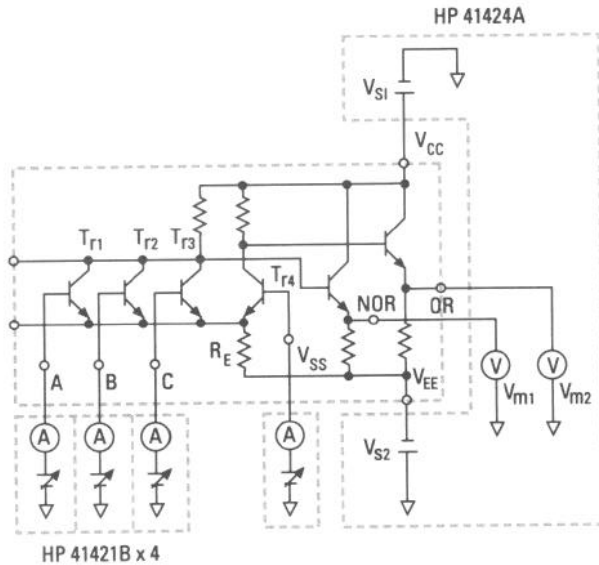

Easily characterize ECL circuits

Characterize High Power and Smart Power Devices

Combine the HP 4142B and HP 16087A switch to automate testing of your devices which require both high power and sub-pA resolution. The ability of the HP 4142B to easily synchronize and combine plug-in modules, allows expanded coverage to 2000V and 20A. The HP 16087A is a 3-input scanner which greatly simplifies your task of configuring HVUs, HCU, or SMUs for single insertion testing.

The HP 4142B also provides a general purpose 16-bit TTL output (open collector) for extended systems functions, such as external relay controls and/or controlling test device internal settings. This insures your ability to exercise your smart power devices fully with a single test setup.

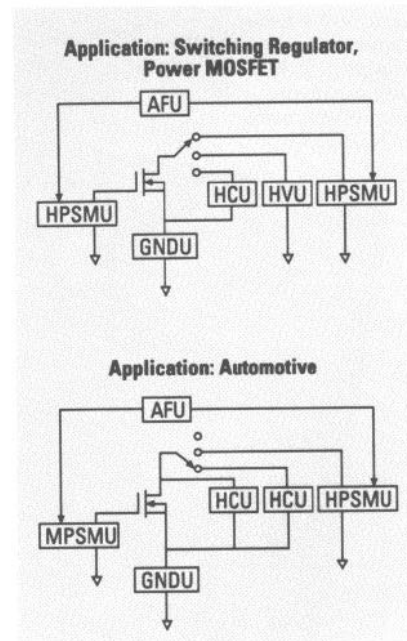

Automate high power testing with the HP 16087A 3-input scanner.

Applications

GaAs Test and Development

The ability to provide DC and RF in both continuous and pulsed modes is important for testing gallium arsenide (GaAs) and other microwave devices. To verify process quality and device performance, you need a versatile DC parameter test instrument which can also act as a bias supply during RF test. Conventional power supplies and voltmeters provide awkward solutions which can damage high frequency devices or produce erroneous results if not carefully used.

The precision DC parametric measurement capability and flexible configuration of the HP 4142B make it ideal for comprehensive test of microwave devices in R&D or production. Its SMU architecture prevents damage due to bias supply glitching or overshoot. Its pulse capability reduces thermal drift error and allows testing of high power devices, even at the wafer level.

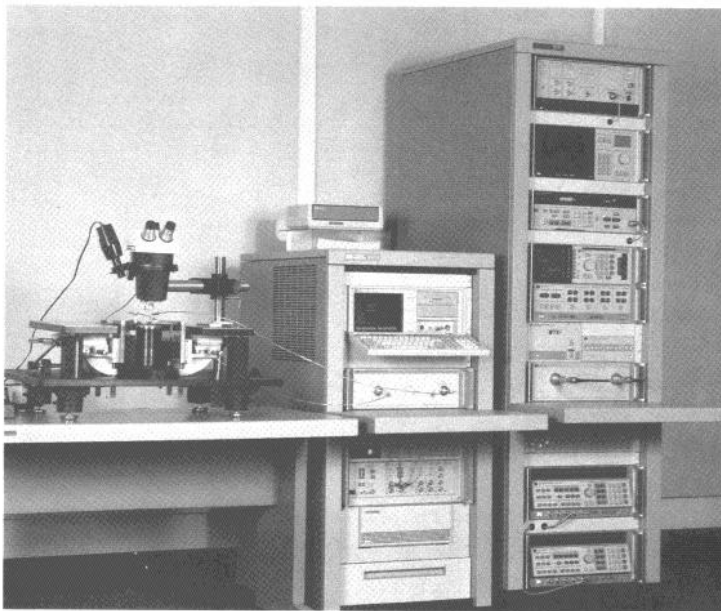

The HP 4142B obtains all DC parameters and provides RF biasing for single connection microwave testing.

Upgrade to a Full Process Monitor System

The HP 4142B was designed for high throughput without sacrificing accuracy or resolution. By adding a capacitance meter, switching matrix, and software, you can upgrade your HP 4142B to the HP 4062C Process Control System. Your HP 4142B software investment is preserved with this migration as well. Use the HP 9000 Series 300 controller, or IBM PC compatible with HP co-processor card to make DC or capacitance measurements which meet your R&D or production test requirements. The HP 4085B switching matrix is specially designed for overhead probing, and guarantees full system accuracy right down to the wafer probing interface.

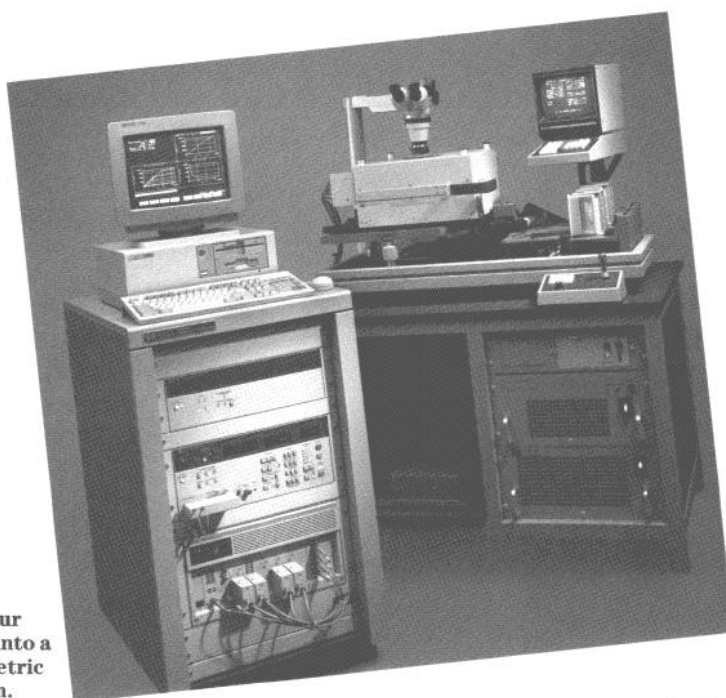

Expand your HP 4142B into a full parametric test system.

Features

Modular Architecture

The HP 4142B provides eight slots for a variety of plug-in measurement units. Reduce startup costs by customizing the HP 4142B for your application. As your needs increase, simply add more units. As you move from benchtop to production, easily migrate your tests by adding a compatible wafer prober, switching matrix, capacitance meter, and system software.

Versatile Source Monitor Units (SMUs)

For general purpose DC or pulsed measurements, use the HP 4142B Source Monitor Units. The equivalent of four instruments, these precision modules force voltage while measuring currents down to 20fA. Or force current and simultaneously monitor voltages down to 40 μ V. The HP 41421B SMU conserves space (1 slot) by limiting ranges to ± 100 V and ± 100 mA. The HP 41420A (2 slots) extends the range to ± 200 V and ± 1 A.

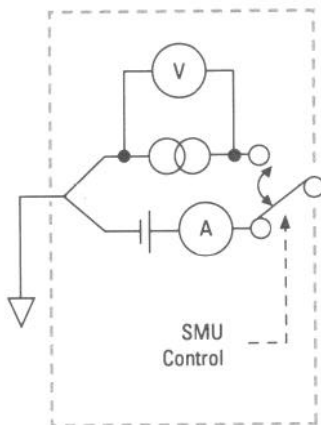

Simplified SMU block diagram

Both SMUs are four-quadrant sources using full active guard and Kelvin connections. The active guard minimizes voltage differentials which add significant noise and cable loss errors when measuring currents below 1pA. The 4-wire Kelvin sensing on the SMUs and built-in Ground Unit (GNDU) assure accuracy right to the device pins, eliminating resistive cable loss errors when measuring low voltages or large currents.

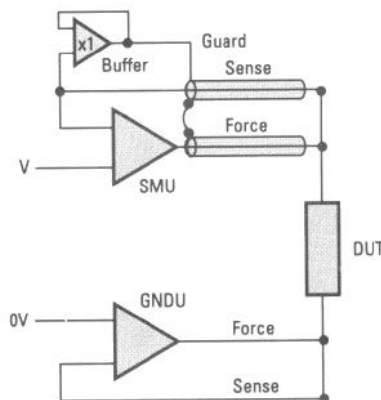

HP 41422A High Current Unit

Use the HP 41422A High Current Unit to make fast 100 μ s pulsed measurements up to ± 10 V and 10A. It is a pulsed source/monitor unit with the same 5-digit basic accuracy of the standard SMUs. A specially low-inductance cable design and built-in ground return let you make low level and high power tests with equal ease.

Synchronized pulse capability has been added to the HCU so that it can be used in tandem with another HCU or the standard SMUs. Prevent thermal drift or damage by using this dual pulse feature to sweep your high power devices.

The force-sense-guard and stable ground reference (GNDU) eliminate system noise and cable errors.

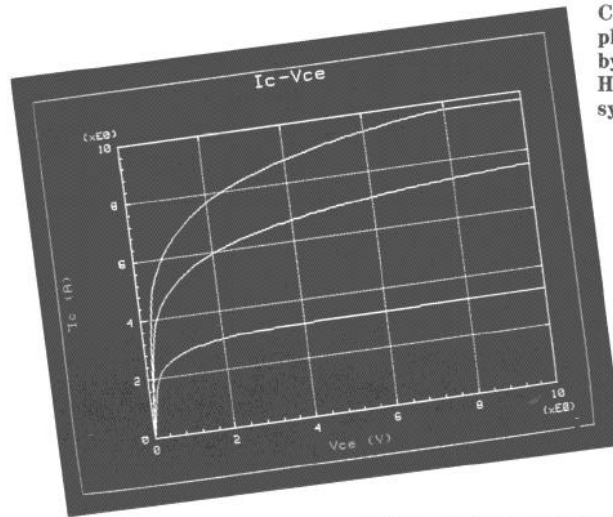

Create high power plots in seconds by pulsing the HCU and SMU synchronously.

Features

HP 41423A High Voltage Unit

Safely and reliably make DC or pulsed measurements to ± 1000 V with the HVU source monitor unit. Its low leakage design allows current measurements down to 2 pA. A special high voltage triaxial cable, connectors, fixture interlock, and a LED status indicator provide hazard protection and convenience while maintaining full system accuracy.

The HVU has the same pulse capability as the standard SMUs, including the unique quasi-pulse mode. Quasi-pulse is an advanced pulse feature allowing a source to monitor its slew rate and abruptly power down when a specific voltage or current compliance condition is met. You can very rapidly determine voltage breakdowns while minimizing the risk of damage due to excessive stress. Or speed up leakage current measurement times by monitoring the current automatically when the voltage reaches a specified stop value.

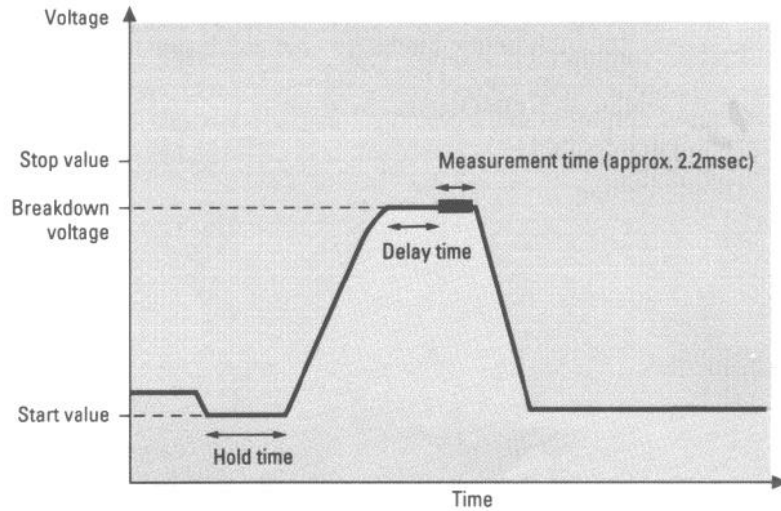

Quickly and safely find breakdown voltages using the smart quasi-pulse mode.

HP 41425A Analog Feedback Unit

To find important parameters that are specified at a given voltage or current, such as V_{th} or h_{FE} , connect the HP 41425A Analog Feedback Unit between two SMUs. The AFU modulates the output voltage of one SMU while monitoring the current or voltage of the second SMU. Target currents and voltages are found with blazing speed (12 msec). The AFU is connected internally, so no external hookup is necessary.

You can perform useful measurements which were previously impractical using lengthy binary searches. For example, quickly monitor V_{th} vs substrate bias or V_{th} vs Temperature. Or use the AFU with a network analyzer to quickly search for bias conditions during characterization of a microwave transistor.

Typical AFU application—Controlling the gate bias of a MOS transistor using the drain current.

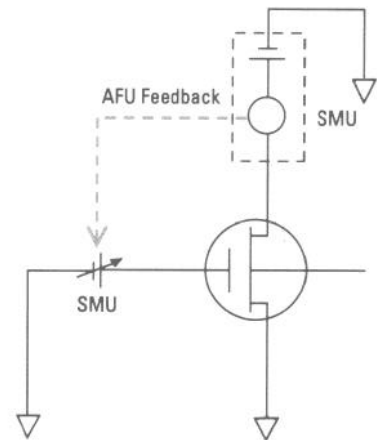











Features

Measurement Modes

The plug-in units may be operated individually or in synchronized modes to perform ten different types of measurements. The table below describes each mode and the plug-in units supporting each mode.

Available units in each Measurement Mode.

| Output Waveform | Measurement Mode | Description | Unit | | | | |
|---|---------------------------------|---|------|-----|-----|----|-----|
| | | | SMU | HCU | HVU | VS | AFU |
|  | Spot | Multiple sources force constant voltages or currents. All outputs may be monitored when the measurement is triggered. | ● | | ● | ● | |
|  | Staircase sweep | One or two sources sweep V or I. Additional sources may force constant V or I. All outputs may be monitored when the measurement is triggered. | ● | | ● | ● | |
|  | 1 channel pulsed spot | One source forces pulsed V or I. Additional sources may force constant V or I. One output may be monitored when the measurement is triggered. | ● | ● | ● | ● | |
|  | Pulsed sweep | One source sweeps pulsed V or I. Additional sources may force constant V or I. One output may be monitored when the measurement is triggered. | ● | ● | ● | ● | |
|  | Staircase sweep with pulse bias | One source sweeps V or I, while another source synchronously forces pulsed V or I. One output may be monitored. | ● | ● | ● | ● | |
|  | Analog search | Searches for a specified current or voltage on one SMU by controlling the voltage output of another SMU. Requires the AFU. | ● | | | | ● |
|  | 2 channel pulsed spot | Two sources force pulsed outputs at the same time. One of the outputs may be monitored when the measurement is triggered. One source must be an HCU. | ● | ● | | | |
|  | Pulsed sweep with pulse bias | Two channels synchronously sweep pulsed V or I. One of the outputs may be monitored when the measurement is triggered. One source must be an HCU. | ● | ● | | | |
|  | Quasi-pulse | One source forces a quasi-pulsed voltage. The pulse is formed by ramping a source until its slew rate abruptly changes. Used for making fast and safe breakdown or leakages tests. One output may be monitored when the pulse is triggered. | ● | | ● | | |
|  | High speed spot | Multiple sources force constant V or I. Only one of the outputs may be monitored. Performed with fewer commands than spot. | ● | | ● | ● | |

Accessories

Improve the reliability of your test results by using accessories that were designed to take full advantage of the HP 4142B's wide measurement range. The HP 16088B test fixture is a 13-channel shielded dark box, with low leakage Kelvin connections. An array of optional plug-in socket modules provide hassle free hookup to most industry standard packaged parts. When ordered with opt 300, the HP 16088B includes a built-in HP 16087A control module (3-input scanner) for accurate and safe switching of a HVU, HCU, or SMU to a single device pin. For your convenience, the HP 16088B is compatible with both triaxial or SMU quadaxial style cables.

HP 16088B Test Fixture and Accessories

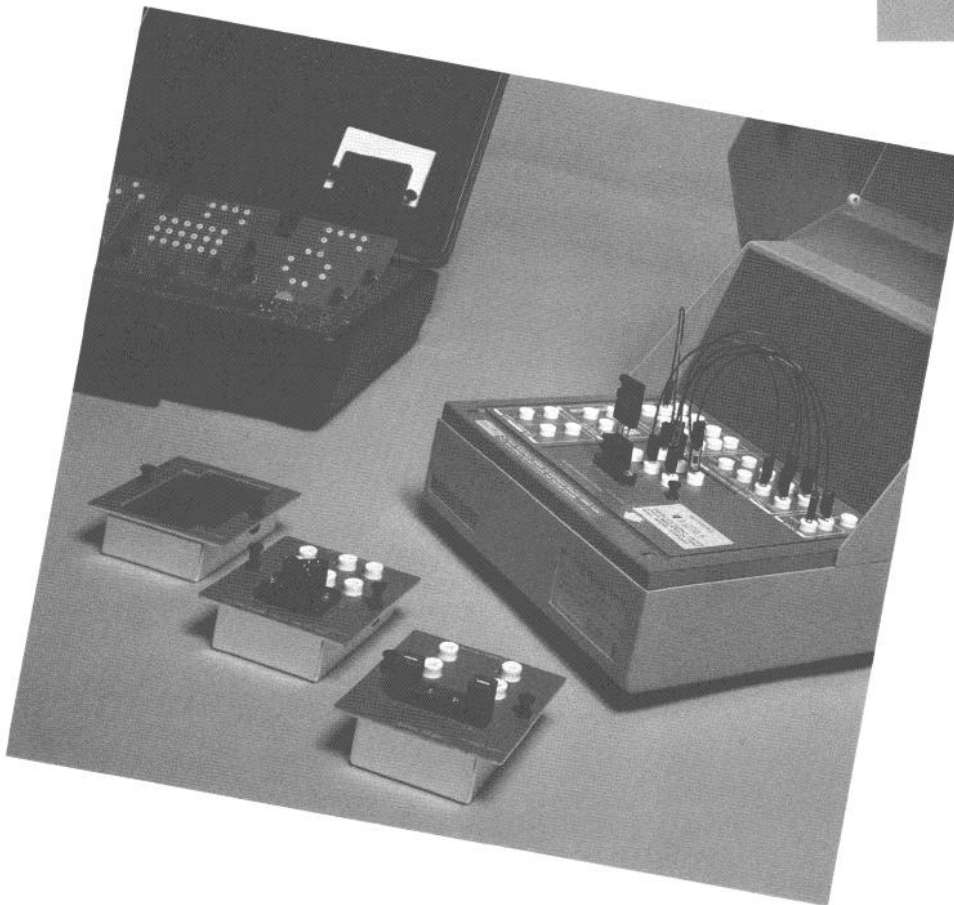

For wafer probing, the HP 16087A control module is provided with its associated on/off status indicator and connector plate. Order additional cables or a variety of connector plates to meet your particular interfacing application.

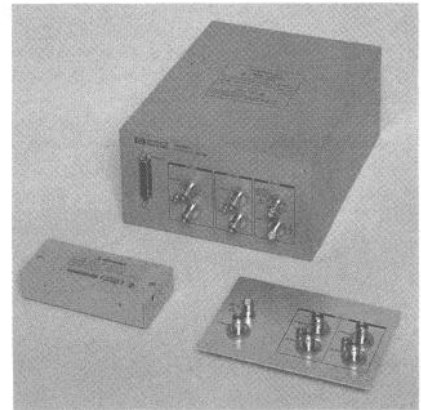

HP 16087A Control Module, On/Off Status Indicator, and Connector Plate.

Specifications

HP 4142B Mainframe

Chassis

8 slots for plug-in measurement units.
No more than one HP 41425A Analog Feedback Unit per mainframe.
Maximum Common to Ground Voltage: $\pm 42V$.

Supported Plug-in Measurement Units

| Model Number | Number of Slots Occupied | Range of Operation* |
|------------------|--------------------------|--|
| HP 41420A HPSMU | 2 | 40 μ V to 200V, 20fA to 1A |
| HP 41421B MPSMU | 1 | 40 μ V to 100V, 20fA to 100mA |
| HP 41422A HCU | 2 | 40 μ V to 10V, 20nA to 10A |
| HP 41423A HVU | 2 | 2mV to 1000V, 2pA to 10mA |
| HP 41424A VS/VMU | 1 | 4 μ V to 40V, 20 μ A to 100mA |
| HP 41425A AFU | 1 | Used with two SMUs to make analog voltage/current searches |

* 2000V max using two HVUs or 20A (pulsed) using two HCUs

Maximum Output Power

The sum of all measurement unit's instantaneous output power (product of Voltage Range and Current Output or Current Compliance) cannot exceed 32W. Each unit can be switched off to consume 0W power when in standby (power save) mode.

| Unit | Instantaneous Output Power |
|------------------|---|
| HP 41420A HPSMU | $V_{range} \times I_0$ (or I_C) ¹ |
| HP 41421B MPSMU | |
| HP 41422A HCU | $10W + 20V \times I_0$ (or I_C) x duty cycle ² |
| HP 41423A HVU | $10W + V_0$ (or V_C) x I_C (or I_0) |
| HP 41424A VS/VMU | 2.2W (20V range) for each VS 0.88W (40V range) for each VS |
| HP 41425A AFU | 0W |
| GNDU SMU | 0W |

V_0 : V output set, V_C : V compliance, I_0 : I output set, I_C : I compliance

²2V range is calculated as 20V for the HP 41420A and HP 41421B

¹Max pulse duty cycle: 1mA-1A range: 10% 10A range: 1%

Ground Unit (GNDU)

The GNDU is part of the HP 4142B mainframe. It is configured as a high current SMU set to 0 Volts. Used as measurement ground.

| | |
|--------------------------|-----------------|
| Connection: | 0 Volt, Kelvin |
| Maximum offset voltage: | $\pm 500\mu V$ |
| Current range: | $\pm 1.6A$ |
| Maximum cable resistance | |
| FORCE terminal: | $\leq 1\Omega$ |
| SENSE terminal: | $\leq 10\Omega$ |
| Maximum capacitive load: | 10 μF |

Control Unit (CTLU)

The control unit provides two functions. It controls the HP 16087A 3-input module selector, and provides a general purpose 16-bit TTL output (open collector) for extended system functions. Intended use of the TTL output is for external relay control and/or setting of test device internal settings.

Module Selector Relay Control Reference Data

| | |
|------------------------|--------|
| Output voltage: | 24V |
| Current limit: | 30mA |
| Typical control speed: | 30msec |

16-Bit Relay Control Reference Data

| | |
|---------------------------|-------------------------------|
| Maximum voltage: | 20V |
| Saturation voltage: | 0.7V (at sink current = 50mA) |
| Pull-up voltage/resistor: | 4.5V/10k Ω |
| Typical control speed: | 10ms |

Memory

The HP 4142B mainframe contains two types of memory which increase test speed. The program memory allows high-speed testing of multiple devices without the need to communicate over the HP-IB interface. The data memory collects and sends spot or swept data efficiently over the HP-IB interface.

Program memory: Stores approx. 2000 program steps, which can be grouped into 99 subroutines.

Data memory: Maximum of 4095 data values (binary)
Maximum of 1023 data values (ASCII)

Interfaces

| | |
|--------------------------|--|
| External trigger input: | TTL level negative logic |
| Minimum pulse width: | 100 μ sec |
| External trigger output: | TTL level negative logic |
| Approx pulse width: | 100 μ sec |
| HP-IB interface: | SH1, AH1, T6, L4, SR1, RL1, PP0, DC1, DT1, C0, E1. |

General Reference

Self-Test

At power-up the HP 4142B checks the operation of its own operational status. The self-test can be performed at any time via HP-IB.

Auto-Calibration

The offset errors in each measurement unit are automatically calibrated every 30 minutes.

Environmental Information

| | |
|------------------------------|--|
| Operating temperature: | 5°C to 40°C |
| Allowable temperature drift: | $\pm 3^\circ C$ (after auto-calibration) |
| Operating humidity: | 5% to 80% RH |
| Storage temperature: | -40°C to 65°C |
| Storage humidity: | $\leq 90\%$ RH at 65°C |
| Operating inclination: | $\pm 20^\circ$ from horizontal |

Power requirements

| | |
|---------------|----------------|
| 100/120/220V: | $\pm 10\%$ |
| 240V: | -10% to +5% |
| Maximum VA: | 750 (48-66 Hz) |

Dimensions

426mm W by 235mm H by 676mm D

Weight (approx.)

| | | | |
|---------------------|------|------------|-----|
| HP 4142B mainframe: | 23kg | HP 41423A: | 3kg |
| HP 41420A: | 3kg | HP 41424A: | 2kg |
| HP 41421B: | 2kg | HP 41425A: | 2kg |
| HP 41422A: | 2kg | | |

Reference Data for HP 4142B

Recommended Computer

Consult the HP 4142B configuration, guide Lit. no 5091-0634E, for computers supported on each of the following three platforms:

- BASIC operating system on HP 9000 Series 300 workstations
- BASIC/UX operating system on HP 9000 Series 300 workstations
- BASIC/MS-DOS operating system on HP Vectra or IBM compatible PCs

Software

Included with the HP 4142B

Parameter Measurement Library: Resistance, MOS, and bipolar transistor algorithm sets

Test Instruction Set: Initialize, Force, Measure, Pulse, Sweep, Graphics, and Data Storage.

Additional software

HP IMA (Interactive Measurement and Analysis) WS, UX, or PC

HP ITG (Interactive Test Generator) WS, UX, or PC

HP IC-CAP (Integrated Circuit Characterization and Analysis Program) UX

Specifications

Typical Measurement Times

HP 9000 Series 332 computer.
ASCII data transfer time is included.

HP 41420A/HP 41421B SMU
(20V/100mA range, spot measurement)

Force I or V: 3.5msec
Measure I or V: 4.0msec

HP 41425A AFU
 V_T at $I_D = 1\mu\text{A}$: 12msec

HP-IB Data Transfer Rate
ASCII format: 1300 μsec /point
Binary format: 450 μsec /point

Measurement Accuracy

Is specified at front panel connector terminals, referenced to SMU common, under the following conditions:

- 23 °C \pm 5 °C
- 40 minute warm-up period
- Auto Calibration enabled
- Kelvin connection

HP 41420A High Power Source/Monitor Unit

The HP 41420A HPSMU occupies two slots in the HP 4142B mainframe. It sources voltage and monitors current, or sources current and monitors voltage. Separate FORCE and SENSE terminals enable Kelvin connections (remote sensing).

Output/Measurement Range, Resolution and Accuracy.

| Voltage Range | Set. Resolution | Meas. Resolution | Accuracy | Maximum Current |
|-------------------|-------------------|-------------------|-------------------------------|---|
| $\pm 2\text{V}$ | 100 μV | 40 μV | $\pm (0.05\% + 1\text{mV})$ | $\pm 1\text{A}$ |
| $\pm 20\text{V}$ | 1mV | 400 μV | $\pm (0.05\% + 10\text{mV})$ | $\pm 1\text{A}$ ($ V \leq 14\text{V}$) $\pm 0.7\text{A}$ ($ V > 14\text{V}$) |
| $\pm 40\text{V}$ | 2mV | 800 μV | $\pm (0.05\% + 20\text{mV})$ | $\pm 350\text{mA}$ |
| $\pm 100\text{V}$ | 5mV | 2mV | $\pm (0.05\% + 50\text{mV})$ | $\pm 125\text{mA}$ |
| $\pm 200\text{V}$ | 10mV | 4mV | $\pm (0.05\% + 100\text{mV})$ | $\pm 50\text{mA}$ |

| Current Range | Set. Resolution | Meas. Resolution | Accuracy | Maximum Voltage |
|----------------------|------------------|------------------|---|-------------------|
| $\pm 1\text{nA}$ | 50fA | 20fA | $\pm (1\% + 6\text{pA} + 20\text{fA} \times V_{\text{OUT}})$ | $\pm 200\text{V}$ |
| $\pm 10\text{nA}$ | 500fA | 200fA | $\pm (1\% + 15\text{pA} + 200\text{fA} \times V_{\text{OUT}})$ | |
| $\pm 100\text{nA}$ | 5pA | 2pA | $\pm (0.5\% + 100\text{pA} + 2\text{pA} \times V_{\text{OUT}})$ | |
| $\pm 1\mu\text{A}$ | 50pA | 20pA | $\pm (0.5\% + 1\text{nA} + 20\text{pA} \times V_{\text{OUT}})$ | |
| $\pm 10\mu\text{A}$ | 500pA | 200pA | $\pm (0.2\% + 10\text{nA} + 200\text{pA} \times V_{\text{OUT}})$ | |
| $\pm 100\mu\text{A}$ | 5nA | 2nA | $\pm (0.2\% + 100\text{nA} + 2\text{nA} \times V_{\text{OUT}})$ | |
| $\pm 1\text{mA}$ | 50nA | 20nA | $\pm (0.2\% + 1\mu\text{A} + 20\text{nA} \times V_{\text{OUT}})$ | |
| $\pm 10\text{mA}$ | 500nA | 200nA | $\pm (0.2\% + 10\mu\text{A} + 200\text{nA} \times V_{\text{OUT}})$ | |
| $\pm 100\text{mA}$ | 5 μA | 2 μA | $\pm (0.2\% + 100\mu\text{A} + 2\mu\text{A} \times V_{\text{OUT}})$ | |
| $\pm 1\text{A}$ | 50 μA | 20 μA | $\pm (0.5\% + 1\text{mA} + 20\mu\text{A} \times V_{\text{OUT}})$ | |

Note: V_{OUT} is the SMU output voltage in volts.

Voltage/Current Compliance

The SMU can limit output voltage or current to prevent damage to a device under test.

Compliance voltage and current resolutions are the same as the Setting Resolutions in the table above, however the maximum compliance current resolution is 1pA. The Accuracy specifications, listed in the above table, apply also to the accuracy of compliance settings.

Current Over-range

1nA–100mA range: 15% of range
1A range: 0%

Reference Data for HP 41420A

Maximum capacitive load: 1000pF
Maximum guard capacitance: 900pF
Maximum shield capacitance: 5000pF
Maximum cable resistance
FORCE terminal: 10 Ω (100mA)
0.7 Ω (1A)
SENSE terminal: 10 Ω

Typical voltage source output resistance/current measurement input resistance (non-Kelvin connection): 0.2 Ω

Typical voltage measurement input resistance/current source output resistance: $\geq 10^{12}\Omega$

Guard offset voltage: $\pm 1\text{mV}$

Noise (typical)
(20V range, 10 μA or above)

Voltage source: 0.005% of V range (rms)
Current source: 0.005% of I range (rms)
Voltage monitor: 0.01% of V range (p-p)
Current monitor: 0.05% of I range (p-p)

Output overshoot (typical)
Voltage source: 0.03% of V range
Current source: 0.03% of I range

Typical range switching transient noise
Voltage ranging: 250mV
Current ranging: 10mV

Maximum slew rate: 2V/ μsec

HP 41421B Medium Power Source/Monitor Unit

The HP 41421B MPSMU requires one slot in the HP 4142B mainframe. It sources voltage and monitors current, or sources current and monitors voltage. Separate FORCE and SENSE terminals enable Kelvin connections (remote sensing).

Output/Measurement Range, Resolution and Accuracy.

| Voltage Range | Set. Resolution | Meas. Resolution | Accuracy | Maximum Current |
|-------------------|-------------------|-------------------|------------------------------|--------------------|
| $\pm 2\text{V}$ | 100 μV | 40 μV | $\pm (0.05\% + 1\text{mV})$ | $\pm 100\text{mA}$ |
| $\pm 20\text{V}$ | 1mV | 400 μV | $\pm (0.05\% + 10\text{mV})$ | |
| $\pm 40\text{V}$ | 2mV | 800 μV | $\pm (0.05\% + 20\text{mV})$ | |
| $\pm 100\text{V}$ | 5mV | 2mV | $\pm (0.05\% + 50\text{mV})$ | |

| Current Range | Set. Resolution | Meas. Resolution | Accuracy | Maximum Voltage |
|----------------------|------------------|------------------|---|-------------------|
| $\pm 1\text{nA}$ | 50fA | 20fA | $\pm (1\% + 6\text{pA} + 20\text{fA} \times V_{\text{OUT}})$ | $\pm 100\text{V}$ |
| $\pm 10\text{nA}$ | 500fA | 200fA | $\pm (1\% + 15\text{pA} + 200\text{fA} \times V_{\text{OUT}})$ | |
| $\pm 100\text{nA}$ | 5pA | 2pA | $\pm (0.5\% + 100\text{pA} + 2\text{pA} \times V_{\text{OUT}})$ | |
| $\pm 1\mu\text{A}$ | 50pA | 20pA | $\pm (0.5\% + 1\text{nA} + 20\text{pA} \times V_{\text{OUT}})$ | |
| $\pm 10\mu\text{A}$ | 500pA | 200pA | $\pm (0.2\% + 10\text{nA} + 200\text{pA} \times V_{\text{OUT}})$ | |
| $\pm 100\mu\text{A}$ | 5nA | 2nA | $\pm (0.2\% + 100\text{nA} + 2\text{nA} \times V_{\text{OUT}})$ | |
| $\pm 1\text{mA}$ | 50nA | 20nA | $\pm (0.2\% + 1\mu\text{A} + 20\text{nA} \times V_{\text{OUT}})$ | |
| $\pm 10\text{mA}$ | 500nA | 200nA | $\pm (0.2\% + 10\mu\text{A} + 200\text{nA} \times V_{\text{OUT}})$ | |
| $\pm 100\text{mA}$ | 5 μA | 2 μA | $\pm (0.2\% + 100\mu\text{A} + 2\mu\text{A} \times V_{\text{OUT}})$ | |
| $\pm 1\text{A}$ | 50 μA | 20 μA | $\pm (0.5\% + 1\text{mA} + 20\mu\text{A} \times V_{\text{OUT}})$ | |

Note: V_{OUT} is the SMU output voltage in volts.

Specifications

Voltage/Current Compliance

Same as the HP 41420A HPSMU

Current Over-range

1nA–10mA range: 15% of range
100mA range: 0%

Reference Data for HP 41421B

Same as the HP 41420A HPSMU

HP 41422A High Current Source/Monitor Unit

The HP 41422A HCU occupies two slots and operates in pulse mode only. It sources voltage and monitors current, or sources current and monitors voltage. Separate FORCE and SENSE terminals enable Kelvin connections (remote sensing).

Output/Measurement Range, Resolution and Accuracy. (PULSE ONLY)

| Voltage Range | Set. Resolution | Meas. Resolution | Accuracy | Maximum Current |
|-----------------------|-----------------|------------------|------------------|---------------------|
| ± 2V | 200μV | 40μV | ± (0.5% + 10mV) | ± 10A (Unipolar) |
| ± 20V (± 10V max.) | 2mV | 400μV | ± (0.5% + 100mV) | |

| Current Range | Set. Resolution | Meas. Resolution | Accuracy | Maximum Voltage |
|---------------|-----------------|------------------|---|---------------------|
| ± 1mA | 100nA | 20nA | ± (0.5% + 2μA + 100nA × V _{OUT}) | ± 10V (Unipolar) |
| ± 10mA | 1μA | 200nA | ± (0.5% + 20μA + 1μA × V _{OUT}) | |
| ± 100mA | 10μA | 2μA | ± (0.5% + 200μA + 10μA × V _{OUT}) | |
| ± 1A | 100μA | 20μA | ± (1% + 2mA + 100μA × V _{OUT}) | |
| ± 10A | 1mA | 200μA | ± (2% + 20mA + 1mA × V _{OUT}) | |

Note: V_{OUT} is the HCU output voltage in volts.
Pulse is unipolar (voltage and current are the same polarity).
Pulse base value is fixed to 0 volts.

HCU Output and Measurement Range

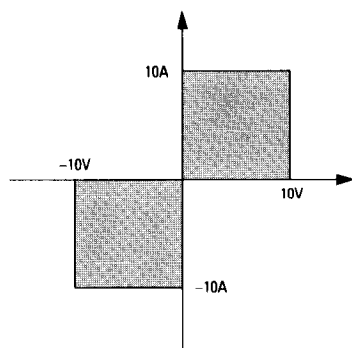

Voltage/Current Compliance

The HCU can limit output voltage or current to prevent damage to a device under test. Compliance voltage and current resolutions are the same as the Setting Resolutions in the table above, however the maximum compliance current resolution is 1μA. The Accuracy specifications, listed in the above table, apply also to the accuracy of compliance settings.

Current Over-range

1mA–1A range: 15% of range
10A range: 0%

Pulse Settings and Accuracy

Single pulse width: 100μsec–1msec
(100μs resolution)
Dual pulse width: 100μsec–800μsec
(100μs resolution)
Maximum pulse duty cycle:
1mA–1A range: 10%
10A range: 1%
Maximum pulse power: 100mJ

Hold time accuracy: 0.5% ± 1msec
Delay time accuracy: 0.5% ± 1msec
Pulse period accuracy: 0.5% ± 100μsec
Pulse width accuracy: 0.5% ± 20μsec

Reference Data for HP 41422A

Maximum capacitive load: 3.5nF
Maximum inductive load: 1μH on 10A range
Maximum cable resistance
FORCE terminal: 150mΩ @ 10V, 10A
SENSE terminal: 10Ω
Maximum cable inductance
FORCE terminal: 200nH max
Noise (typical)
Voltage source: 0.01% of V range (rms)
Current source: 0.1% of I range (rms)
Voltage monitor: 0.02% of V range (p-p)
Current monitor: 0.2% of I range (p-p)
Maximum slew rate: 0.3V/μsec

HP 41423A High Voltage Source/Monitor Unit

The HP 41423A HVU occupies two slots in the HP 4142B mainframe. It sources voltage and monitors current, or sources current and monitors voltage.

Output/Measurement Range, Resolution and Accuracy.

| Voltage Range | Set. Resolution | Meas. Resolution | Accuracy | Maximum Current |
|---------------|-----------------|------------------|-----------------|----------------------|
| ± 100V | 10mV | 2mV | ± (0.5% + 0.5V) | ± 10mA (Unipolar) |
| ± 200V | 20mV | 4mV | ± (0.5% + 1V) | |
| ± 500V | 50mV | 10mV | ± (0.5% + 2.5V) | |
| ± 1000V | 100mV | 20mV | ± (0.5% + 5V) | |

| Current Range | Set. Resolution | Meas. Resolution | Accuracy | Maximum Voltage |
|---------------|-----------------|------------------|----------------|-----------------------|
| ± 100nA | 50pA | 2pA | ± (1% + 1nA) | ± 1000V (Unipolar) |
| ± 1μA | 500pA | 20pA | ± (1% + 10nA) | |
| ± 10μA | 5nA | 200pA | ± (1% + 100nA) | |
| ± 100μA | 50nA | 2nA | ± (1% + 1μA) | |
| ± 1mA | 500nA | 20nA | ± (1% + 10μA) | |
| ± 10mA | 5μA | 200nA | ± (1% + 100μA) | |

Note: Unipolar output means non-zero crossing.
In pulse mode the output may be offset with a base value.

HVU Output and Measurement Range

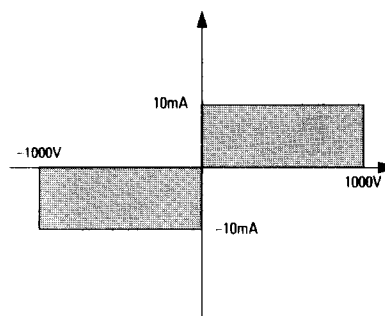

Voltage/Current Compliance

The HVU can limit output voltage or current to prevent damage to a device under test.

Compliance voltage and current resolutions are the same as the Setting Resolutions in the table above, however the maximum compliance current resolution is 2pA. The Accuracy specifications, listed in the above table, apply also to the accuracy of compliance settings.

Specifications

Reference Data for HP 41423A

| | |
|-----------------------------|------------------------|
| Maximum capacitive load: | 1000pF |
| Maximum guard capacitance: | 300pF |
| Maximum shield capacitance: | 800pF |
| Typical output resistance: | 0.2Ω |
| Guard offset voltage: | ± 1mV |
| Noise (typical) | |
| Voltage source: | 0.01% of V range (rms) |
| Current source: | 0.1% of I range (rms) |
| Voltage monitor: | 0.02% of V range (p-p) |
| Current monitor: | 1% of I range (p-p) |
| Change polarity time: | 100msec |
| Channel off/on time: | 100msec |
| Maximum slew rate: | 12V/msec |

HP 41424A Voltage Source/Voltage Monitor Unit

The HP 41424A VS/VMU provides two voltage monitors and two voltage supplies with built-in ammeters. The voltage monitors can be connected in a differential measurement configuration for improved resolution. This module occupies a single slot.

Voltage Source Output/Measurement Range, Resolution and Accuracy.

| Voltage Range | Set Resolution | Accuracy | Maximum Current |
|---------------|----------------|-----------------|-----------------|
| ± 20V | 1mV | ± (0.1% + 10mV) | 100mA |
| ± 40V | 2mV | ± (0.1% + 20mV) | 20mA |

| Current Range | Meas. Resolution | Accuracy |
|---------------|------------------|----------------|
| ± 20mA | 20μA | ± (3% + 200μA) |
| ± 100mA | 100μA | ± (3% + 1mA) |

Voltage Monitor Range, Resolution and Accuracy

| Voltage Range | Meas. Resolution | Accuracy |
|---------------|------------------|------------------|
| ± 2V | 40μV | ± (0.05% + 1mV) |
| ± 20V | 400μV | ± (0.05% + 10mV) |
| ± 40V | 800μV | ± (0.05% + 20mV) |

Differential Voltage Monitor Range, Resolution and Accuracy

| Voltage Range | Meas. Resolution | Accuracy | Max. Common Voltage |
|---------------|------------------|---|---------------------|
| ± 0.2V | 4μV | ± (0.2% + 0.4mV + 2.5μV × V _{IN}) | |
| ± 2V | 40μV | ± (0.2% + 2mV + 25μV × V _{IN}) | ± 40V |

Note: V_{IN} is the VM input voltage (common mode) in volts.

Voltage/Current Compliance

The VS has a current limiter. The limiter value is automatically determined by the output voltage range. If the output range is 20V, the current limit is 100mA. If the output range is 40V, the current limit is 20mA.

Reference Data for HP 41424A

| | |
|-------------------------------|-------------------------|
| VS typical output resistance: | 0.2Ω |
| VS maximum capacitive load: | 10μF |
| VS maximum slew rate: | 0.2V/μsec |
| VS current limit accuracy: | - 0%, + 10% |
| VS typical output noise: | 0.005% of V range (rms) |

| | |
|------------------------------------|------------------------|
| VM typical input resistance: | ≥ 100MΩ |
| VM maximum leakage current (@ 0V): | 2nA |
| VM typical noise level at input: | 0.01% of V range (p-p) |

| | |
|---|------------------------|
| DVM typical differential measurement noise: | 0.02% of V range (p-p) |
|---|------------------------|

HP 41425A Analog Feedback Unit

The HP 41425A AFU searches for a target current or voltage on one SMU by controlling (sweeping) the output voltage of another SMU. It requires one slot and two SMUs. Only one AFU can be used per HP 4142B mainframe. SMUs may be either the HP 41420A HPSMU or HP 41421B MPSMU. The analog search capability of the AFU reduces the time required for measurements like h_{FE} or V_{th} which would otherwise require a more lengthy binary search technique.

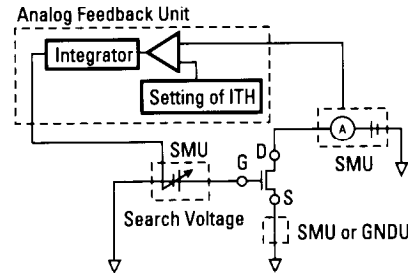

Reference Data for HP 41425A

Monitor Specifications

| | |
|-------------------------|--|
| Range and resolution: | Same as SMU's. |
| Setting accuracy: | SMU's accuracy + 0.1% of value + 0.1% of range. |
| Monitor accuracy: | Same as SMU's. |
| Overrange: | 0% |
| Maximum target voltage: | 180V (HP 41420A HPSMU) 90V (HP 41421B MPSMU) 900mA (HP 41420A HPSMU) 90mA (HP 41421B MPSMU) |
| Maximum current: | |

Search Specifications

| | |
|-------------------------|--|
| Voltage ranges: | 2V, 20V, 40V, 100V, or 200V (HP 41420A only) |
| Slew rates: | 0.5mV/ms to 1000V/ms in decade steps |
| Slew rate resolution: | 1/100 of slew rate range |
| Slew rate accuracy: | 35% of setting + 5% of range |
| Start voltage accuracy: | 0.5% of setting + 0.5% of voltage range |
| Stop voltage accuracy: | 3% of voltage range |
| Ramp stop delay time: | 5μsec (typically) |

HP 16087A Module Selector

The HP 16087A module selector is a 3-input scanner which allows remote control of the connection of an SMU, HCU, or HVU to a single DUT pin. Only one module selector per HP 4142B mainframe is allowed. It may be used by itself or as a built-in option of the 16088B test fixture.

Input Channels

| Channel Type | Number of Channels | Connection |
|------------------------|--------------------|------------|
| SMU (HP 41420A/41421B) | 1 | Kelvin |
| HCU (HP 41422A) | 1 | Kelvin |
| HVU (HP 41423A) | 1 | Non-Kelvin |

Allowable Voltage and Current

| Channel | Max Voltage | Max Current |
|---------|-------------|-------------|
| SMU | 200V | 1A |
| HCU | 10V | 10A |
| HVU | 1000V | 10mA |

Specifications

SMU Channel Reference Data

| | |
|---------------------------------|-------------|
| Maximum leakage current | |
| FORCE (or SENSE) to COM: | 15pA @ 200V |
| Maximum stray capacitance | |
| FORCE (or SENSE) to COM: | 15pF |
| FORCE (or SENSE) to other SMU: | 3pF |
| Maximum guard capacitance | |
| FORCE (or SENSE) to guard: | 60pF |
| Typical residual resistance | |
| FORCE: | 200mΩ |
| Minimum channel off resistance: | 100GΩ |

HCU Channel Reference Data

| | |
|---------------------------------|-----------|
| Maximum leakage current | |
| Hi FORCE to Lo FORCE: | 1nA @ 10V |
| Hi SENSE to Lo SENSE: | 1nA @ 10V |
| Maximum stray capacitance | |
| Hi FORCE to Lo FORCE: | 400pF |
| Hi SENSE to Lo SENSE: | 200pF |
| Typical residual resistance | |
| FORCE (Hi + Lo) | 95mΩ |
| Minimum channel off resistance: | 100GΩ |

HVU Channel Reference Data

| | |
|---------------------------------|-------------|
| Maximum leakage current | |
| FORCE to COM: | 15pA @ 200V |
| Maximum stray capacitance | |
| FORCE to COM: | 15pF |
| FORCE to other SMU: | 3pF |
| Maximum guard capacitance | |
| FORCE to guard: | 30pF |
| Typical residual resistance: | 400mΩ |
| Minimum channel off resistance: | 100GΩ |

HP 16088B Test Fixture

The HP 16088B is a 13-channel fixture designed to test packaged parts over the entire measurement range of the HP 4142B. Option 300 adds a built-in HP 16087A module selector.

Input Channels

| Channel Type | Number of Channels | Connection |
|------------------------|--------------------|------------------------|
| SMU (HP 41420A/41421B) | 4 | Kelvin (8; Non-Kelvin) |
| HCU (HP 41422A) | 2 | Kelvin |
| HVU (HP 41423A) | 2 | Non-Kelvin |
| VS (HP 41424A) | 2 | Non-Kelvin |
| VMU (HP 41424A) | 2 | Non-Kelvin |
| GNDU | 1 | Kelvin |

Allowable Voltage and Current

| Channel | Max Voltage | Max Current |
|---------|-------------|-------------|
| SMU | 200V | 1A |
| HCU | 10V | 10A |
| HVU | 1000V | 10mA |
| VS | 40V | 100mA |
| VMU | 40V | — |
| GNDU | — | 1.6A |

SMU Channel Reference Data

| | |
|--------------------------------|------------------------------|
| Maximum leakage current | |
| FORCE (or SENSE) to COM: | 10pA @ 200V |
| Maximum stray capacitance | |
| FORCE (or SENSE) to COM: | 15pF |
| FORCE (or SENSE) to other SMU: | 3pF |
| Maximum guard capacitance | |
| FORCE (or SENSE) to guard: | 70pF |
| Typical residual resistance | |
| FORCE: | 60mΩ (300mΩ with opt 300) |

HCU Channel Reference Data

| | |
|-----------------------------|------------------------------|
| Maximum leakage current | |
| Hi FORCE to Lo FORCE: | 1nA @ 10V |
| Hi SENSE to Lo SENSE: | 1nA @ 10V |
| Maximum stray capacitance | |
| Hi FORCE to Lo FORCE: | 300pF |
| Hi SENSE to Lo SENSE: | 100pF |
| Typical residual resistance | |
| FORCE (Hi + Lo): | 70mΩ (105mΩ with opt 300) |

HVU Channel Reference Data

| | |
|------------------------------|-------------------------------|
| Maximum leakage current | |
| FORCE to COM: | 10pA @ 200V |
| Maximum stray capacitance | |
| FORCE to COM: | 15pF |
| FORCE to other SMU: | 3pF |
| Maximum guard capacitance | |
| FORCE to guard: | 40pF (60pF with opt 300) |
| Typical residual resistance: | 300mΩ (500mΩ with opt 300) |

VS/VMU Channel Reference Data

| | |
|------------------------------|------|
| Typical residual resistance: | 70mΩ |
|------------------------------|------|

GNDU Channel reference Data

| | |
|-----------------------------|------|
| Typical residual resistance | |
| FORCE or SENSE: | 40mΩ |

HP 16276B/16277B/16278B

Interactive Measurement and Analysis (IMA) Software

The HP IMA software turns the HP 4142B into a full feature parameter analyzer. Software compatibility is maintained to allow HP 4145B test programs to run on the HP 4142B.

Computers operating on three platforms are supported.

HP 16276B IMA/WS

BASIC operating system on HP 9000 Series 300 workstations

HP 16277B IMA/UX

BASIC/UX operating system on HP 9000 Series 300 workstations

HP 16278B IMA/PC

BASIC/MS-DOS operating system on HP Vectra or IBM AT compatible PCs. Requires an HP measurement coprocessor card with at least 4M bytes of memory.

Consult the HP 4142B configuration guide, Literature number 5091-0634E, for details of supported controllers, peripherals, and operating system software revisions.

Basic Functions

- Sets the HP 4142B measurement parameters
- Measurement control
- Arithmetic calculations
- Displays measurement and calculation results
- Graphical analysis
- Printer and plotter hard copy support
- HP BASIC programming environment for automatic measurement and analysis
- Stores and recalls measurement setups and measurement data
- Performs calibration of the HP 4142B

Number of HP 4142B mainframes supported: 1

Number of total HP 4142B units supported: 8 (16 VS/VMU channels)

HP 4142B units supported

HP 41420A High Power Source/Monitor Unit (HPSMU)
 HP 41421B Medium Power Source/Monitor Unit (MPSMU)
 HP 41422A High Current Unit (HCU)
 HP 41423A High Voltage Unit (HVU)
 HP 41424A V Source/V Monitor Unit (VS/VMU)

Specifications

HP 16087A Control Unit (3-input scanner and 16-bit TTL output)
HP 4142B Ground Unit (GNDU)

The HP 41425A (AFU) is not supported.

Measurement Control

VAR1 Sweep

The main sweep. Voltage or current sourcing is controllable over the full range of each supported HP 4142B unit.

| | |
|----------------------------|---|
| Max number of steps: | 1001 |
| Max number of data points: | 4004, 8008 including VAR1' |
| Sweep modes: | Linear or logarithmic Single or double staircase |
| Sweep parameters: | START, STEP, No. of STEPS |
| Hold time: | 0 to 655.35 seconds with 10ms resolution |
| Delay time: | 0 to 65.535 seconds with 1ms resolution |

VAR1' Sweep

Staircase sweep of a second unit which can be slaved to the first. The sweep is made with a user specified fixed ratio and offset value.

VAR1' output is calculated as:
$$\text{VAR1}'(\text{Start}) = a \times \text{VAR1}(\text{Start}) + b$$
$$\text{VAR1}'(\text{Stop}) = a \times \text{VAR1}(\text{Stop}) + b$$
where a is the user-specified ratio and b is the user specified offset value.

VAR2 Sweep

A subordinate linear staircase or pulsed sweep. The VAR2 unit output is incremented one STEP each time the VAR1 units completes one sweep.

Sweep parameters: START, STEP, No. of STEPS
Max number of steps: 32

Pulse modes supported*

| | |
|-----------------|--|
| Single channel: | Measurement limited to one channel. |
| Dual channel: | Two channels can be synchronously pulse. One channel must be an HCU. Measurement limited to one channel. |
| quasi-pulse: | SMU or HVU channel can be ramped until its slew rate abruptly changes. Useful for making quick and safe breakdown or leakage measurements. |

*Pulse is not selectable when VAR1' is set.

Time Domain

Time domain is selectable when VAR1 is not set. VAR1 sweep is replaced by time sweep.

| | |
|------------|---|
| Wait Time: | 0 to 100 seconds with 50ms resolution (Initial wait time or wait time after VAR2 step) |
| Interval: | 50ms to 100 seconds with 50ms resolution (Interval between measurements) |

Display Modes

| | |
|-----------|---|
| Graphics: | Two axes (X-Y1) or three axes (X-Y1,Y2) plot of source, measurement, time, or USER FUNCTION calculations. |
| List: | Used in conjunction with VAR1 or TIME sweep. Up to six measurement parameters and USER FUNCTION results can be displayed for each step of VAR1. |

Arithmetic and Analysis Functions

Arithmetic Functions

Arithmetic expressions can be used in USER FUNCTIONS and user DISPLAY functions. Each expression can contain a maximum of 80 characters.

User Functions

Up to four USER FUNCTIONS can be defined as arithmetic expressions. USER FUNCTIONS are executed during the measurement and the results displayed with measurement results.

Display Functions

Up to two user DISPLAY FUNCTIONS can be defined as arithmetic expressions. These functions are executed in conjunction with the Marker, Cursor, or line operations to get direct output of parameters such as V_T , GM_{MAX} , R_{DS} , etc.

The following graphic analysis parameters may be used in the DISPLAY FUNCTIONS:

- Marker position
- Cursor position
- Line gradient
- Line intersect to axis
- Intersect of two lines
- Regression coefficient of REGRESSION function

Arithmetic Operators

USER and DISPLAY functions may use the following operators:

+ , - , × , / , SQRT(square root), EXP(Napierian constant), LOG (natural log), LGT (common log), ^ (exponentiation), ABS(absolute value), SGN(sign), DELTA (differential calculation), FRACT(fractional), Trigonometric functions (SIN,COS,TAN,ASN,ACS,ATN), and E (scientific notation).

Graphical Analysis Functions

Marker functions

| | |
|----------------|--|
| Interpolation: | × 10 resolution between measurement data points |
| →min or →max: | Moves marker to minimum or maximum data point |
| Direct: | Finds closest data point to user specified value |
| Mouse control: | Finds closest data point to user mouse click |

Cursor functions

| | |
|----------------|---|
| Cursor→Marker: | Moves cursor to the marker position |
| Mouse control: | Cursor follows point where mouse is clicked |

Line functions

| | |
|-------------|---|
| Regression: | Draws a line calculated by the least squares fit method around the marker. Linear scale only. |
| Tangent: | Draws a tangent line to a curve at the marker. |
| Line: | Draws a line between the marker and cursor. |

Scaling functions

| | |
|--------|--|
| Auto: | Graphics automatically resized for optimum display of measurement results. |
| Move: | Reposition the display with cursor at center. |
| Zoom: | Draw a box in the graphics area and expand the box to full scale. May be repeated. |
| Reset: | Resets and moves graphics to original state. |

Buffer functions

| | |
|--------------|--|
| Buffer 1: | Buffer 1 is the working graphics buffer. Analysis is done here. |
| Buffers 2-4: | Stores three additional sets of graphs. |
| Recall: | Allows overlaying of buffer contents for comparison of similar measurements. |
| Exchange: | Exchanges contents between buffer 1 and buffer 2,3, or 4. |

HP 4145B Data Compatibility

The measurement setup and data taken by the HP 4145B is fully compatible with the HP IMA software (except for files containing schmoos, or matrix display, and the ASP file).

Analysis Instruction Set (AIS)

Over 40 subprograms are provided so that all of the capabilities of HP IMA interactive mode may be automated for hands-off data gathering and analysis. AIS subprograms are linked to the HP BASIC programming environment. This allows other instrument control or user interface code to be added for complete turnkey test solutions.

Ordering Information



For complete ordering information, please see the HP 4142B Modular DC Source/Monitor configuration guide (HP literature number 5091-0634E). It suggests application specific ordering examples, including recommended controllers, optional software, cabling, connectors, fixtures, other accessories and support services.

HP 4142B Modular DC Source/Monitor

Ground Unit

Safety Interlock

8 slots for plug-in measurement modules

Mainframe Options

Opt. 050 50Hz Line Frequency

Opt. 060 60Hz Line Frequency

Opt. 100 100/120V Line Voltage

Opt. 220 220/240V Line Voltage

Opt. 300 Control unit*

Measurement Module Options

Opt. 400 HP 41420A HPSMU:200V,1A (2 slots)

Opt. 410 HP 41421B MPSMU:100V,100mA (1 slot)

Opt. 420 HP 41422A HCU:10V,10A (2 slots)

Opt. 430 HP 41423A HVU:1000V,10mA (2 slots)

Opt. 440 HP 41424A VS/VMU:40V,100mA (1 slot)

Opt. 450 HP 41425A AFU (1 slot)

*Required with HP 16087A and HP 16088B opt 300.

Accessories

HP 16058A Test Fixture (Non-Kelvin SMU, VS/VMU)

Includes set of 4 triax cables (1.5m)

Opt. 001 Adds HP 4142B system cable

HP 16087A Module Selector (supports SMU, HCU, HVU)

(Includes connector plate and on/off status indicator)

HP 16088B Test Fixture (Kelvin, supports all HP 4142B plug-in units)

Opt. 010 Socket module set for power devices

Opt. 020 Socket module set for small signal devices

Opt. 030 Universal socket module for custom devices

Opt. 300 Adds module selector (mounted inside fixture)

HP 4142B Application Notes

- AN 356 High Speed DC Characterization of Semiconductor Devices from Sub pA to 1A
- AN 356-1 Techniques and Applications for High Throughput and Stable Characterization
- AN 383-1 Simplification of DC Characterization and Analysis of Semiconductor Devices (HP IMA measurement examples)
- AN 383-2 Automation of DC Characterization and Analysis of Semiconductor Devices (HP IMA programming examples)
- AN 1205 Efficient Microwave Bias and Test Using the HP 4142B Modular DC Source/Monitor

HP 4142B Product Notes

- PN 4142B-1 DC Characterization of Power Devices; Practical Applications Using the HP 4142B Modular DC Source/Monitor

For more information, call your local HP sales office listed in your telephone directory or an HP regional office listed below for the location of your nearest sales office.

United States:

Hewlett-Packard Company
4 Choke Cherry Road
Rockville, MD 20850
(301) 670-4300

Hewlett-Packard Company
5201 Tollview Drive
Rolling Meadows, IL 60008
(708) 255-9800

Hewlett-Packard Company
5161 Lankershim Blvd.
No. Hollywood, CA 91601
(818) 505-5600

Hewlett-Packard Company
2015 South Park Place
Atlanta, GA 30339
(404) 955-1500

Canada:

Hewlett-Packard Ltd.
6877 Goreway Drive
Mississauga, Ontario L4V 1M8
(416) 678-9430

Japan:

Yokogawa-Hewlett-Packard Ltd.
15-7, Nishi Shinjuku 4 Chome
Shinjuku-ku
Tokyo 160, Japan
(03) 5371-1351

Latin America:

Hewlett-Packard
Latin American Region Headquarters
Monte Pelvoux No. 111
Lomas de Chapultepec
11000 Mexico, D.F.
(525) 202-0155

Australia/New Zealand:

Hewlett-Packard Australia Ltd.
31-41 Joseph Street
Blackburn, Victoria 3130
Australia (A.C.N. 004 394 763)
(03) 895-2895

Far East:

Hewlett-Packard Asia Ltd.
22/F Bond Centre
West Tower
89 Queensway
Central, Hong Kong
(852) 848 7777

Europe/Africa/Middle East:

Hewlett-Packard S.A.
Marcom Operations Europe
P.O. Box 529
1180 AM Amstelveen
The Netherlands

© Copyright 1991
Hewlett-Packard Company
Data subject to change
Printed in USA 8/91
5091-1581E